



SIGN & DISPLAY

COLLECTION

Issue 3



EST.  2015

◆ GELATERIA ◆



Welcome

- Market leading designs for every area of promotional signage and display.
- Excellent value for maximum return on investment.
- Used by leading brands and retailers throughout the UK and around the world.
- Many unique features and benefits.
- Huge stocks and fast delivery.
- Majority of products available with no minimum order quantity and no small quantity surcharge.
- Custom colours and sizes available on many lines.
- High quality print service available.



Contents

Page
4 – 77

Outdoor Freestanding/Floor Mounted

- Pavement and Forecourt Signs for displaying short/medium term interchangeable posters – includes Swinger and Sentinel®
- Pavement and Forecourt Signs for medium/longer term printed panels – includes Ecoflex, Swinger and POW!
- Pavement and Forecourt Signs for chalk or chalk pen messaging
- Banner Frames and Bollard Wraps
- Flying Banners – Feather, Teardrop and Rectangle Flags
- Adfresco® Café Barriers
- Parasols
- Signtac® Floor Graphics

Page
78 – 109

Outdoor Wall/Window Mounted

- Dealer/Stockist Signs
- Poster Frames – Snapframes, Slimlok and Hi-Sight
- Illuminated Poster Frames
- Noticeboards and Menu Cases
- Banners and Banner Frames
- Projecting Flange Signs
- Display Flags and Noscrewz window suction bracket
- Information Displays – poster and leaflet combinations
- Chalkboards
- Leaflet Holders
- Stickers, Labels and Window Graphics
- Stand-Off Sign Fixings

Page
110 – 141

Indoor Freestanding/Floor Mounted

- Pole & Rope Barriers
- Easels – for chalkboards and Snapframes
- Poster/Menu Stands
- Showcard Stands/‘Bus Stop’ Signs
- Flying Banners with Base Plate
- Roller Banners and Banner Displays
- Pop-Ups – portable exhibition backdrops
- Promotional Counters
- Modular Pole Display – brochure, poster and banner combinations
- Brochure Stands
- Promotional Floor Mats
- Basket Liners

Page
142 - 159

Indoor
Wall/Window Mounted

- Open/Closed Signs
- Poster Frames – Headliner and Minimus Snapframe
- Illuminated Poster Frames
- Chalkboards
- Sign Nav – wayfinding display/sign system
- Brochure and Leaflet Displays

Page
160 - 165

Indoor
Suspended/Hanging

- Poster/Banner Rails
- Freelight Plus – uses existing in-store lighting
- Magnetic POS Flag Arm/aisle flag holder

Page
166 - 187

Indoor
Counter/Table/Shelf

- Menu and Poster Holders
- Table Talkers
- Leaflet Dispensers
- Chalkboards
- Display Card/Ticket Holders
- Bar Runners and Counter Mats
- Brand Blocks
- Shelf/Display Wobblers
- Ice Cream Holders and Cup Displays

Page
188-199

Print

- Service and Capabilities
- Posters
- Backlit Poster Films – ‘Duratrans’
- Print Product Overview

Page
200-205

**Accessories
& Spares**

Key



FUEL
REWARDS
EVERY 10 VISITS*

SAY HELLO TO REWARDS

GOOD THINGS HAPPEN
WHEN YOU GO+ IT



Download the Shell app today

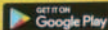

GO WELL



*A star each a maximum spend of £75 on fuel or £2 on products from the shop, excluding lottery tickets, alcohol, beverages, tobacco, phone cards and any other app merchant products. To collect rewards, in full reward for qualifying purchases. See website: Shell Service Station. For more information see: goplus.shell.com

Outdoor Freestanding/Floor Mounted

Experts in this field, we manufacture a market leading range of outdoor portable signs and displays.

Some of these can be large and heavy, so design is critical. Often used in busy pedestrianised areas, in close proximity to parked vehicles or on the kerbside close to passing traffic, safety and reliability is imperative. At the same time they need to be easy to move, in and out of store on a daily basis if required, and poster graphics where applicable must be simple and quick to update. Other than occasional extremes they need to withstand the best and worst of the British weather, year in, year out.

Outdoor freestanding signage, in the retail, service and hospitality sectors in particular, is a powerful tool in the drive to increase market share and sales. With measurable return on investment, top brands and retailers use them widely and consistently to influence consumer decisions and drive footfall. Tactical and multi-functional, they can act as a 'signpost' to your business whilst clearly communicating you are open for business. They can be particularly effective at influencing the impulse shopper.

Swinger (range overview)

Patent No. 2437991 & 2464773
UK Design Registration No. 2071096
EU Design Registration No. 001274229

Why is Swinger the UK's market leading pavement sign?

- Beautifully designed and engineered.
- Low centre of gravity for maximum stability.
- Quick and easy no tools assembly.
- Individually boxed and flat packed with instructions.
- Soft round styling for high pedestrian safety.
- Fully recyclable.



- Optional clip-on Tactical Header (see page 12).
- Patented D-Flex panel hangers allow for easy no tools panel fitting. Flexibility and low friction ensures panel performance.
- Stylish steel frame available in black or white from stock. Custom colour frames available made to order (minimum order quantity 25).
- Choice of aluminium panel or top-opening magnetic poster pocket (shown).
- Solid recycled PVC (shown) or water-fillable HDPE polyethylene base options.



No Tools Assembly

- Simply push base onto frame.

OR



- For Swinger 2 simply lift frame through 90 degrees, straight from the box.



Built-In Wheels

- For ease of movement on heavier Swinger 3000 and 4000 models.



D-Flex Panel Hangers

- Friction-free panel movement.
- Unique design absorbs impact and protects the panel.



Hard-Wearing 'Black' Bases

- Solid recycled PVC on Eco Swinger and Swinger 2.
- Water-fillable polyethylene on Swinger 3000 and 4000 (shown).



Tactical Header

- Clip-on header available on all models.



Powder Coated Steel Frames

- White and black stock options on all models.
- Custom colour frames available made to order (minimum order quantity 25).



Top Opening Poster Pockets

- Easy access poster change.
- Self closing magnetic seals provide excellent weather protection.
- Virtually no risk of poster loss.



The Swinger Family

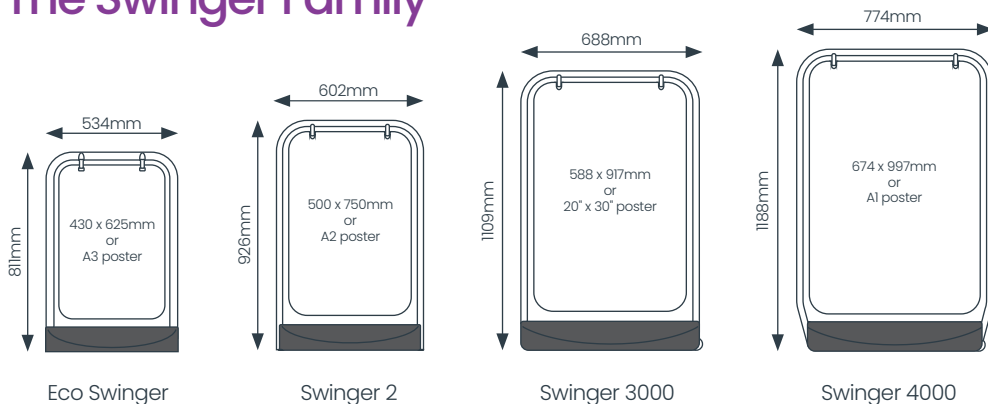

Eco Swinger

The smallest Swinger in our range.

Instruction Video



- Gloss white aluminium panel (430 x 625 x 0.9mm) – ideal for direct to surface print or vinyl graphics.
- Alternative top opening polycarbonate double sided A3 poster pocket with magnetic seals.
- Poster pocket designed with header area for permanent branding – ideal for either direct to surface print or vinyl graphics.
- Custom shaped aluminium panels available made to order (within 430 x 625mm).
- Stylish 32mm round steel tube frame – available in black or white from stock.
- Custom colour frames available made to order (minimum order quantity 25).
- Patented D-Flex panel hangers make panel fitting quick and easy.
- Solid black recycled PVC base provides excellent stability.
- Clip-on Tactical Headers also available, giving extra promotional space at minimal cost (see page 12).



Poster option with easy access top-opening poster pocket.



Effortless no tools assembly.



Fully Recyclable

Display Type	Display Area (mm)	O/A Dimensions (w x h x d mm)	Weight (kg)	Frame Colour	Poster Pocket Colour	Order Code
Aluminium Panel	430 x 625	534 x 811 x 490	11	White	-	SWIECOW
				Black	-	SWIECOB
Poster Pocket	281 x 403 (A3)	534 x 811 x 490	11	White	White	ECOSWPSTW
				Black	Black	ECOSWPSTB



Swinger 2

Our top selling Swinger model.

Patent No. 2549613
Instruction Video



- Gloss white aluminium panel (500 x 750 x 0.9mm) – ideal for direct to surface print or vinyl graphics.
- Alternative top opening polycarbonate double sided A2 poster pocket with magnetic seals.
- Poster pocket designed with header area for permanent branding – ideal for either direct to surface print or vinyl graphics.
- Custom shaped aluminium panels available made to order (within 500 x 750mm).
- Stylish steel tube frame (32mm diameter) – available in black or white from stock.
- Custom colour frames available made to order (minimum order quantity 25).
- Patented D-Flex panel hangers make panel fitting quick and easy.
- Solid black recycled PVC base provides excellent stability.
- Clip-on Tactical Headers also available, giving extra promotional space at minimal cost (see page 12).



Simply lift frame through 90 degrees.



Poster option with easy access top-opening poster pocket.



Fully Recyclable

Display Type	Display Area (mm)	O/A Dimensions (w x h x d mm)	Weight (kg)	Frame Colour	Poster Pocket Colour	Order Code
Aluminium Panel	500 x 750	602 x 926 x 525	13.5	White	-	SWING2ALIW
				Black	-	SWING2ALIB
Poster Pocket	400 x 575 (A2)	602 x 926 x 525	13.5	White	White	SWING2PSTW
				Black	Black	SWING2PSTB



Swinger 3000

A larger Swinger with wheels.



- Gloss white aluminium panel (588 x 917 x 0.9mm) – ideal for direct to surface print or vinyl graphics.
- Alternative top opening polycarbonate double sided 20" x 30" poster pocket with magnetic seals.
- Poster pocket designed with header area for permanent branding - ideal for either direct to surface print or vinyl graphics.
- Custom shaped aluminium panels available made to order (within 588 x 917mm).
- Stylish flat-sided oval steel tube frame (50 x 25mm) – available in black or white from stock.
- Custom colour frames available made to order (minimum order quantity 25).
- Patented D-Flex panel hangers make panel fitting quick and easy.
- Black water-fillable polyethylene base for optimum stability. Custom colours available made to order (minimum order quantity 200).
- Built-in wheels for ease of movement.
- Clip-on Tactical Headers also available, giving extra promotional space at minimal cost (see page 12).



Poster option with easy access top-opening poster pocket.



Effortless no tools assembly.



Fully Recyclable

Display Type	Display Area (mm)	O/A Dimensions (w x h x d mm)	Weight (kg) Empty/Full	Frame Colour	Poster Pocket Colour	Order Code
Aluminium Panel	588 x 917	688 x 1109 x 600	12/31	White	-	H3000BWWA
				Black	-	H3000BBWA
Poster Pocket	488 x 742 (20" x 30")	688 x 1109 x 600	12/31	White	White	SW3KPSTW
				Black	Black	SW3KPSTB



Swinger 4000

Instruction Video



Pack a punch with our largest standard Swinger.



- Gloss white aluminium panel (674 x 997 x 0.9mm) – ideal for direct to surface print or vinyl graphics.
- Alternative top opening polycarbonate double sided A1 poster pocket with magnetic seals.
- Poster pocket designed with header area for permanent branding – ideal for either direct to surface print or vinyl graphics.
- Custom shaped aluminium panels available made to order (within 674 x 997mm).
- Stylish flat-sided oval steel tube frame (50 x 25mm) – available in black or white from stock.
- Custom colour frames available made to order (minimum order quantity 25).
- Patented D-Flex panel hangers make panel fitting quick and easy.
- Black water-fillable polyethylene base for optimum stability. Custom colours available made to order (minimum order quantity 200).
- Built-in wheels for ease of movement.
- Clip-on Tactical Headers also available giving extra promotional space at minimal cost (see page 12).



Effortless no tools assembly. Poster option with easy access top-opening poster pocket.



Fully Recyclable

Display Type	Display Area (mm)	O/A Dimensions (w x h x d mm)	Weight (kg) Empty/Full	Frame Colour	Poster Pocket Colour	Order Code
Aluminium Panel	674 x 997	774 x 1188 x 600	14/32	White	-	SW4KALIW
				Black	-	SW4KALIB
Poster Pocket	574 x 822 (A1)	774 x 1188 x 600	14/32	White	White	SW4KPSTW
				Black	Black	SW4KPSTB



Swinger Tactical Header

Be reactive with our clip-on Swinger header.



- No tools clip-on design. A variant to suit every Swinger model.
- Ideal for short term or dual brand promotions – additional advertising space at a minimal cost.
- 0.9mm rigid gloss white PVC panel ideal for screen/ digital print or vinyl graphics.
- Supplied complete with clips.
- Custom shapes available made to order (minimum order quantity 25).



Fully Recyclable

Type	Size (mm)	Order Code
Eco Swinger	480 x 178	THECO
Swinger 2	542 x 197	THSWING2
Swinger 3000	629 x 231	TH3000
Swinger 4000	716 x 230	TH4000



Custom shaped headers



A-Master

With front opening snapframe.



- Double sided poster display in a wide range of sizes.
- Front opening 32mm profile aluminium snapframes with rounded corners for safety.
- Anti-glare poster cover sheets are UV stable and filter sunlight to protect poster colours.
- Galvanised steel back panels and hinged locking arms for optimum weight and stability.
- Back panel suitable for vinyl application enabling messaging between poster promotions.
- Fold flat design – easy to move and store.
- Stock sizes available in a choice of silver anodised and black powder coated finish.
- Custom sizes available made to order.
- Custom colours available made to order (minimum order quantity 15).
- Optional chalk insert panels available (see page 43).



Rounded corners for style and safety.



Front opening snapframes for quick and easy poster change.



Fully Recyclable

Poster Size	Display Area (mm)	O/A Dimensions (w x h x d mm)	Leg Length (mm)	Weight (kg)	Finish	Order Code
A2	400 x 574	463 x 910 x 700	950	4.5	Silver	ABA2GR(W)
					Black	ABA2BR(W)
20" x 30"	488 x 742	551 x 910 x 700	950	6	Silver	AB23GR(W)
					Black	AB23BR(W)
A1	574 x 821	637 x 1100 x 800	1150	7.5	Silver	ABA1GR(W)
					Black	ABA1BR(W)
A0	821 x 1169	884 x 1400 x 910	1450	16.5	Silver	ABAOGR(W)



A-Master Lite

Lighter in weight, lighter in price.



- Double sided poster display for popular A2 and A1 poster sizes.
- Front opening 25mm profile aluminium snapframes for quick and easy poster change.
- Round corners for pedestrian safety.
- Anti-glare poster cover sheets are UV stable and filter sunlight to protect poster colours.
- Available in hard-wearing satin black or silver anodised finish.
- Smooth galvanized steel back panel suitable for vinyl application, allowing messaging between poster promotions.
- Fold-flat design - easy to move and store.
- Optional chalk insert panels available (see page 43).



25mm profile snapframe.



Rounded corners for safety.



Fully Recyclable

Poster Size	Display Area (mm)	O/A Dimensions (w x h x d mm)	Weight (kg)	Frame Colour	Order Code
A2	400 x 574	450 x 852 x 540	2.75	Silver	ABA2SLITE
			2.9	Black	ABA2BLITE
A1	574 x 821	620 x 1160 x 610	4.55	Silver	ABA1SLITE
			4.7	Black	ABA1BLITE



A-Master Plus

Extended A1 poster display, with extra snapframe header.



Extra snapframe header.



- Double sided A1 poster display in silver anodised finish.
- Snapframe header for 594 x 176mm insert, suitable for vinyl application.
- Front opening 32mm profile aluminium snapframes with rounded corners for safety.
- Galvanised steel back panels and hinged locking arms for optimum weight and stability.
- Anti-glare poster cover sheets are UV stable and filter sunlight to protect poster colours.
- Fold flat design – easy to move and store.
- Recommended for indoor or sheltered outdoor locations.
- Custom colours available made to order (minimum order quantity 200).
- Optional chalk insert panels available (see page 43).

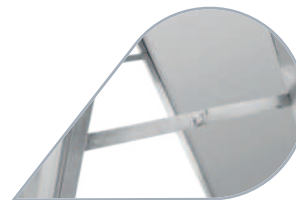

Locking side arms ensure stability.



Front opening snapframes for quick and easy poster change.



Fully Recyclable

Poster Size	Display Area (w x h mm)	Dimensions (mm)	Weight (kg)	Order Code
A1	Poster: 574 x 821 Header: 574 x 156	O/A: 640 x 1112 x 807 Poster: 594 x 841 Header: 594 x 176	10.6	ABA1PLUS



Informer

Double sided display with hidden poster change mechanics.



- Double sided 20" x 30" poster display.
- Anti-glare PET poster covers with magnetic seals offer excellent poster security and weather resistance.
- Printed poster cover sheet border to match frame.
- Poster release: simply push poster cover out of frame via hidden release hole in back panel.
- White polyester powder coated steel frame as standard.
- Custom colour frames available made to order (minimum order quantity 200).
- Folds flat for storage.
- Optional chalk insert panels available (see page 43).



Magnetic sealed poster covers.



Hidden poster cover release hole in back panel.



Hinged side locking arm.

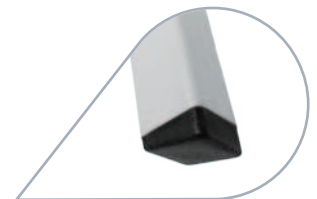

Moulded feet.



Poster Size	Display Area (mm)	O/A Dimensions (w x h x d mm)	Weight (kg)	Order Code
20" x 30"	505 x 759	570 x 890 x 550	12	IN230W(W)

Booster

Attractive poster A-Board with semi-circular header.



- Double sided with additional header area – ideal for vinyl application.
- Anti-glare PET poster covers, with magnetic seals and colour matched borders, provide excellent poster security and weather resistance.
- Poster release: simply push poster cover out of frame via hidden release hole in back panel.
- Steel tube frame (25mm diameter) and steel back panels – available in black or white from stock.
- Seven stock RAL colours available made to order.
- Alternative custom colours available made to order (minimum order quantity 20).



Magnetic poster covers – simply push out via hidden release hole.



Locking side arms ensure stability.

Made to order stock
RAL colours:



Fully Recyclable

Poster Size	Display Area (mm)	O/A Dimensions (w x h x d mm)	Header Area (w x h mm)	Weight (kg)	Colour	Order Code
A2	Poster: 418 x 592 Header: 410 x 230	527 x 1008 x 565	427 x 245	10.5	White	BRA2W(S)
					Black	BRA2BL(S)
20" x 30"	Poster: 506 x 760 Header: 498 x 274	615 x 1237 x 680	515 x 290	14.6	White	BR23W(S)
					Black	BR23BL(S)
A1	Poster: 592 x 839 Header: 590 x 320	701 x 1365 x 747	600 x 332	17.8	White	BRA1W(S)
					Black	BRA1BL(S)



Turn your Booster into a Chalk A-Board with Chalk Insert Panels (for more information see page 43).

Sightmaster 3

Stylish spring mounted snapframe sign with advanced performance features.

- Available in two colour options with advanced style, stability and performance.
- Front opening aluminium snapframes for quick and easy poster change. Opening tool supplied for easy access.
- High strength Aluminium Composite Material back panel has smooth white surfaces for self adhesive vinyl graphics or liquid chalkpen messaging if posters are not in use.
- Unique water-fillable HDPE base with built-in wheels.
- Heavy duty spring mounts ensure stability by allowing panel deflection in the wind.
- Anti-glare poster cover sheets ensure clarity and vibrancy by protecting posters from UV fade.
- Soft round corners for safety.
- Transit trolley available to aid movement when base is full (30" x 40" and A0 sizes only).
- Ideal for forecourts, entrance approaches, car parks, retail outlets and shopping centres.
- Supplied with 2 piece spanner set.



Large base designed for use with our transit trolley (see page 42 for details).



Nylon feet reduce wear and increase stability on uneven surfaces.

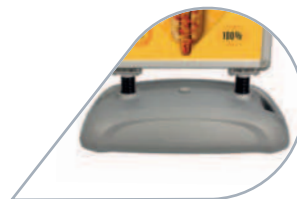

Exclusive design base has optimised water capacity for advanced stability.

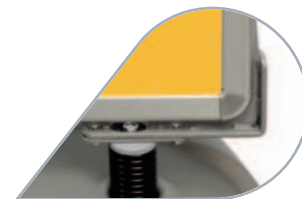

Higher specification corner brackets on 30" x 40" and A0 sizes.



Fully Recyclable



A1



30" x 40"



A0

Instruction Video



Poster Size	Display Area (mm)	O/A Dimensions (w x h x d mm)	Weight (kg) Empty/Full	Colour	Order Code
A1	575 x 822	786 x 1150 x 510	12/48	Silver Frame/Grey Base	SM3AIFRS + SM3SBB
				Black Frame/Black Base	SM3AIFRB + SM3SBB
30" x 40"	744 x 997	956 x 1342 x 609	18.3/81	Silver Frame/Grey Base	SM334FRS + SM3LBG
				Black Frame/Black Base	SM334FRB + SM3LBB
A0	823 x 1173	956 x 1515 x 609	21/83	Silver Frame/Grey Base	SM3A0FRS + SM3LBG
				Black Frame/Black Base	SM3A0FRB + SM3LBB



Type	Size (mm)	Order Code
A1	582 x 200	THSM3A1
30" x 40"	751 x 215	THSM334
A0	829 x 230	THSM3A0

Be reactive with our clip-on Sightmaster 3 Tactical Header.

- Simply clips on to the top of Sightmaster 3 frames (unclip for poster change).
- Ideal for short term or dual brand promotions - additional advertising space at minimal cost.
- 0.9mm rigid gloss white PVC panel ideal for screen/ digital print or vinyl graphics.
- Supplied complete with clips.
- Custom shapes available made to order (minimum order quantity 25).



Fully Recyclable

Spring Sign

A lower cost alternative to Sightmaster 3 - where optimum outdoor performance isn't required, or when price is king!



- Very competitive pricing.
- A1 poster size only in silver or black finish.
- Matches or betters industry standard spring-based poster signs.
- 25% lighter when filled with water than our premium spring-based Sightmaster 3.
- Front opening aluminium snapframes for quick and easy poster change.
- Anti-glare poster cover sheets protect posters from UV fade.
- White aluminium composite (ACM) back panel suitable for permanent self-adhesive vinyl messaging.
- Water-fillable HDPE base with built-in wheels for ease of movement.
- Quick and easy no tools assembly.

Poster Size	Display Area (mm)	O/A Dimensions (w x h x d mm)	Weight (kg) Empty/Full	Colour	Order Code
A1	575 x 822	782 x 1120 x 499	11.2/35	Silver Frame/ Grey Base	SSAIFRS + SSAIBG
				Black Frame/ Black Base	SSAIFRBLK + SSAIBBLK

Be reactive with our clip-on Tactical Header.

- Simply clips on to the top of Spring Sign frames.
- Ideal for short term or dual brand promotions - additional advertising space at minimal cost.
- 0.9mm rigid gloss white PVC panel ideal for screen/ digital print or vinyl graphics.
- Supplied complete with clips.
- Custom shapes available made to order (minimum order quantity 25).

Type	Size (mm)	Order Code
A1	582 x 200	THSM3A1



Fully Recyclable

Cyclone 2

Eye-catching, stable and stylish.



- Double sided 40" x 60" poster display.
- Front opening 50mm wide white Frameworkz snapframe border, excluding quadrant corner mouldings, can be printed in any design or is suitable for vinyl text or logos.
- Round corners throughout for safety.
- Back panel can be printed to offer brand presence when posters are not in use.
- 700 micron clear PET poster covers, fixed along top edge for security and ease of poster change.
- Black steel cradle with hard wearing pivot axles.
- Water-fillable black HDPE base with built-in wheels for ease of movement.

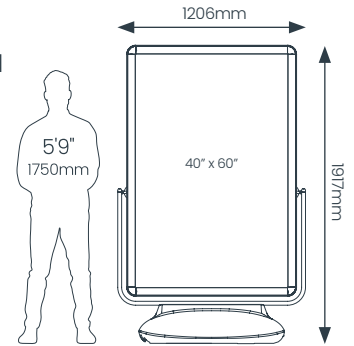

Hard wearing pivots for friction-free wind movement.

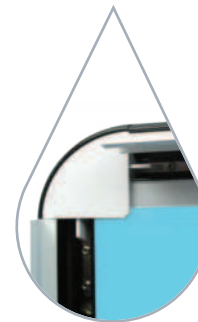

Snapframes for quick and easy poster change.



Purpose designed trolley and filling hose available (see page 42 for more details).

Cyclone 2's unique counter-balanced panel deflects wind safely and creates interest through movement:

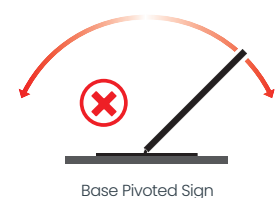
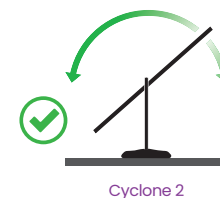
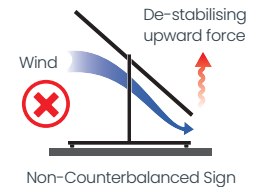
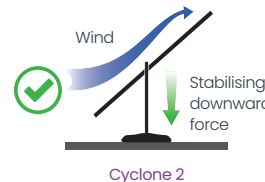

Recyclable: aluminium frame, steel cradle, PET poster covers, steel wheel axle, part recycled polyethylene base

Poster Size	Display Area (w x h mm)	O/A Dimensions (w x h x d mm)	Weight (kg) Empty/Full	Order Code
40" x 60"	980 x 1502	1206 x 1917 x 702	41/109	CYCLONE2 + SEN34BASE

Sentinel®

The ultimate forecourt poster sign.



- Sentinel® Tactical Header available separately (see page 24).
- Smooth rounded corners for safety.
- Stainless steel tamper-proof fixings retain poster cover at the top (not A1 size).
- Durable powder coated steel frame (50 x 25mm oval).
- Easy poster change by one person.
- Silver border and frame as standard.
- Printed back panel and printed borders available made to order.
- Magnetic sealed polycarbonate poster covers offer strength and superior poster protection.
- Black water-fillable base manufactured from recycled polyethylene.
- Built-in wheels - easy to move with our purpose designed trolley (see page 42 for details).



Sentinel® working hard for major brands across the country.



Magnetic poster covers for quick and easy poster change. Bottom opening for larger sizes, side opening for A1 (shown).



Custom colour steel frame (minimum order quantity 25), custom printed border and printed back panel are available made to order.



Recyclable: steel frame, polycarbonate poster covers, part recycled polyethylene base

Being able to display bold attention grabbing marketing messages outside a store or premises is key to driving footfall. Nothing does that better than Sentinel® - in a choice of 4 high impact poster sizes.

The Sentinel® Family

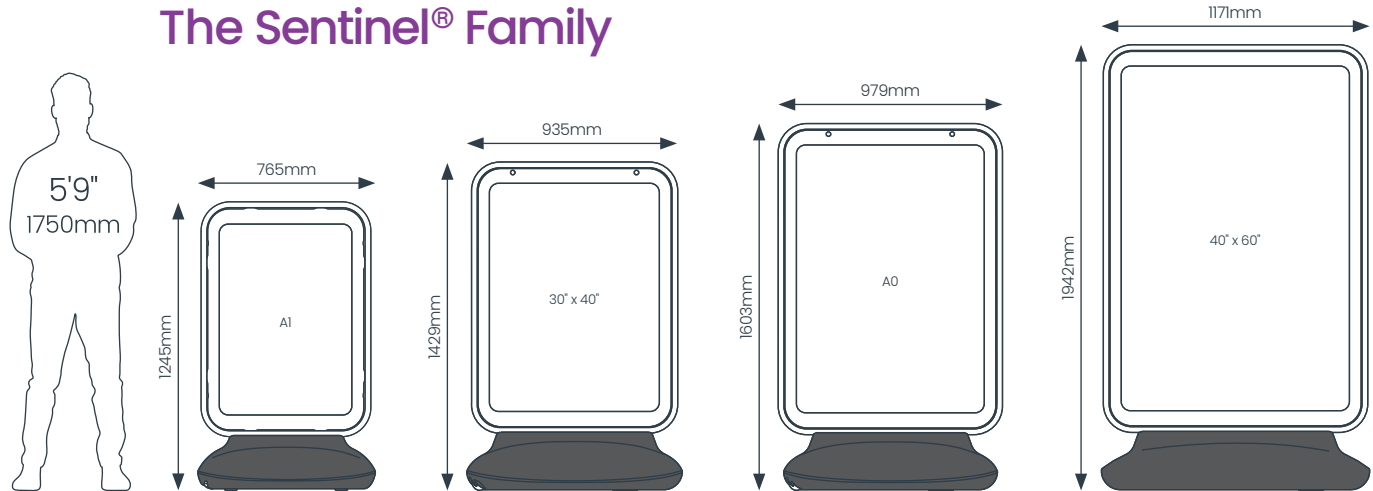

Poster Size	Display Area (mm)	O/A Dimensions (w x h x d mm)	Weight (kg) Empty/Full	Order Code
AI	580 x 830	765 x 1245 x 650	18.5/65	SENAISTD + SENAIBASE
30" x 40"	748 x 1004	935 x 1429 x 704	27/99	SEN34STD + SEN34BASE
A0	827 x 1178	979 x 1603 x 704	31/103	SENAOSTD + SEN34BASE
40" x 60"	1002 x 1512	1171 x 1942 x 894	37.5/150	SEN46STD + SEN46BASE

Instruction Video



Sentinel® Tactical Header

Be reactive with our clip-on Sentinel® header.



- Simply clips on to the top or side of Sentinel® frames.
- Ideal for short term or dual brand promotions - additional advertising space at minimal cost.
- 0.9mm rigid gloss white PVC panel ideal for screen/ digital print or vinyl graphics.
- Supplied complete with clips.
- Custom shapes available made to order (minimum order quantity 25).



Simply clips on top of Sentinel® and Sentinel® Banner frames (clips available separately).



Fully Recyclable

For use with	Size (mm)	Order Code
Sentinel® A1	625 x 200	THSENA1
Sentinel® 30" x 40" and Sentinel® Banner (742 x 996mm)	795 x 215	THSEN34
Sentinel® A0	870 x 230	THSENA0
Sentinel® 40" x 60" and Sentinel® Banner (996 x 1504mm)	1050 x 245	THSEN46



Defender

Permanent large format poster display.



- Front opening 38mm profile aluminium snapframes for quick and easy poster change.
- Anti-glare PET poster covers give excellent clarity.
- Heavy concrete base for optimum stability.
- Steel sub frame with panel area below poster frame suitable for permanent branding.
- Back panel can be printed to offer brand presence when posters are not in use.
- Silver anodised snapframe with white steelwork as standard.
- Custom colour frames available made to order (minimum order quantity 25).
- Please call our sales team for delivery charge costs.



Recyclable: aluminium snapframes, steel sub-frame, PET poster covers



Snapframes for quick and easy poster change.



Steel sub-frame panel suitable for permanent branding.

Poster Size	Display Area (w x h mm)	O/A Dimensions (w x h mm)	Base Diameter (mm)	Weight (kg)		Order Code
				Base	Frame	
30" x 40"	729 x 983	818 x 1447	600	53	15	DEF34WA + KIT01
40" x 60"	984 x 1492	1072 x 1855	800	80	24	DEF46WA + KIT02





Ecoflex (range overview)

Economical and eco-friendly – ideal for pavement, roadside and forecourt promotions.



Ecoflexlite shown



Unique patented design. Incredibly secure – wedge simply slots through panel & locks into place.

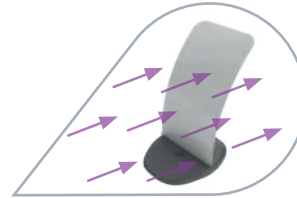

Ecoflex pavement signs tested to 60mph wind speeds (not Chalkboard or Totem options).

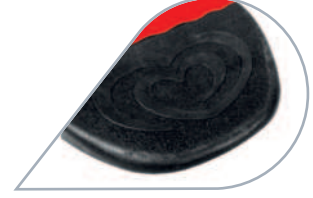

Bases with embossed logos available made to order (minimum order quantity 500).

- Fully recyclable.
- Lightweight, portable design.
- Gloss white aircraft grade aluminium panel – ideal for screen/digital print or vinyl graphics.
- Rounded corners for pedestrian safety.
- Maximum visual impact with optimised display area, plus panel shape opportunities.
- Option of black High Pressure Laminate chalkboard panels.
- Rugged recycled PVC base provides low centre of gravity and high stability.

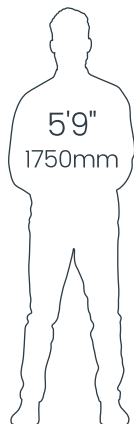

The Ecoflex Family

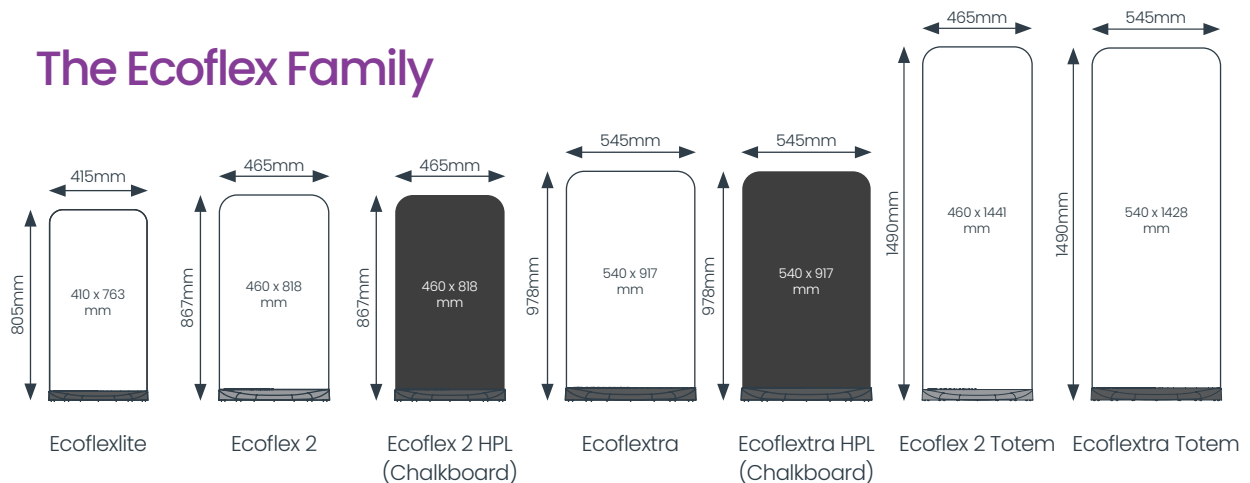

Ecoflexlite

Light on price, big on performance.

Instruction Video



- Ecoflexlite may be the smallest in our range, but it packs a punch with its 410mm x 763mm display area.
- Aircraft grade 0.9mm aluminium panel is ideal for screen/digital print or vinyl graphics.
- Unique patented wedge means assembly and disassembly in seconds with no tools required.
- Recycled PVC base provides great stability.
- Wind tested for maintenance-free use whatever the weather.
- Bases with embossed logos available made to order (minimum order quantity 500).



Wedge simply slots through panel and locks into place.

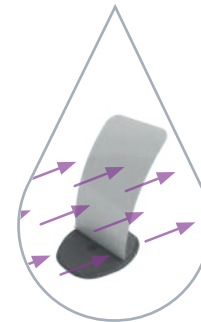

Tested to 60mph wind speeds.



Fully Recyclable

Panel Size (mm)	Display Area (mm)	O/A Dimensions (w x h x d mm)	Weight (kg)	Order Code
410 x 795	410 x 763	415 x 805 x 500	5.63	ECOFLEXLITE



Ecoflex 2

The Nation's top-selling pavement sign.

Instruction Video



- The top selling individual pavement sign in the UK.
- Mid sized 460mm x 818mm display area.
- Aircraft grade 1.2mm aluminium panel is ideal for screen/digital print or vinyl graphics.
- Unique patented wedge means assembly and disassembly in seconds with no tools required.
- Recycled PVC base provides great stability.
- Aluminium panels wind tested for maintenance-free use whatever the weather.
- High Pressure Laminate chalkboard option also available.
- Bases with embossed logos available made to order (minimum order quantity 500).
- Optional custom shaped and oversized panels for maximum impact (minimum order quantity 25).



Wedge simply slots through panel and locks into place.

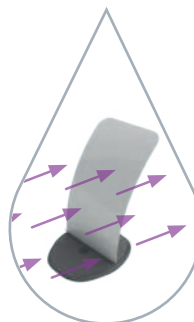

Tested to 60mph wind speeds (not Chalkboard option).



HPL chalkboard option available.



Fully Recyclable

Panel Options	Panel Size (mm)	Display Area (mm)	O/A Dimensions (w x h x d mm)	Weight (kg)	Order Code
Aluminium	460 x 850	460 x 818	465 x 867 x 540	7.8	ECOFLEX-2
Chalkboard	460 x 850	460 x 818	465 x 867 x 540	8.1	ECOFLEX-2-HPL



Ecoflextra

Bigger sign, bigger impact.

Instruction Video



- Designed for long range visibility to grab attention.
- Large 540mm x 917mm display area.
- Aircraft grade 1.2mm aluminium panel ideal for screen/digital print or vinyl graphics.
- Unique patented wedge means assembly and disassembly in seconds with no tools required.
- Recycled PVC base provides great stability.
- Aluminium panels wind tested for maintenance-free use whatever the weather.
- High Pressure Laminate chalkboard option also available.
- Bases with embossed logos available made to order (minimum order quantity 500).
- Optional custom shaped and oversized panels for maximum impact (minimum order quantity 25).



Wedge simply slots through panel and locks into place.

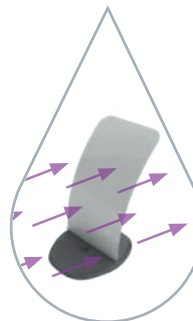

Tested to 60mph wind speeds (not Chalkboard option).



HPL chalkboard option available.



Fully Recyclable

Panel Options	Panel Size (mm)	Display Area (mm)	O/A Dimensions (w x h x d mm)	Weight (kg)	Order Code
Aluminium	540 x 952	540 x 917	545 x 978 x 540	11.3	ECOFLEXTRA
Chalkboard	540 x 952	540 x 917	545 x 978 x 540	11.7	ECOFLEXTRA-HPL



Ecoflex Custom Shaped Panels

Create truly unique and eye catching designs with custom shaped aluminium panels, brought to life with our vibrant screen and digital print.

Product	Max. Display Area dimensions(w x h mm)
Ecoflexlite	410 x 763
Ecoflex 2	623 x 918
Ecoflextra	696 x 1017



Minimum order quantity 25.



Ecoflex Chalkboard Panels

- 3mm High Pressure Laminate panel material is a tough writing surface ideal for traditional chalk and liquid chalk pens.
- Great for personalised messages, changing promotions and special offers.
- Options of branded panels using direct print or self adhesive vinyl.
- Liquid Chalk Pens available (see page 105).
- Chalkboard panels are available as standard on Ecoflex 2 and Ecoflextra models.

Note : Chalkboard panels can only be used in bases manufactured to suit a 3mm thick panel.

Ecoflex 2 Totem & Ecoflexextra Totem

Extra tall panels for maximum impact. Suitable for indoor use, or for outdoor use when fully sheltered from wind.



- 3mm thick Aluminium Composite (ACM) panels.
- Ideal for screen/digital print or vinyl graphics.
- Unique patented wedge means assembly and disassembly in seconds with no tools required.
- Recycled PVC base offers good stability.
- Suitable for indoor use, or outdoor use when fully sheltered from the wind.
- Totem panels can **only** be used in Ecoflex 2 or Ecoflexextra bases which are manufactured to suit a 3mm thick panel.
- Bases with embossed logos available made to order (minimum order quantity 500).



Fully Recyclable



Wedge simply slots through panel and locks into place.

Type	Panel Size (mm)	Display Area (mm)	O/A Dimensions (w x h x d mm)	Weight (kg)	Order Code
Ecoflex 2 Totem	460 x 1473	460 x 1441	465 x 1490 x 540	9.5	ECOFLEX-2-TOTEM
Ecoflexextra Totem	540 x 1463	540 x 1428	545 x 1490 x 540	12	ECOFLEXTRATOTEM



A-Board

A completely smooth panel for uninterrupted vinyl/print application.



- Double sided 500 x 700mm display area.
- Fixing free aluminium panel surface ideal for screen/digital print or vinyl graphics.
- Folds flat for easy storage and portability.
- Steel tube frame (32mm diameter), powder coated white as standard.
- Supplied pre-assembled and ready for use.
- Custom colour frames available made to order (minimum order quantity 200).



Fully Recyclable



Rounded corners for style and safety.

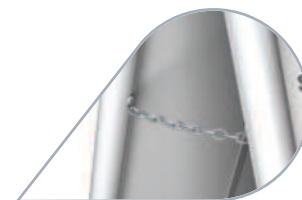

Chrome oval chain maintains optimum leg angle.

Display Area (mm)	O/A Dimensions (w x h x d mm)	Weight (kg)	Colour	Order Code
500 x 700	564 x 860 x 700	9	White	AB100W2FP



Budget A-Board

Our most economical A-Board.



- 3mm gloss white high impact polystyrene (HIPS).
- Double sided 480 x 812mm display area for self-adhesive vinyl graphics.
- Comes flat packed, pre-assembled with fixed hinges – simply adjust to the footprint that you require (maximum 680mm for optimum stability).
- Lightweight, folds flat for easy storage and portability.
- Rounded top corners for increased safety and style.
- Suitable for sheltered locations only.
- Chalkboard version available, suitable for use with Liquid Chalk Pens only (see page 105).



Fully Recyclable

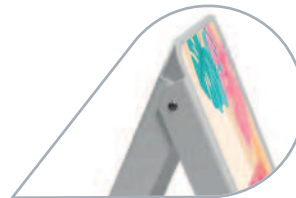

Fixed hinge for adjustable open width.

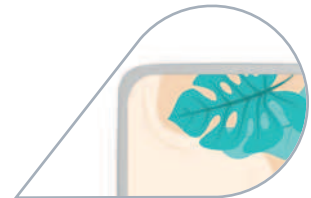

Rounded corners for added style and safety.

Display Area (mm)	O/A Dimensions (w x h x d mm)	Weight (kg)	Option	Order Code
480 x 812*	505 x 830 x 680	4.3	White	ABPSP
			Chalkboard	ABPSCB

*Recommended to allow 10mm border all round.



Waterbase A-Board

Our smallest A-Board offering.

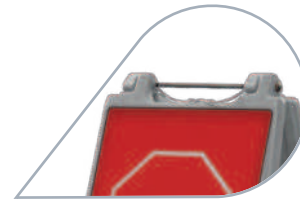

Built-in carry handle



- Durable polyethylene construction.
- Water fill (6.5 litres) or sand fill for optimum stability.
- Lightweight when empty and folds flat for easy transportation and storage.
- Graphic area 320 x 559mm (sticker inlay required).
- Open to any required width up to 570mm.
- We recommend using high tack vinyl for graphics.
- Vinyl inlay print and application available.
- Custom colours available made to order (minimum order quantity 500).



Waterfill panels for stability.

Display Area (mm)	O/A Dimensions (w x h x d mm)	Weight (kg)			Order Code
		Empty	Water-filled	Sand-filled	
320 x 559*	410 x 754 x 570	2.6	9.2	11.7	WBABGREY

*Recommended to allow 3mm border all round (recess is 326 x 565mm).



Fully Recyclable

Waterbase Pyramid

Eye catching double sided display pillar with sticker inlay graphic.



- Durable polyethylene construction.
- Water fill (5.5 litres) or sand fill for optimum stability.
- Simple push fit assembly.
- Graphic area 330 x 385mm with 12.5mm corner radius (sticker inlay required).
- Stands taller than most other pavement signs for eye catching double sided display.
- Supplied flat packed in 3 parts for ease of distribution.
- We recommend using high tack vinyl for graphics.
- Vinyl inlay print and application available.
- Custom colours available made to order (minimum order quantity 500).
- Barrier Ropes also available, see pages 114 and 202.



Fully Recyclable

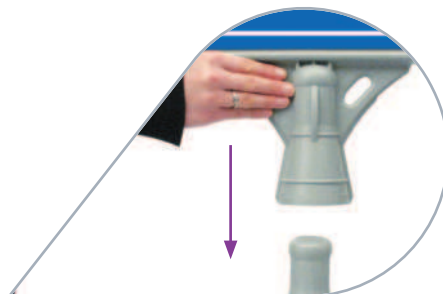

Parts simply push together.

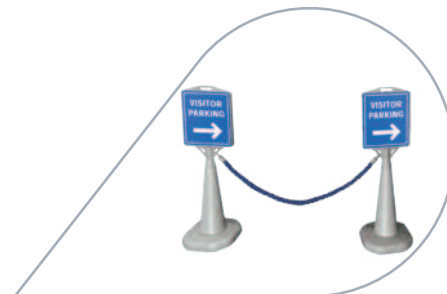

Waterbase pyramid barrier system.

Display Area (mm)	O/A Dimensions (w x h x d mm)	Weight (kg)			Order Code
		Empty	Water-filled	Sand-filled	
330 x 385	370 x 1125 x 370	2.3	7	11.4	WBPSGREY



Sentinel® Banner

Forecourt sign with printed banner display.

  **Recyclable:** steel frame, part recycled polyethylene base, optional PVC banner



- Steel frame with silver powder coated finish as standard.
- Custom colour frames available made to order (minimum order quantity 25).
- Black water-fillable polyethylene base, precisely calculated for optimum stability, made using recycled materials.
- Built in wheels and purpose designed trolley make it easy to move into position (see page 42 for details).
- Supplied complete with set of elasticated banner ties.
- Digitally printed double-sided banners available to order (750gsm reinforced light block PVC as standard).



Elasticated banner ties supplied.



Built-in wheels for ease of movement.



Purpose designed trolley and filling hose available (see page 42 for more details).

Banner Size (mm)	O/A Dimensions (w x h x d mm)	Weight (kg) Empty/Full	Order Code
742 x 996	935 x 1429 x 704	25/97	SEN34BANSTD + SEN34BASE
996 x 1504	1171 x 1942 x 894	38/146	SEN46BANSTD + SEN46BASE



Sign Covers

Sleeves over a forecourt poster sign for high-visibility promotion and medium-term campaigns.



- Promotes new service offers, new products and new site ownership/rebranding.
- For medium-term promotions typically 3 to 12 months.
- Borderless printed designs provide up to 38% more display area than the posters they cover.
- Suitable for the following signs in all sizes - Sentinel®, Defender, Sightmaster 3 and Spring Sign.
- Tear-proof polyester reinforced PVC material and stitched seams for excellent outdoor performance.
- Tethering holes in lower edge to suit cable-tie or similar for optional added security.
- For forecourt, supermarket, retail, service, exhibition and leisure-site locations.
- Custom sizes available.



Easy-fit cover - sleeves over sign.

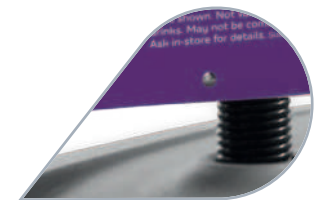

Tether holes in lower edge.

Sign Type	To fit over poster panel size	Cover Dimensions (mm)	Order Code
Fixed-Mount Frame	A1	792 x 1010	SCFIXA1
	30" x 40"	960 x 1210	SCFIX34
	A0	1039 x 1373	SCFIXA0
	40" x 60"	1214 x 1707	SCFIX46
Spring-Mounted Frame	A1	730 x 925	SCSPRNGA1
	30" x 40"	920 x 1092	SCSPRNG34
	A0	1015 x 1278	SCSPRNGA0
	40" x 60"	1170 x 1600	SCSPRNG46



Fully Recyclable

POW! Sign

Going above and beyond the standard rectangular poster or banner sleeve.



- Panel sleeve design enables easy and cost effective graphic updates.
- Maintenance free reinforced polypropylene sleeve (15mm thick).
- Vibrant, larger than life images for high impact promotion.
- Long range visibility to capture both pedestrians and motorists attention.
- Wholly customisable with endless text and image combinations.
- Made to order (see minimum order quantities on page 40).
- Freestanding - no groundwork needed.
- Water-fillable and concrete base options available.

Six stock colour water-fillable bases available made to order (minimum order quantity 10):



RAL 5013
Cobalt Blue

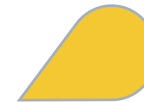

RAL 1003
Signal Yellow



RAL 3020
Traffic Red



RAL 6004
Blue Green



RAL 5015
Sky Blue



RAL 7016
Anthracite Grey



Recyclable: steel frame, steel fasteners, polyethylene base & steel axle

An innovation in large format double-sided signs, *POW!* delivers striking breakout shapes that are guaranteed to draw attention.



Custom Shape

- Ideal for breakout shapes and disruptive designs.



Trolley & Hose

- Purpose designed trolley & hose available separately (see page 42).

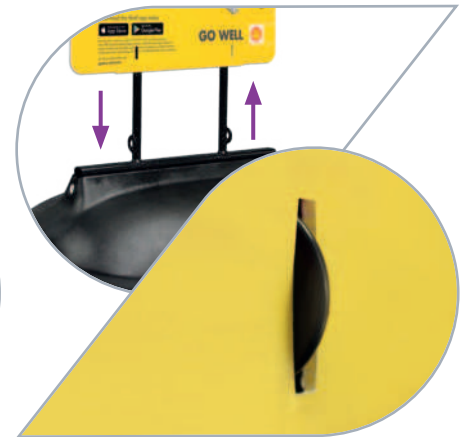

Panel

- Cost effective graphics, updatable in 1 minute.
- Panel slots into place effortlessly.

Base options



Waterfill Base

- Black water-fillable polyethylene.
- Built-in wheels for positioning (optional trolley available).
- Six stock colour bases available made to order (minimum order quantity 10).



Concrete Base

- For more permanent positioning.
- Lower cost material but generally higher distribution cost.



Bolt to Ground

- A permanent installation option.

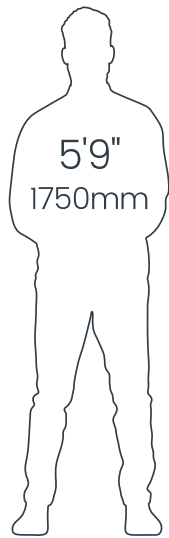

POW!

Max Display Area: 1180mm x 1353mm
(no minimum order quantity with waterfill base, minimum order quantity 10* with concrete base or bolt to ground frame).



POW! XL

Max Display Area: 1425mm x 1667mm
(no minimum order quantity with waterfill base, minimum order quantity 10* with concrete base or bolt to ground frame).

Panel Fitting

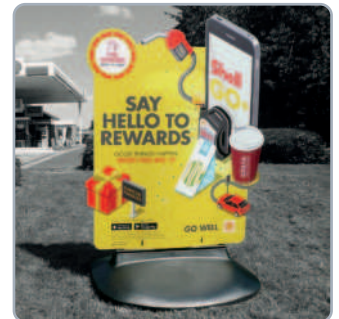

*Replacement panels have no minimum order quantity.



POW! with waterfill base

	Min. O/A dimensions (w x h x d mm)	Max. O/A dimensions (w x h x d mm)	Weight (kg)		Order Code
			Empty	Full	
POW!	935 x 1320 x 704	1180 x 1623 x 704	16.5	88.5	POWMEDWF + SEN34BASE
POW! XL	1171 x 1579 x 894	1425 x 1944 x 894	25	137	POWLRGWF + SEN46BASE



POW! with concrete base

	Min. O/A dimensions (w x h x d mm)	Max. O/A dimensions (w x h x d mm)	Weight (kg)	Order Code
POW! XL	800 x 1408 x 800	1425 x 1773 x 800	96.5	POWLRCF + KIT02



POW! for bolt to ground (frame and sleeve only)

	Min. O/A dimensions (w x h x d mm)	Max. O/A dimensions (w x h x d mm)	Weight (kg)	Order Code
POW! XL	745 x 1308 x 100	1425 x 1673 x 100	11.5	POWLRCF



POW! sleeve only

	Min. O/A dimensions (w x h x d mm)	Max. O/A dimensions (w x h x d mm)	Weight (kg)	Order Code
POW! XL	745 x 1302 x 12	1425 x 1667 x 12	5.3	POWLRC

Trolley and Hose

Convenient assistance for a selection of our large format signs.



- Purpose designed flat pack trolley for easy and safe movement of Sentinel[®], Sentinel[®] Banner, Cyclone 2, large-based Sightmaster 3 and POW!
- 3m hose with tap connector also available for convenient base filling.



Recyclable: steel trolley handle



Item	O/A Dimensions (mm)	Weight (kg)	Order Code
Trolley	225 x 1220 x 225	2.5	TROLLEY
Hose	3000 x 13	1	SENHOSE
Adaptor*	90 x 45 x 48	0.125	TROLLEYADAPTOR

* Only used with old Sightmaster 2 units.



Chalk Insert Panels

Turn any poster display into a chalkboard display, with these simple and inexpensive insert panels.



A-Master with Chalk Insert Panel.

- High strength 500 micron black polypropylene (textured surface to front, smooth matt reverse).
- Suitable for use with Liquid Chalk Pens (see page 105).
- Suitable for screen/digitally printed graphics or vinyl application.
- Resistant to dirt and chemicals – stays looking new for longer.
- High temperature tolerance – long life even in outdoor use.
- Available in 3 stock sizes: A2, 20" x 30" and A1.
- Custom sizes available made to order (up to 650 x 1100mm).

A selection of products perfectly suited to Chalk Insert Panels:



Sightmaster 3 (page 18).



Swinger Poster Pocket (page 6).



Booster (page 17).



Slimlok Poster Case (page 90).



Snapframes (page 83).



Headlinerlite (page 147).



i-Stand (page 119).



Fully Recyclable

Poster Size	O/A Dimensions (mm)	Order Code
A2	420 x 594	INFA2CCB
20" x 30"	508 x 762	INF2030CCB
A1	594 x 841	INFA1CCB



Premier A-Board

Unique design that leads the market on performance and functionality.

Instruction Video



Available in 2 sizes and 2 stock finishes with a choice of panel materials.

- 38mm x 38mm powder coated steel frame.
- Satin black and satin wood grain stock finishes.
- Unique hard-wearing rubber hinges allow feet to self-level on uneven surfaces and offer finger protection when handling.
- Reversible panels for added message flexibility and convenience.
- Fully assembled and ready for use straight out of the box.
- Custom colour frames available made to order (minimum order quantity 25).

Panel material options

- 3mm black high pressure chalkboard laminate – for traditional chalk or liquid chalk pens (see page 105).
- 3mm gloss white aluminium composite (ACM) – strong, light and very rigid.
- 5mm satin/matt white foam PVC – strong and lightweight.

Printed/shaped panel options.

- Custom shaped top edge available for all panel materials made to order (minimum order quantity 25).
- Direct to surface digital/screen print available.



Recyclable: Steel frame, steel stays, ACM panels, foam PVC panels

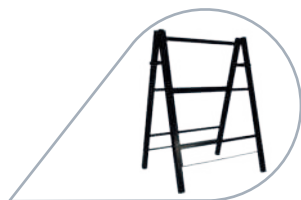

Frame only also available.



Liquid Chalk Pens available for use with Chalkboard panels, see page 105.



Stylish locking arms.



Hard wearing rubber hinges.



Slide-in reversible panels in either...



High pressure chalkboard laminate.



White aluminium composite (ACM) or Foam PVC.

OR

Wood Effect Finish

- Beautiful wood-grain patterned powder-coating in a satin sheen finish.
- Out performs real wood and maintains a high quality new wood appearance for longer.
- Other patterns/colours available (minimum order quantity and extended lead times apply).

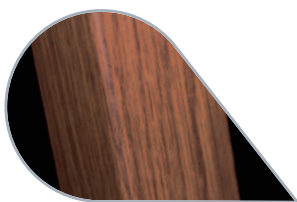

Frame Colour	Size (mm)	Panel Material	Display Area (mm)	O/A Dimensions (w x h x d mm)	Weight (kg)	Order Code
Black Steel Frame	Small	3mm Black High Pressure Chalkboard Laminate	542 x 809	674 x 920 x 600	12	PREMASMMHPL
		3mm Gloss White Aluminium Composite (ACM)			11	PREMASMMACM
		5mm White Foam PVC			10.5	PREMASMMFOAM
Black Steel Frame	Large	3mm Black High Pressure Chalkboard Laminate	709 x 1045	843 x 1184 x 705	19	PREMALGMHPL
		3mm Gloss White Aluminium Composite (ACM)			16.5	PREMALGMACM
		5mm White Foam PVC			15.5	PREMALGMFOAM
Wood Effect Steel Frame	Small	3mm Black High Pressure Chalkboard Laminate	542 x 809	674 x 920 x 600	12	WEMPRDOSMHPL
		3mm Gloss White Aluminium Composite (ACM)			11	WEMPRDOSMACM
		5mm White Foam PVC			10.5	WEMPRDOSMFM
Wood Effect Steel Frame	Large	3mm Black High Pressure Chalkboard Laminate	709 x 1045	843 x 1184 x 705	19	WEMPRDOLGHPL
		3mm Gloss White Aluminium Composite (ACM)			16.5	WEMPRDOLGACM
		5mm White Foam PVC			15.5	WEMPRDOLGFM
Satin Black Frame Only	Small	-	-	674 x 920 x 600	8	METALFRAMEASSYSMCH
	Large	-	-	843 x 1184 x 705	11.5	METALFRAMEASSYLGRCH
Wood Effect Frame Only	Small	-	-	674 x 920 x 600	8	WEMFRAMEDOSM2
	Large	-	-	843 x 1184 x 705	11.5	WEMFRAMEDOLRG2

Chalk A-Boards by Woodworkz®

Woodworkz® is our joinery-quality brand of in-house manufactured real wood sign and display products.

We only use sustainable and certified timber sourced from approved sawmills and distributors.

All models feature:

- 2-coat, low VOC, stained and satin lacquered for excellent weather protection.
- Stock 'Country Oak' finish.
- Good grain definition to emphasise real wood appeal.
- Single side locking-stay for stability on small and medium frames, 2 side locking-stays on large frames.
- Non-slip rubber feet.
- Precision mitres and joints – joinery quality.
- Hard-wearing laminate chalk panels for traditional chalk or liquid chalk pens (see page 105).
- Custom colour frames and sizes available made to order (minimum order quantity 10).

Large Premium Full Frame

Medium Premium Reversible

Small Standard Full Frame



Liquid Chalk Pens available for use with Chalkboard panels (see page 105).

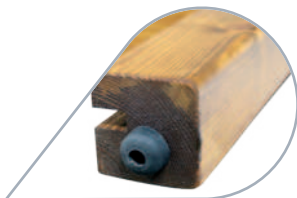

Rubber feet.

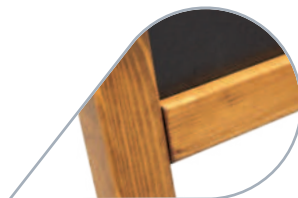

Durable finish.



Precision joinery.



Locking stay.

Our Woodworkz® Chalk A-Board range offers 7 models across 3 styles.

Direct to surface print available.



Standard Full Frame

- 3 sizes – small, medium and large.
- 45 x 21mm frame profile.
- 6mm exterior chalk-face laminated MDF panels.
- Fully recyclable.



Premium Full Frame

- 2 sizes – medium and large.
- 45 x 45mm frame profile.
- 6mm exterior chalk-face laminated MDF panels.
- Fully recyclable.



Premium Reversible

- 2 sizes – medium and large.
- 45 x 45mm frame profile.
- 3mm high pressure laminate (HPL) reversible slide-in curve-topped panels.
- Recyclable: frame, steel locking stays, feet and hinges.

Style	Size	Display Area (mm)	O/A Dimensions (w x h x d mm)	Weight (kg)	Order Code
Standard Full Frame	Small	367 x 572	470 x 776 x 500	5	WCABCOSS
	Medium	572 x 772	671 x 967 x 613	8.5	WCABCOMS
	Large	702 x 1072	801 x 1255 x 784	13	WCABCOLS
Premium Full Frame	Medium	572 x 772	671 x 972 x 659	11.5	WCABCOMP
	Large	702 x 1072	801 x 1260 x 830	17	WCABCOLP
Premium Reversible	Medium	537 x 798	637 x 950 x 604	9.5	WCABCOMPRV
	Large	704 x 1034	804 x 1176 x 736	13	WCABCOLPRV



Recyclable

Banner Frame

Lightweight aluminium banner frame for ground siting.

Wall mounted variant available – see page 99

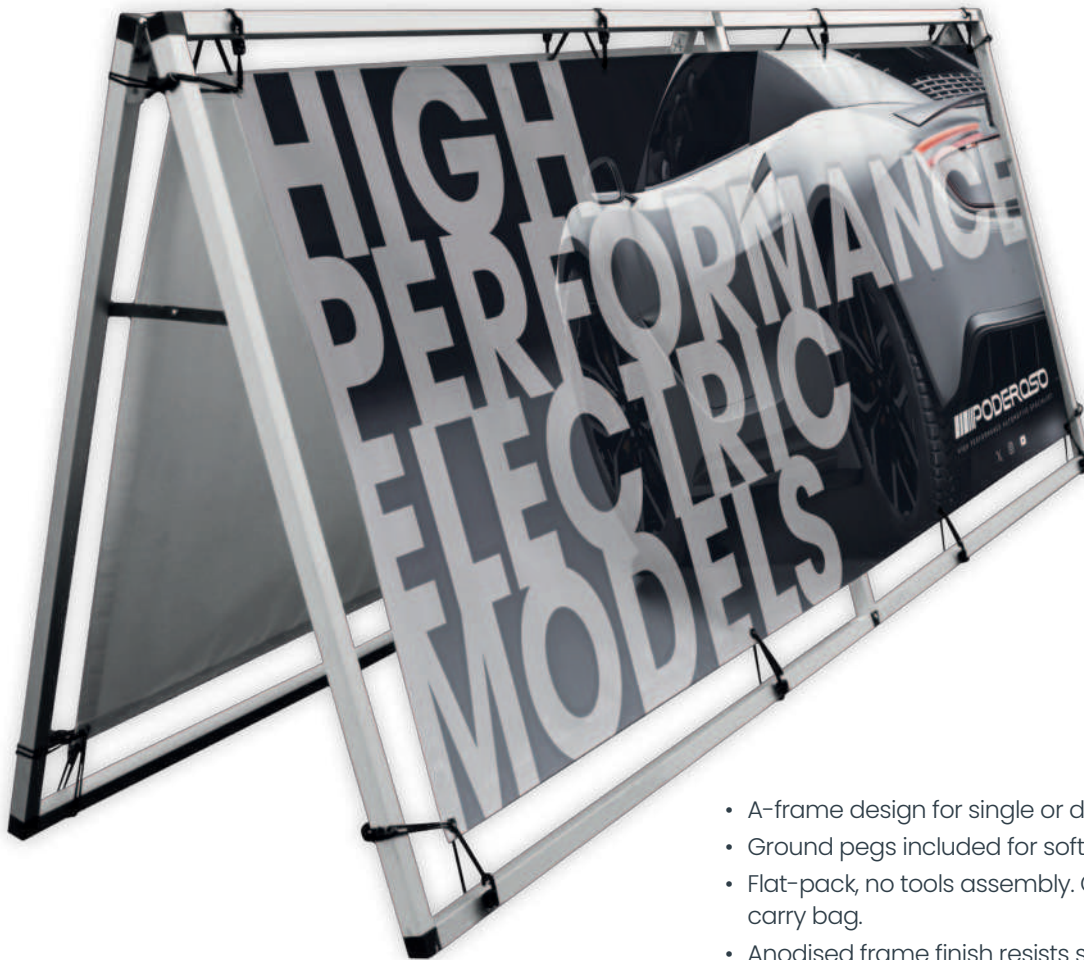

Simple push-fit assembly.

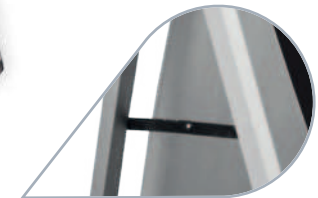

Hinged stays.

- A-frame design for single or double-sided banners.
- Ground pegs included for soft ground anchoring.
- Flat-pack, no tools assembly. Complete with padded carry bag.
- Anodised frame finish resists scratches to maintain best appearance.
- Self-adjusting bungee hooks hold eyeleted banners under tension.
- Bungees included.
- Recommended banner size: 2840 x 1090mm.
- Use with caution outdoors – light winds only.
- Printed Banners available.



Recyclable: aluminium tubes, steel stays, steel pegs, steel hinges

Display Area (mm)	O/A Dimensions (w x h x d mm)	Weight (kg)	Order Code
2840 x 1090	3000 x 1250 x 800	6.5	BANFRAME

Bollard Wraps

Transform any bollard into a high impact advertisement.



- Simply pops over existing bollards for effective seasonal marketing or promotion of new products and services.
- Suitable for a wide range of bollard sizes from 100mm - 200mm diameter.
- Choose from 3 heights: 800mm, 1000mm and 1200mm.
- 3 sided and 4 sided options available.
- Graduated tabs allow quick and easy assembly without the need for any tape, fixings or tools.
- Fine-fluted 3mm Correx polypropylene for resilient outdoor use.



Fully Recyclable

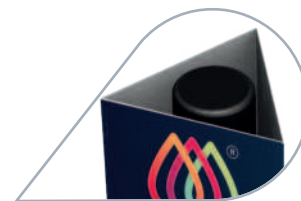

Bollard Wrap detail view.



Flying Banners

The popularity of Flying Banners, sometimes referred to as Event Flags, Sail Flags, Beach Flags or Feather Flags, has grown tremendously in recent years.

Proud to be at the forefront of this revolution, our high quality printed textile flags are supported on high-strength carbon composite poles and friction-free bearing spindle, on a choice of base, ground spike or bracket mount.

We have invested heavily in research, product development and testing to ensure materials, print and product performance are amongst the best available whilst offering very competitive pricing.

Outdoor Performance

Naturally, Flying Banner life span depends on how and where they are used.

Teardrop flags generally last longer than Feather flags as the banner fabric is held in tension and experiences less movement.

Whichever style you choose we recommend taking them in overnight and avoid use in strong winds (i.e. 24+ mph wind speeds/Beaufort scale 6). Failure to do so will significantly shorten the lifespan of the product.

* Flag templates available on request, if own flag production preferred.

A choice of 3 shapes and 3 sizes.



Leading Quality and Performance

Friction-Free Bearing Spindle

Our intelligently designed and engineered steel bearing spindle features in all our outdoor base and mounting bracket solutions (see page 56).

Friction-free rotation allows the flag to easily align to the wind, minimising stress and optimising flag visibility, performance and life-span.

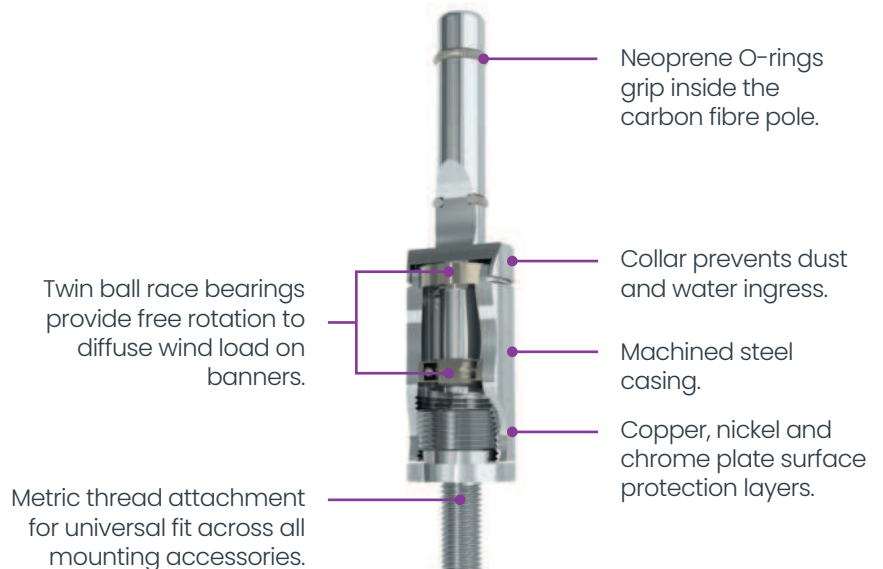

Carbon Composite Banner Poles

Our light-weight, high-strength, sectional poles come with a 3 year manufacturer's warranty. They are stronger and more stress/gust resistant than any aluminium pole offering.

Reuse for years with replacement flags as required.

Flag Materials

There is a choice of standard 110gsm close-weave or 115gsm air-mesh polyester textiles, both offering an excellent combination of strength and image vibrancy.

Small holes in air-mesh allows some air to pass through the fabric thus reducing wind fatigue on the flag. This makes it a good choice for windy situations, particularly in combination with the elasticated pole sleeve.

Recycled 'rPET' textile available at additional cost. Minimum order quantities may apply subject to confirmation at time of enquiry.

Sublimation Printing

All flying banner flags are printed by a dye-sublimation process which uses special inks and a post-print heating process to 'fix' the ink into the fabric, making it resilient and washable as well as maximising the mirror image show-through on the reverse. Double-sided printed flags also available for medium Feather Flying Banners.

Flag Pole Sleeves

The majority of our flags are produced with printed, non-elasticated wrap-around pole sleeves, providing maximum possible print area. When extra durability is required there is the option of a reinforced black or white elasticated sleeve. This would be recommended for exposed or unattended locations, such as roadside and 24/7 retail sites where the flag may not be taken in overnight.

Finishing

To complete the attention to detail all Flying Banners come with draw string tethers to adjust tensioning, double-stitched hems and reinforced pole sleeve ends for optimum flag life.



High strength.

Sectional poles.

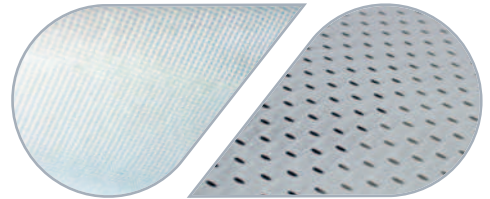

Standard.

Air-mesh.



Front.

Reverse.

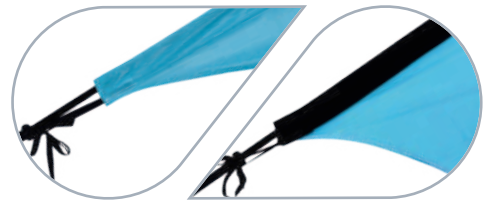

Wrap-around.

Black Elasticated.



Draw string tether.

Double stitched hems.

Feather Flying Banner

Feather shaped banner which flutters and rotates in the wind.

Instruction Video



Showing white reinforced elasticated pole sleeve and Base Plate.

- High strength sectional carbon fibre pole.
- Market leading detail, quality and performance.
- Printed flags in standard or airmesh polyester textile to order.
- Choice of mounting accessories available.
- Printed non-elasticated wrap-around pole sleeves give maximum possible printed display area.
- We recommend an elasticated pole sleeve for increased durability.

Double-sided option for popular medium Feather flags.

A twin layer of standard fabric with central 'block-out' liner offers true double-sided print capability and the option of a different design each side. Make sure to combine with the upgraded Medium (double sided) Pole (order code: DSFBFMD).

Note: due to added weight double sided flags will not flutter in the wind in the same way as standard flags.

Feather Pole & Bag	O/A Height (mm)	Pole & Bag Weight (kg)	Order Code
Small	2493	0.28	FBFSM
Medium	3480	0.47	FBFMD
Medium (Double Sided)	3480	0.75	DSFBFMD
Large	4688	0.81	FBFLG



Feather Flag	Flag Size Wrap around (mm)	Order Code Printed flags with Wrap around printed pole sleeve	Flag Size Elasticated (mm)	Order Code Printed flags with reinforced elasticated black pole sleeve	Order Code Printed flags with reinforced elasticated white pole sleeve
Small	698 x 2323	FBFSMBAN(SW)	701 x 2246	FBFSMBANBEH(SW)	FBFSMBANWEH(SW)
Medium	750 x 3251	FBFMDBAN(SW)	753 x 3191	FBFMDBANBEH(SW)	FBFMDBANWEH(SW)
Medium (Double Sided)	n/a	n/a	753 x 3191	DSFBFMDBANBEH	DSFBFMDBANWEH
Large	850 x 4421	FBFLGBAN(SW)	853 x 4351	FBFLGBANBEH(SW)	FBFLGBANWEH(SW)

For a printed air-mesh flag add 'A' to the end of the appropriate order code above.



Teardrop Flying Banner

Teardrop shaped banner which rotates in the wind.

Instruction Video



Showing wrap-around pole sleeve and Tank Base.

- High strength sectional carbon fibre pole.
- No fluttering means less distress and increased durability.
- Market leading detail, quality and performance.
- Printed flags in standard or airmesh polyester textile to order.
- Choice of mounting accessories available.
- Printed non-elasticated wrap-around pole sleeves give maximum possible printed display area.
- We recommend an elasticated pole sleeve for increased durability.

Teardrop Pole & Bag	O/A Height (mm)	Pole & Bag Weight (kg)	Order Code
Small	2250	0.34	FBTSM
Medium	3340	0.70	FBTMD
Large	4925	1.06	FBTLG



No Tools Assembly

Teardrop Flag	Flag Size Wrap around (mm)	Order Code Printed flags with Wrap around printed pole sleeve	Flag Size Elasticated (mm)	Order Code Printed flags with reinforced elasticated black pole sleeve	Order Code Printed flags with reinforced elasticated white pole sleeve
Small	771 x 2060	FBTSMBAN(SW)	800 x 1992	FBTSMBANBEH(SW)	FBTSMBANWEH(SW)
Medium	1048 x 3130	FBTMDBAN(SW)	1067 x 3062	FBTMDBANBEH(SW)	FBTMDBANWEH(SW)
Large	1144 x 4122	FBTLGBAN(SW)	1177 x 4052	FBTLGBANBEH(SW)	FBTLGBANWEH(SW)

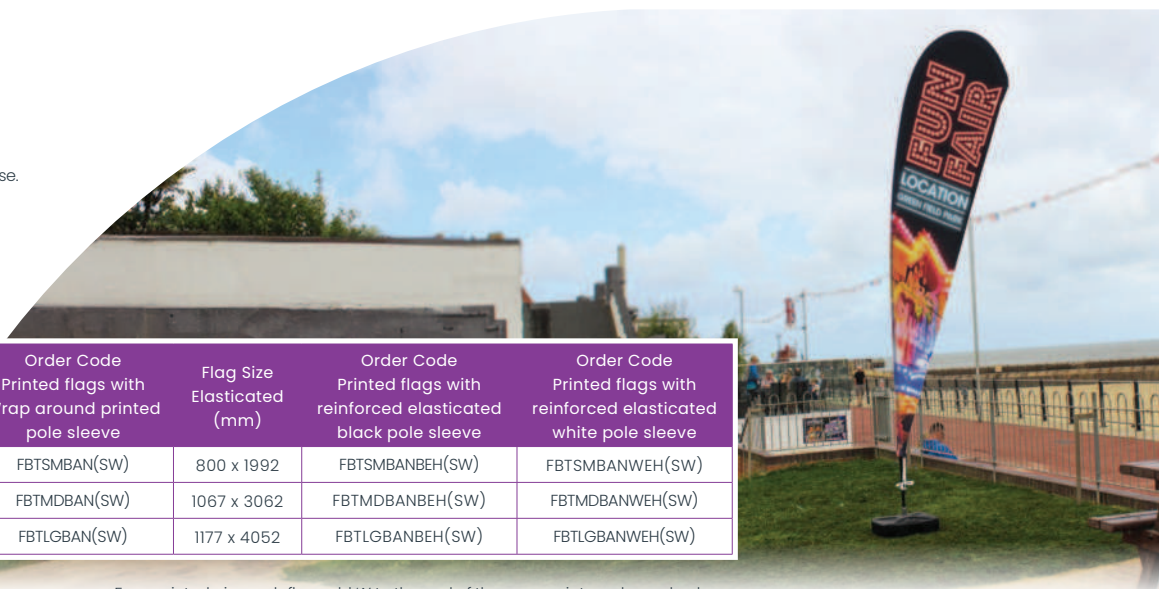

For a printed air-mesh flag add 'A' to the end of the appropriate order code above.

Rectangle Flying Banner

Instruction Video



Rectangle shaped banner which flutters and rotates in the wind.



Showing black reinforced elasticated pole sleeve and Cross Base and Water Bag.

- High strength sectional carbon fibre pole.
- Horizontal top pole ensures branding is always on show, with or without wind.
- Market leading detail, quality and performance.
- Printed flags in standard or airmesh polyester textile to order.
- Choice of mounting accessories available.
- Printed non-elasticated wrap-around pole sleeves give maximum possible printed display area.
- We recommend an elasticated pole sleeve for increased durability.

Rectangle Pole & Bag	O/A Height (mm)	Pole & Bag Weight (kg)	Order Code
Small	2115	0.44	FBRSM
Medium	2897	0.65	FBRMD
Large	4020	1.05	FBRLGUS



 **No Tools Assembly**

Rectangle Flag	Flag Size Wrap around (mm)	Order Code Printed flags with Wrap around printed pole sleeve	Flag Size Elasticated (mm)	Order Code Printed flags with reinforced elasticated black pole sleeve	Order Code Printed flags with reinforced elasticated white pole sleeve
Small	780 x 1770	FBRMBAN(SW)	782 x 1752	FBRMBANBEH(SW)	FBRMBANWEH(SW)
Medium	780 x 2530	FBRMDBAN(SW)	782 x 2552	FBRMDBANBEH(SW)	FBRMDBANWEH(SW)
Large	780 x 3580	FBRLGBAN(SW)	782 x 3602	FBRLGBANBEH(SW)	FBRLGBANWEH(SW)

For a printed air-mesh flag add 'A' to the end of the appropriate order code above.



Mounting Accessories For Flying Banners

Tank Base

- A universal Flying Banner mounting option that works across all ground surfaces, whether soft or hard.
- Purpose designed water or sand fillable black HDPE bases with our leading low-friction bearing spindle for all flag sizes.
- Two size options. The large Tank Base is recommended for medium and large Flying Banners.
- Built-in handle for ease of moving even when full – satisfies manual handling guidelines. Large Tank Base includes integrated wheels.
- Wide fill-hole for ease of filling – screw cap includes leak-free rubber seal.
- Purpose engineered design – far superior to commonly used ‘parasol’ type base offerings by others.

Small Tank Base



Large Tank Base



Large tank base includes wheels.



Small tank base in use.

Item	O/A Dimensions (w x h x d mm)	Weight (kg)			Order Code
		Empty	Water-filled	Sand-filled	
Small Tank Base + Spindle	455 x 245 x 455	2.0	15	23.0	FBSMTK+TKBRG
Large Tank Base + Spindle	584 x 280 x 584	3.3	24	36	FBLGTK+TKBRG
Spindle only (for small or large)	100 x 132 x 100	0.8	-	-	TKBRG



Fully Recyclable

Mounting Accessories For Flying Banners

Base Plate



Recyclable: steel base plate, steel spindle



Item	O/A Dimensions (w x h x d mm)	Weight (kg)	Order Code
Small Base Plate	300 x 300 x 9 (plate 6mm thick)	4.2	FBBASEPLATESM
Large Base Plate	400 x 400 x 9 (plate 6mm thick)	7.3	FBBASEPLATELG

- Stylish low profile base for interior use only eg. exhibitions, retail, malls, showrooms, sport and leisure venues.
- Matt black non reflective base finish.
- Integral spigot grip-feature holds pole/flag position and desired best line of view.
- Low profile – Base Plate sits just 9mm above floor.
- 3mm thick foam foot pads protect floor and ease lifting.
- 2 sizes: Small Base Plate for all small flags and Large Base Plate for all medium and large flags.
- Allen Key tool included to fix spigot to base.

Cross Base and Water Bag



Recyclable: steel cross base, steel spindle

Item	O/A Dimensions (w x h x d mm)	Weight (kg)	Order Code
Cross Base	Length: 840 Width: 60	4	FBBASE(2)
Water Bag	540 diameter	Empty: 0.4 Full: 10.6	FBBAG(H)



- A traditional Flying Banner base solution for hard ground indoors or out.
- Compact packing can make this a popular choice when transport space to an event is at a premium.
- Powder coated grey steel cross base, with high quality low friction bearing spindle for smooth flag rotation.
- Holes at end of feet for pegging to soft ground if required (pegs not supplied).
- Optional water bag for added stability.



Wheel Base

- Forecourt-friendly design - enables Flying Banners to be situated in a matter of seconds.
- Black powder coated steel feet with low friction bearing spindle.
- V shape allows base to be wedged under any parked vehicle wheel (or driven onto).
- Suitable for all tyre sizes.
- Folding design for easy storage.
- Suited for use with High Rise Flying Banner Kits (see page 60).



Weight (kg)	Order Code
4	FBWHEEL(2)

Concrete Base

- Heavy duty 67kg base solution - ideal for semi-permanent positioning.
- High quality low friction bearing spindle for smooth flag rotation.
- Spindle assembly comes with 4 bolts and spanner (concrete base pre-threaded).
- Lever points provided for ease of movement.
- Due to weight of base, pallet delivery is necessary.



Item	O/A Dimensions (w x h x d mm)	Weight (kg)	Order Code
Concrete Base with Bearing Spindle	600 (dia.) x 235 (h)	67	FBCONC + FBCONCBRG



Bracket Mount Bearing Spindles (Angled, Vertical, Horizontal)



- Friction-free bearing spindle on a choice of 3 different fixing plates for vertical or horizontal mounting.
- Fixings not supplied – it is up to the installer to choose the appropriate fixing for the situation.
- Suitable for parapet walls, posts, fencing etc.

Item	Weight (kg)	Order Code
Angled	0.83	FB25DGWALBRG
Vertical	0.85	FBVERTWALBRG
Horizontal	0.7	FBCONCBRG

Note: if considering an angled mount for a shop or building frontage then we recommend use of small Teardrop Flying Banners only – to avoid flag damage against the wall in the event of wind rotation.



Ground Spike



Ground Spike Diagram

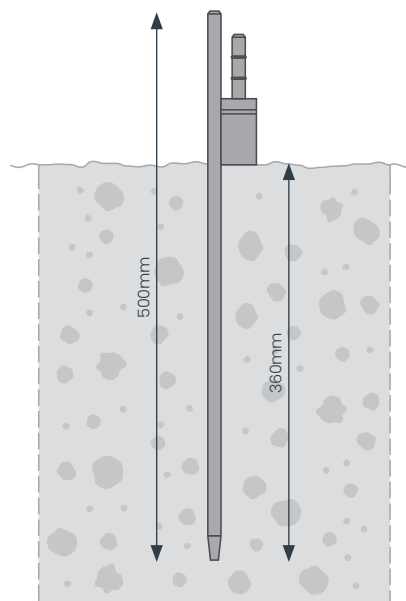

- Steel spike for soft ground or sand.
- Bearing spindle for smooth flag rotation.
- Male pole connections with O-rings provide a perfect and secure fit as well as offering free rotation to deflect wind loading.

Weight (kg)	Order Code
1.2	FBSPIKE(2)



High Rise Flying Banner Kits

Additional ground clearance for unobscured banner visibility.

- Kits include pole and 'high rise' conversion kit.
- Perfectly suited to car sales forecourts, flag will fly clear of vehicle for unobstructed promotion and no risk of damage to vehicle paintwork.
- Also suitable for providing clearance for fencing, gateposts, hedging and densely crowded locations.
- Compatible for use with; Tank Bases, Base Plate, Cross Base, Concrete Base, Wheel Base and Vertical or Horizontal Bracket Mount Bearing Spindle (see pages 56-59).
- Note - flags need to be purchased separately (see pages 53-55).

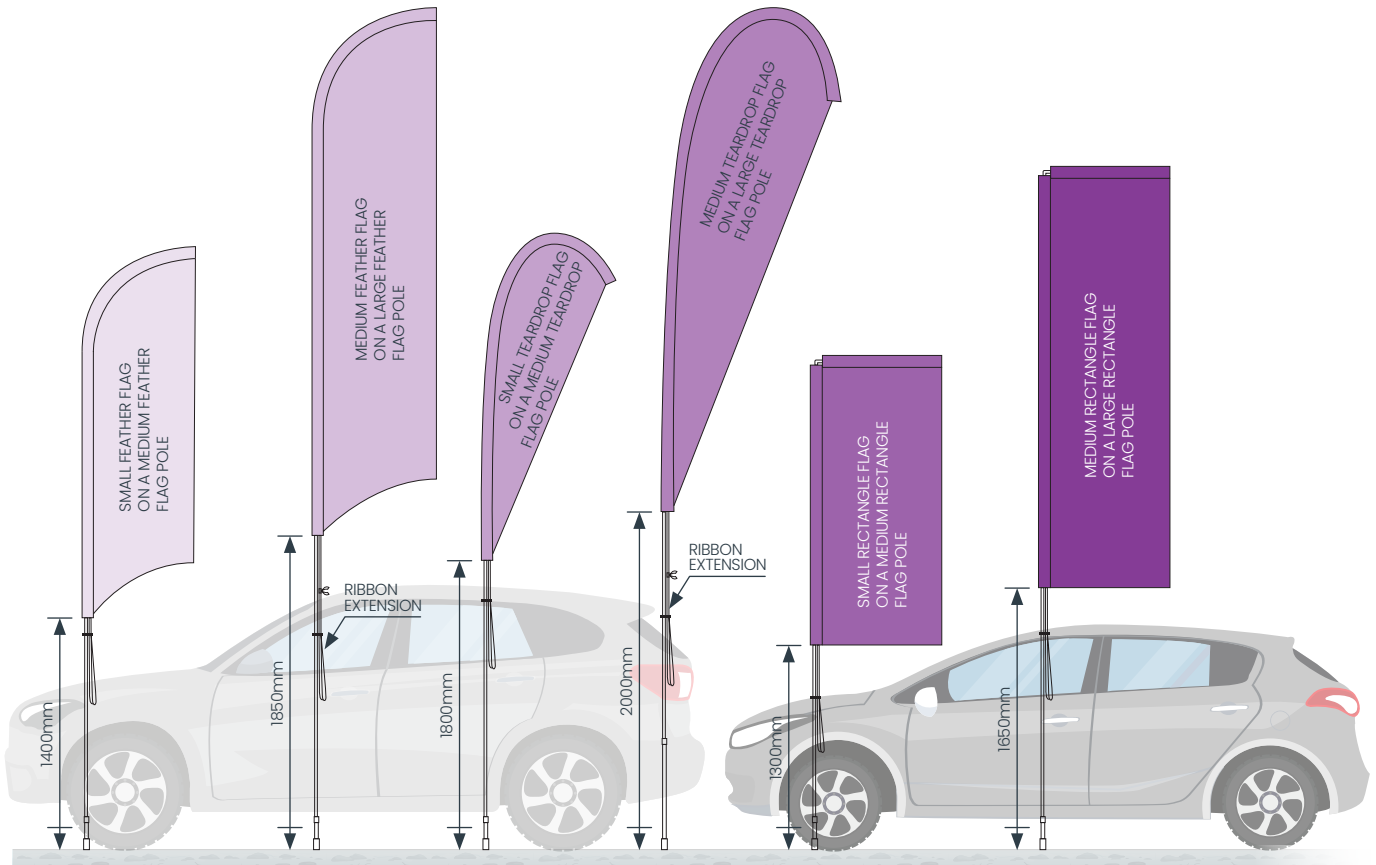

Order Code	Order Code	Order Code	Order Code	Order Code	Order Code
HRFBKIT1	HRFBKIT2	HRFBKIT3	HRFBKIT4	HRFBKIT5	HRFBKIT6



All flag shapes available (medium size flag examples shown above).



Fully Recyclable



Outdoor
Freestanding/Floor Mounted

Giant Pole

5.4m high attention grabbing outdoor display.

Instruction Video



- High impact display for 1.1 x 4.1m textile flag.
- Ideal for forecourts, shopping centres, exhibitions and events.
- 2-part water-fillable polyethylene base for optimum stability.
- Telescopic aluminium pole with silver anodised finish (54mm diameter at base).
- Single and double sided printed flags available.
- Printed by dye sublimation – see page 191 for more details.
- Pole and base carry bags included.

Double Sided Flags

A twin layer of standard fabric with central 'block-out' liner offers true double-sided print capability and the option of a different design each side.

Note: Due to added weight double sided flags will not flutter in the wind in the same way as standard flags.

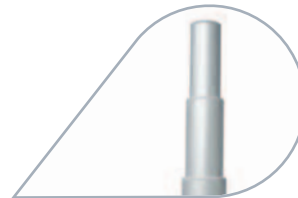
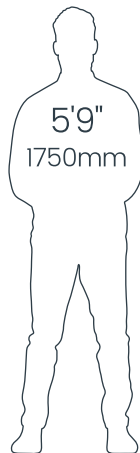

Telescopic pole.



360° rotating flag arm.



2 part base for ease of transportation.



Water-fillable base with clip-in leg fixings.



Recyclable: aluminium pole, polyethylene base

Item	O/A Dimensions (w x h x d mm)	Weight (kg) Empty/Full	Availability	Order Code
Giant Pole hardware (exc. Flag)	Base: 800 x 180 x 800 O/A height: 5.4m	15/70	Stocked	GIANTPOLE(H)
Printed Flag Single Sided	1100 x 4100	–	Made to order	GIANTBANNERSS(SW)
Printed Flag Double Sided	1100 x 4100	–	Made to order	GIANTBANNERDS(SW)

Adfresco® Café Barrier

Patent No. 2472843

Advertise and manage space simultaneously.

Manufactured to our patented design and quality standards, the Adfresco® Café Barrier range combines style, market leading features and performance at an attractive price.

In a choice of styles, sizes and finishes it includes the lower specification Adfresco® LT pole and base to cater for the tighter budget or for indoor/sheltered outdoor use.



Stylish, strong and effective –Adfresco® Café Barriers create the perfect space for your customers and brand. Available in polished Stainless Steel or Satin Black.



Stainless Steel showing lower cross rail and sliding ring tether option.

Cross Rail Option
Instruction Video



Bungee Option
Instruction Video



- Premium 3 series polished stainless steel for optimum outdoor life and scratch resistance or tough satin black pole and base for an alternative look.
- 13.5kg x 360mm diameter base provides excellent stability.
- Rubber edged base prevents damage to floors and gives the option to roll rather than lift.
- Option of bottom cross rail for full Equality Act compliance or lower cost bungee tether.
- Flat packed for easy storage and transport.
- Easy to assemble. Spanner included.
- Stainless steel cross rails.
- Choice of banner sizes and materials.

Satin black pole.



Lower cost LT Base and Pole.

- Lower cost and lower performance hardware option.
- 2 series polished stainless steel pole and base.
- Lighter 10.3kg x 360mm diameter base.
- Bottom bungee tether option only.
- Easy to assemble. Spanner included.
- Same choice of high quality banners.

Unique features of Adfresco® Café Barrier:

Designed for easy end of life recycling.



Top/Clip

- Sleek top designed for comfortable lifting, comes with quick release cross rails.
- Supplied with a protective cover to prevent damage in transit.



Adfresco® Sliding Ring

- Unique patented smooth-glide ring allows banner to flex and eliminates wind damage associated with traditional designs.
- Not available with LT.

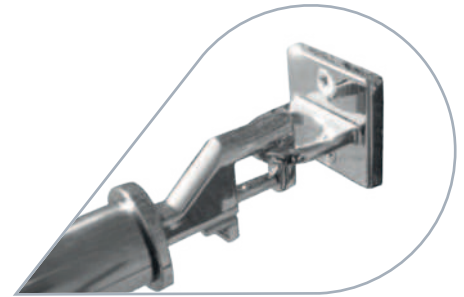

Chrome Plated Eye Plate

- For screw fixing to vertical wall or raised planter.



Adfresco® Base

- Concrete filled 13.5kg rubber edged base provides optimum stability, prevents damage to floors and gives the option to roll rather than lift.



Bottom Cross Rail

- Optional rigid lower cross rail provides audible tap for visually impaired (Equality Act Compliant).
- Not available with LT.



Bungee
Wall Hook

Bungee Connector

- Optional lower bungee connector holds banner taut – a cost effective alternative to a bottom cross rail.
- Prevents over stretching of banner.



Recyclable: stainless steel stanchion, base covers, stainless steel cross bars

Adfresco® Café Barrier - Selection Tool

Adfresco® allows you to individually select the elements to create your perfect Café Barrier - all with market leading features and benefits.

Choose your poles & bases:

Premium Adfresco® Stainless steel



Optimum outdoor life and scratch resistance.

Premium Adfresco® satin black



A popular alternative to Stainless steel.

Budget Adfresco® LT Stainless steel



Reduced specification. Stainless steel and lower bungee tether only.

OR

OR

Choose your lower tethering method:

Double cross-rail option

Provides strength, tautness and Equality Act compliance.

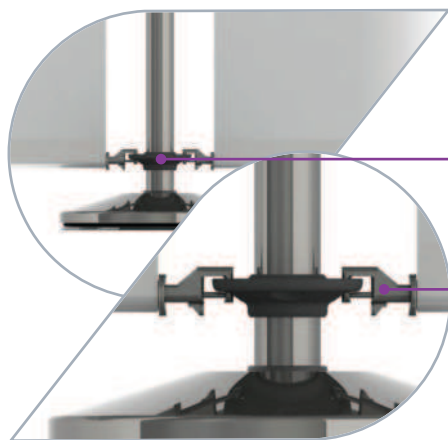

Sliding ring

Lower cross rail & clip

OR

Single cross rail and lower bungee option

Select the bungee pole connector and bungees instead of a second cross rail.

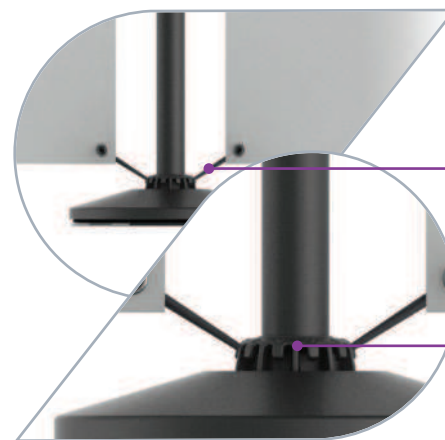

Bungee

Bungee connector

Choose your banner width:

For more exposed locations, such as seafront cafés, shorter banner widths work best.

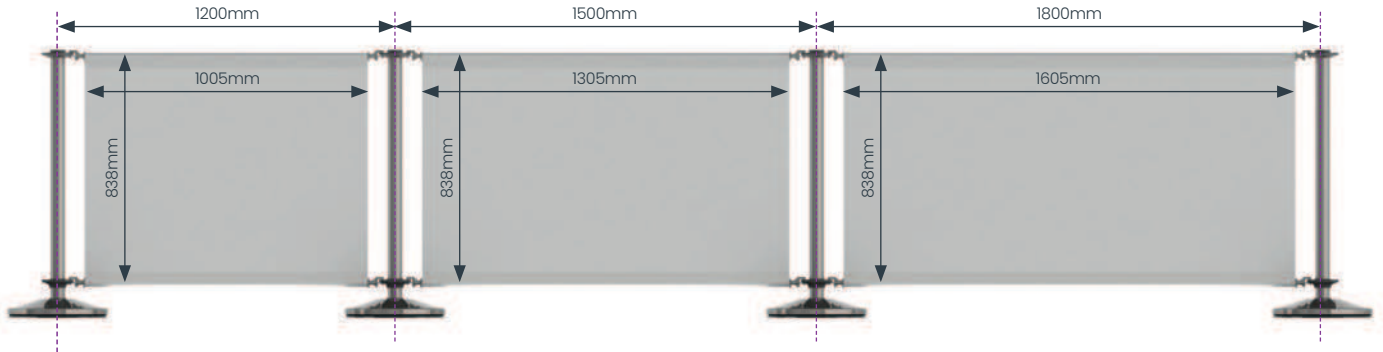

Choose your banner material:

Light Block PVC 750gsm

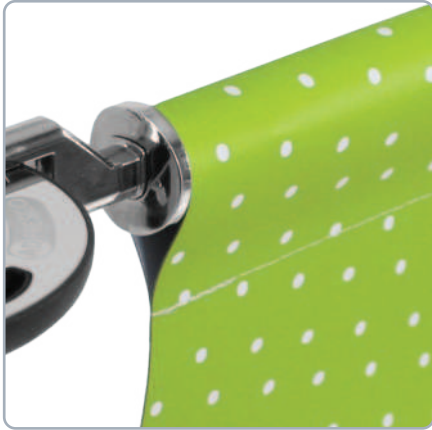

Reinforced and totally opaque, this is perfect for double sided print, long outdoor life and vibrant colour reproduction. The easy wipe clean surface makes it ideal for front of house food and drink environments.

Polyester Canvas 300gsm



This close weave 100% polyester fabric has all the appearance, weight and feel of a traditional canvas yet, unlike cotton based canvases, it is cost effective and will not rot or stain. Available full colour printed to one side with the option of white (unprinted) or single colour on the reverse.

Mesh PVC 380gsm

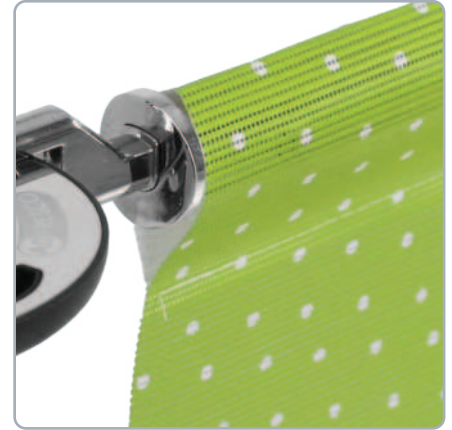

Provides a semi transparent finish and allows some air to pass through making it ideal for windy locations & subtle branding. Full colour print is available on one side (white on reverse).

All of our banners are suitable for outdoor use. To maintain best appearance, occasionally sponge down with warm soapy water. Use ratio: 30ml liquid soap / 10 litres water.

Adfresco® Café Barrier Kits

Premium Stainless Steel with Bungee Lower Tether.

Available with a choice of banner materials, see page 67 for more information.



Kit 1	Pole-to-pole width	Hardware Order Code
	1200mm	ASSI200K1BUNG
	1500mm	ASSI500K1BUNG
	1800mm	ASSI800K1BUNG



Kit 2	Pole-to-pole width	Hardware Order Code
	1200mm	ASSI200K2BUNG
	1500mm	ASSI500K2BUNG
	1800mm	ASSI800K2BUNG



Kit 3	Pole-to-pole width	Hardware Order Code
	1200mm	ASSI200K3BUNG
	1500mm	ASSI500K3BUNG
	1800mm	ASSI800K3BUNG



Kit 4	Pole-to-pole width	Hardware Order Code
	1200mm	ASSI200K4BUNG
	1500mm	ASSI500K4BUNG
	1800mm	ASSI800K4BUNG



Kit 5	Pole-to-pole width	Hardware Order Code
	1200mm	ASSI200K5BUNG
	1500mm	ASSI500K5BUNG
	1800mm	ASSI800K5BUNG

Adfresco® Café Barrier Kits

Premium Satin Black with Bungee Lower Tether.

Available with a choice of banner materials, see page 67 for more information.



Kit 1	Pole-to-pole width	Hardware Order Code
	1200mm	ASBI200K1BUNG
	1500mm	ASBI500K1BUNG
	1800mm	ASBI800K1BUNG



Kit 2	Pole-to-pole width	Hardware Order Code
	1200mm	ASBI200K2BUNG
	1500mm	ASBI500K2BUNG
	1800mm	ASBI800K2BUNG



Kit 3	Pole-to-pole width	Hardware Order Code
	1200mm	ASBI200K3BUNG
	1500mm	ASBI500K3BUNG
	1800mm	ASBI800K3BUNG



Kit 4	Pole-to-pole width	Hardware Order Code
	1200mm	ASBI200K4BUNG
	1500mm	ASBI500K4BUNG
	1800mm	ASBI800K4BUNG



Kit 5	Pole-to-pole width	Hardware Order Code
	1200mm	ASBI200K5BUNG
	1500mm	ASBI500K5BUNG
	1800mm	ASBI800K5BUNG

Adfresco® Café Barrier Kits

Budget LT Stainless Steel with Bungee Lower Tether.

Available with a choice of banner materials, see page 67 for more information.



Kit 1	Pole-to-pole width	Hardware Order Code
	1200mm	ALTI200K1
	1500mm	ALTI500K1
	1800mm	ALTI800K1



Kit 2	Pole-to-pole width	Hardware Order Code
	1200mm	ALTI200K2
	1500mm	ALTI500K2
	1800mm	ALTI800K2



Kit 3	Pole-to-pole width	Hardware Order Code
	1200mm	ALTI200K3
	1500mm	ALTI500K3
	1800mm	ALTI800K3



Kit 4	Pole-to-pole width	Hardware Order Code
	1200mm	ALTI200K4
	1500mm	ALTI500K4
	1800mm	ALTI800K4



Kit 5	Pole-to-pole width	Hardware Order Code
	1200mm	ALTI200K5
	1500mm	ALTI500K5
	1800mm	ALTI800K5

Adfresco® Café Barrier Kits

Premium Stainless Steel with Cross Rail Lower Tether.

Available with a choice of banner materials, see page 67 for more information.



Kit 1	Pole-to-pole width	Hardware Order Code
	1200mm	ASSI200K1CROSS
	1500mm	ASSI500K1CROSS
	1800mm	ASSI800K1CROSS



Kit 2	Pole-to-pole width	Hardware Order Code
	1200mm	ASSI200K2CROSS
	1500mm	ASSI500K2CROSS
	1800mm	ASSI800K2CROSS



Kit 3	Pole-to-pole width	Hardware Order Code
	1200mm	ASSI200K3CROSS
	1500mm	ASSI500K3CROSS
	1800mm	ASSI800K3CROSS



Kit 4	Pole-to-pole width	Hardware Order Code
	1200mm	ASSI200K4CROSS
	1500mm	ASSI500K4CROSS
	1800mm	ASSI800K4CROSS



Kit 5	Pole-to-pole width	Hardware Order Code
	1200mm	ASSI200K5CROSS
	1500mm	ASSI500K5CROSS
	1800mm	ASSI800K5CROSS

Adfresco® Café Barrier Kits

Premium Satin Black with Cross Rail Lower Tether.

Available with a choice of banner materials, see page 67 for more information.



Kit 1	Pole-to-pole width	Hardware Order Code
	1200mm	ASBI200K1CROSS
	1500mm	ASBI500K1CROSS
	1800mm	ASBI800K1CROSS



Kit 2	Pole-to-pole width	Hardware Order Code
	1200mm	ASBI200K2CROSS
	1500mm	ASBI500K2CROSS
	1800mm	ASBI800K2CROSS



Kit 3	Pole-to-pole width	Hardware Order Code
	1200mm	ASBI200K3CROSS
	1500mm	ASBI500K3CROSS
	1800mm	ASBI800K3CROSS



Kit 4	Pole-to-pole width	Hardware Order Code
	1200mm	ASBI200K4CROSS
	1500mm	ASBI500K4CROSS
	1800mm	ASBI800K4CROSS



Kit 5	Pole-to-pole width	Hardware Order Code
	1200mm	ASBI200K5CROSS
	1500mm	ASBI500K5CROSS
	1800mm	ASBI800K5CROSS

Adfresco® Example Layout

1. 12 poles/bases & 10 cross rails.

2. 10 poles/bases, 2 wall hooks/eye plates & 10 cross rails.

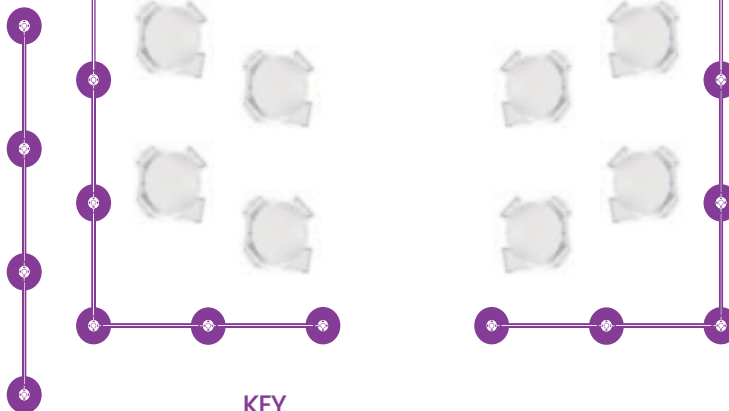
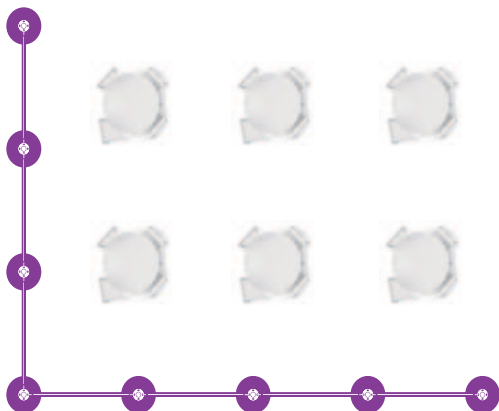

KEY



Adfresco® Base & Pole



Adfresco® Cross Rail & Banner

Choose your Adfresco® hardware:

Item	Dimensions (mm)	Weight (kg)	Order Code
Premium Stainless Steel Pole and Top Ring	Diameter: 113 (Pole Dia. 51mm) Height: 881	1.0	CBBPOLE-SS
Premium Black Steel Pole and Top Ring	Diameter: 113 (Pole Dia. 51mm) Height: 881	1.5	CBBPOLE-BLK
Budget LT Stainless Steel Pole and Top Ring	Diameter: 100 (Pole Dia. 51mm) Height: 881	1.0	CBBPOLE-201
Premium Stainless Steel Base	Diameter: 360 Height: 66	13.5	CBBBASE-SS
Premium Black Base	Diameter: 360 Height: 66	13.5	CBBBASE-BLK
Budget LT Stainless Steel Base	Diameter: 360 Height: 45	10.3	CBBBASE-201
Cross Rail (width refers to distance between pole centres)	Width: 1200	0.8	CBBCLIP-2 + CBBCROSSBAR-2
	Width: 1500	1.1	CBBBARI500-2 + CBBCROSSBAR-2
	Width: 1800	1.2	CBBBARI800-2 + CBBCROSSBAR-2
Sliding Ring	Diameter: 110 Height: 30	0.3	CBBRING
Bungee Pole Connector	Diameter: 94 Height: 26	0.1	CBBBUNGCON
Bungee	Overall length: 100	0.01	CBBBUNGEE2
Eye Plate	40 x 40 x 35 (w x h x d)	0.06	CBBEYEPLATE
Bungee Wall Hook	Diameter: 40	0.06	CBBHOOKPLATE

Classic Garden Parasol

UK Design Registration No. 6083532

The introduction of our Classic Garden Parasol, sometimes referred to as a Pub Parasol or Beach Umbrella, marked a return of the famous Hoyland Fox brand to the UK market, a name reflecting over 175 years of dedication to the manufacture of high quality umbrella frames.



Tough, rot and waterproof polyester fabric canopy.

Telescopic 22/25mm diameter steel pole with simple cam-clamp lever to adjust height.



Top finial.

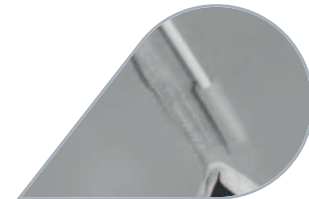

Rib tip retainer, stitching detail and valance hem.

No moving steel or metal parts – free of corrosion risk and moving parts not functioning properly.



Cam-clamp lever.



Ergonomic runner hub and release button.

Optional 20 litre white water-fillable base.



Ball and socket joint for 360 degree tilt direction – position the canopy to suit any sun angle without having to rotate the whole parasol.



Slider revealing ball and socket joint.

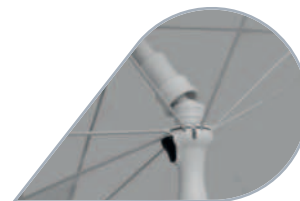

360 degree tilt direction.

Combined with a high specification canopy fabric and our printing expertise, the result is a unique parasol product that raises the bar in terms of quality and value for money.

- 1.8m (max open) diameter, 8k (8 rib) steel wire Hoyland Fox frame.
- 3.8mm diameter high tensile, hardened and tempered, carbon spring steel ribs and stretchers.
- Telescopic 22/25mm diameter steel pole with simple cam-clamp lever to adjust height.
- All steelwork zinc phosphate pre-treated before satin white polyester powder coating.
- Unique tilt feature offering shade wherever sun is angled.
- Sliding tilt protector (slider) locks canopy in horizontal position and stops unwanted tilting due to wind or tampering.
- 180gsm PA (acrylic) coated polyester fabric canopy – tough, rot and waterproof.
- Vibrant printing from single colour repeat logos to one full colour design covering the whole canopy – minimum 1 year outdoor life in UK.
- Optional 20 litre white PE water-fillable base – alternatively fill with kiln-dried sand for additional weight.

Product	Display Area (mm)	O/A Dimensions (w x h x d mm)	Weight (kg)	Order Code
Parasol Frame & Printed Canopy	Diameter: 1800mm	Max: 1800 x 2200 x 1800	2.6	PARAFRAME
Parasol Frame	Diameter: 1800mm	Max: 1800 x 2200 x 1800	1.9	PARAFRAME(ONLY)

Product	O/A Dimensions (w x h x d mm)	Weight (kg)			Order Code
		Empty	Water-filled	Sand-filled	
Parasol Base	440 x 150 x 440	126	18.5kg	29kg	PARABASE



Recyclable: steel telescopic pole, canopy support runners

Signtac® Self-Adhesive Floor Graphics

A professional range of certified, fire and slip-rated floor-graphic products to suit a variety of indoor and outdoor applications.



Range overview (see table opposite for full details and comparison):

Signtac® 6 Indoor (PVC)

- Short term (up to 6 months durability), indoor only.
- Specifically developed for simple tool-free installation.
- Clean and quick removal within 6 months.

Signtac® 6 Indoor (PET)

- Short term (up to 6 month durability), PVC free, indoor only.
- Easy to apply and dimensionally stable.
- Repositionable whilst installing.

Signtac® 12 Indoor

- 2-part laminated for longer term (up to 12 months), indoor only.
- Removable, non-damaging adhesive.
- Ideal for mid to heavy foot traffic areas.

Signtac® 12 Outdoor SS

- 2-part laminated for longer term (up to 12 months), outdoor or indoor.
- Aggressive adhesive suitable for low-energy surfaces and ideal for smooth concrete outdoors.

Signtac® 12 Outdoor RS

- Longer term (up to 12 months), outdoor.
- For coarse textured surfaces such as brick, concrete, asphalt, etc.
- Easy to apply, does not shrink and 100% recyclable.

Standard shapes and sizes:

Circles – 100mm, 200mm and 300mm dia.

Square – 100mm, 200mm and 300mm sq.

Triangles – 100mm, 200mm and 300mm sides.

Non-standard shapes and sizes:

Cut to shape within standard poster sizes A4, A3, A2, A1 and A0 and within 100/200/300mm squares.

Note – for optimum adhesion and safety, sharp corners and intricate cut detail in designs should be avoided.

		Indoor			Indoor & Outdoor	
		One Part	One Part	Two Part (laminated)	Two Part (laminated)	One Part
Product		Sigtac® 6 Indoor (PVC)	Sigtac® 6 Indoor (PET)	Sigtac® 12 Indoor	Sigtac® 12 Outdoor SS	Sigtac® 12 Outdoor RS
Description		200mic monomeric PVC film	170mic PET film	Vinyl: 90mic white monomeric PVC Laminate: 100mic matt pebble textured monomeric PVC	Vinyl: 80mic white polymeric PVC Laminate: 100mic matt pebble textured monomeric PVC	250mic white aluminium film
		Fire and slip-rated floor graphics for public spaces	Fire and slip-rated PVC-free floor graphic material	Slip-rated combination designed for floor graphic use on a variety of surfaces	Fire and slip-rated combination designed for floor graphic use on a variety of smooth outdoor surfaces	Fire and slip-rated floor graphic engineered for coarse textured outdoor floor surfaces
Applications		Indoor carpets (low pile), indoor tiles, indoor hardwood, sealed concrete, sealed wood, waxed vinyl, marble, terrazzo			Indoor/outdoor smooth concrete, brick and marble.	Outdoor tarmac, stone, ceramic tiles, paving slabs, indoor/outdoor concrete, brick
Adhesive		Removable	Removable	Removable	Permanent	Permanent
Slip Ratings	Pendulum Test Method	Low slip potential 40 PTV	Low slip potential 38 PTV	Low slip potential 36 PTV	Low slip potential 36 PTV	Low slip potential 72 PTV
	Ramp Test	R10	R10	R11	R11	R12
Fire Ratings		B1	Bfl – s1	Fire ratings not available	Combined Bfl – s1	Bfl – s1
Durability Dependent upon proper installation and foot traffic.		Short term up to 6 months indoor	Short term up to 6 months indoor	Long term up to 12 months indoor	Long term up to 12 months outdoor	Long term up to 12 months outdoor



Outdoor Wall/Window Mounted

We have some excellent secondary signage, chalkboard and poster display solutions available for wall or window mounting with weather resistant properties suitable for outdoor use.

Projecting 'flag' or 'bus-stop' advertising, to attract attention at eye-level and above, is available in the form of permanent projecting Flange Signs, or, as more temporary wall or window-mounted Display Flags that can be taken in at night or when the premises are closed. They are designed to provide elevated visibility and are a good alternative to a pavement sign when there isn't space on the pavement, or of course to complement a pavement sign that is designed to catch the eye at street level.

Our Poster Frames, Noticeboards and Menu Cases range includes low voltage LED illuminated options. It also includes a world beating range of Snapframes, the widely popular front opening aluminium poster frame that wins on price and functionality. As significant developers and manufacturers of the Snapframe since our first frame designs in 1990 we have been instrumental in bringing refinement, value engineering and supplementary patented innovation to the market ever since.

Dealer/Stockist Signs

Permanent brand presence at dealers and stockists.



When it comes to standing out at the point of purchase the combination of material choice, shape and printing effects can make a real difference.



Optional stand-off sign fixings.

Permanent brand signage at a stockist or dealers premises is a win-win, free advertising for the brand whilst the 'premium' brand endorsement will draw customers to the stockist. Long lasting, bold, vibrant print is the order of the day and that's our business!

- Premium options in aluminium, acrylic, polycarbonate or ACM.
- Screen print option and/or varnish over-print for extended outdoor life.
- Can be any size or shape pre-drilled for wall fixing.
- Stand-off fixing option for added prestige.
- Low-cost shorter outdoor life options in foam PVC or polypropylene ('Correx') - ideal for estate agent boards.



Recyclable: panel material dependant

Flavour/Range Boards



Flexible magnetic graphics, easy to interchange.

- Printed steel wall panel with set of interchangeable magnetic range labels (wall panel minimum order quantity 10).
- High promotional and functional value at the point of sale.
- Replacement magnetic labels can be purchased separately at a later date if required.



Recyclable: printed steel back panel



Snapframes (overview)

 Fully Recyclable



Anti-glare cover sheet included.



All our Snapframes feature:

- Easy snap-open/snap-shut poster change.
- Built-in security – when closed all fixings and opening method are hidden from view.
- UV stable poster cover sheet – will not turn brown and protects poster from fade in sunlight.
- Anti-glare poster cover sheet – maintains message visibility under bright lighting.
- Pre-drilled and individually boxed with screws and wall plugs.
- We recommend the use of moisture resistant posters when used outdoors (see page 192).

Note: wider frame profiles do a better job of keeping the poster cover and poster secure in windy weather than smaller frame profiles.

Made to order service from a choice of 12 stock finishes

- Fast lead times – typically, 1-10 frames (3-5 days), 11-25 frames (5-7 days).
- Custom sizes from as small as 210 x 210mm.
- Oversize frames (>1.5m²) may require collecting by customer if too large for our parcel delivery provider or for palletising.
- Choose from the following stock colours and finishes:



Silver anodised (stocked)
15, 25 or 38mm standard and 25mm or 42mm security.



RAL 9003 Signal White*
(25 & 38mm)



RAL 9005 Jet Black*
(25 & 38mm)



RAL 7037 Dusty Grey
(25 & 38mm)

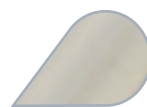

Satin Chrome
(25mm)



Stainless Steel
(25mm only)



RAL 6005 Moss Green
(25 & 38mm)

* Standard sizes stocked – see pages 83-86.

Other colours available subject to minimum order quantity and longer lead time.



RAL 3020 Traffic Red
(25 & 38mm)



RAL 5002 Ultramarine Blue
(25 & 38mm)



Sapphire Blue
RAL 5003
(25 & 38mm)

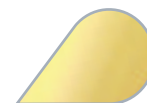

Gold
(25mm only)



Wood
(25mm only)

Standard Snapframes

Quick and easy poster display for indoor and outdoor use.



15mm Profile with Mitred Corners – Silver

Poster Size	Display Area (mm)	O/A Dimensions (w x h mm)	Weight (kg)	Order Code
A5	130 x 190	160 x 220	0.16	SNA515SA(P)
A4	195 x 280	225 x 310	0.23	SNA415SA(P)
A3	277 x 400	307 x 430	0.34	SNA315SA(P)

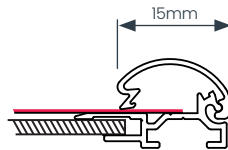

15mm Profile with Mitred Corners – Black

Poster Size	Display Area (mm)	O/A Dimensions (w x h mm)	Weight (kg)	Order Code
A5	127 x 188	158 x 220	0.16	SNA515BLK(P)



25mm Profile with Round Corners – Silver

Poster Size	Display Area (mm)	O/A Dimensions (w x h mm)	Weight (kg)	Order Code
A4	195 x 282	245 x 333	0.28	SNRA425SA(P)
A3	275 x 400	325 x 450	0.44	SNRA325SA(P)
A2	405 x 580	455 x 630	0.70	SNRA225SA(P)
20" x 30"	492 x 745	545 x 797	0.96	SNR2325SA(P)
A1	574 x 821	624 x 870	1.3	SNRA125SA(P)

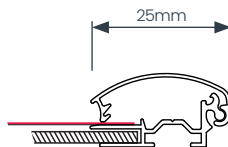

Standard Snapframes

Quick and easy poster display for indoor and outdoor use.



25mm Profile with Mitred Corners - Silver

Poster Size	Display Area (mm)	O/A Dimensions (w x h mm)	Weight (kg)	Order Code
A4	190 x 277	240 x 325	0.28	SNA425SA(P)
A3	275 x 399	327 x 448	0.44	SNA325SA(P)
A2	400 x 575	450 x 625	0.71	SNA225SA(P)
495 x 708mm	477 x 690	528 x 740	0.80	SN49570825SA(W)
20" x 30"	492 x 746	544 x 797	0.97	SN2325SA(P)
A1	576 x 825	627 x 875	1.0	SNA125SA(P)
A0	824 x 1172	876 x 1222	1.74	SNA025SA(W)

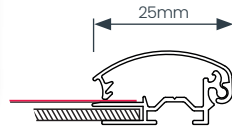

25mm Profile with Mitred Corners - Black

Poster Size	Display Area (mm)	O/A Dimensions (w x h mm)	Weight (kg)	Order Code
A4	190 x 277	240 x 325	0.28	SNA425BLK(P)
A3	275 x 399	327 x 448	0.44	SNA325BLK(P)
A2	400 x 575	450 x 625	0.71	SNA225BLK(P)
20" x 30"	492 x 746	544 x 797	0.97	SN2325BLK(P)
A1	576 x 825	627 x 875	1.0	SNA125BLK(P)
A0	821 x 1169	875 x 1223	1.87	SNA025BLK(W)

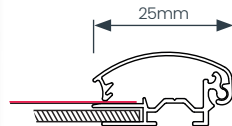

Standard Snapframes

Quick and easy poster display for indoor and outdoor use.

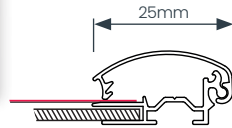

25mm Profile with Mitred Corners - White

Poster Size	Display Area (mm)	O/A Dimensions (w x h mm)	Weight (kg)	Order Code
A4	190 x 277	240 x 325	0.28	SNA425WT(P)
A3	275 x 399	327 x 448	0.44	SNA325WT(P)
A2	400 x 575	450 x 625	0.71	SNA225WT(P)
20" x 30"	492 x 746	544 x 797	0.97	SN2325WT(P)
A1	576 x 825	627 x 875	1.0	SNA125WT(P)



25mm Profile with Mitred Corners - Traffic Red (RAL 3020)

Poster Size	Display Area (mm)	O/A Dimensions (w x h mm)	Weight (kg)	Order Code
A4	190 x 277	240 x 325	0.28	SNA425RD(P)
A3	275 x 399	327 x 448	0.44	SNA325RD(P)



25mm Profile with Mitred Corners - Ultramarine Blue (RAL 5002)

Poster Size	Display Area (mm)	O/A Dimensions (w x h mm)	Weight (kg)	Order Code
A4	190 x 277	240 x 325	0.28	SNA425BLU(P)
A3	275 x 399	327 x 448	0.44	SNA325BLU(P)

Standard Snapframes

Quick and easy poster display for indoor and outdoor use.

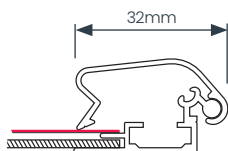

32mm Profile with Mitred Corners – Silver

Poster Size	Display Area (mm)	O/A Dimensions (w x h mm)	Weight (kg)	Order Code
A4	190 x 280	255 x 340	0.47	SNA432SA(W)
A3	275 x 400	340 x 465	0.67	SNA332SA(W)
A2	400 x 575	465 x 640	0.96	SNA232SA(W)
20" x 30"	490 x 745	550 x 805	1.22	SN203032SA(W)
A1	575 x 820	635 x 885	1.45	SNA132SA(W)
30" x 40"	740 x 995	805 x 1060	2.0	SN304032SA(W)
A0	820 x 1170	880 x 1230	2.5	SNA032SA(W)
40" x 60"	995 x 1505	1055 x 1565	3.0	SN406032SA(W)

Also available with round corners (made to order).

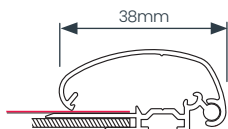

38mm Profile with Mitred Corners – Silver

Poster Size	Display Area (mm)	O/A Dimensions (w x h mm)	Weight (kg)	Order Code
30" x 40"	725 x 980	800 x 1050	2.0	SN3438SA(W)
A0	805 x 1154	888 x 1230	2.5	SNA038SA(W)
40" x 60"	980 x 1490	1060 x 1570	3.5	SN4638SA(W)

Security Snapframes

Virtually impossible to open by hand.



A4 shown

- Easily opened by our hand-held opening tool (sold separately, order code: SFS0T01).
- Available in 2 profile sizes (25mm and 42mm).
- Supplied with anti-glare poster cover sheet for clear poster display.
- Pre-drilled and individually boxed with screws and wall plugs.
- Increased frame tension in Security frames can offer improved resistance to poster cover loss in windy situations.
- Silver anodised finish as standard. 25mm profile custom colour frames available made to order.
- Custom sizes available made to order.
- Ideal for schools, colleges and spaces at risk of unwanted tampering.
- We recommend the use of moisture resistant posters when used outdoors (see page 192).

25mm Profile with Mitred Corners

Poster Size	Display Area (mm)	O/A Dimensions (w x h mm)	Weight (kg)	Order Code
A4	195 x 282	245 x 332	0.34	SNSA425SA(W)
A3	282 x 405	332 x 450	0.5	SNSA325SA(W)
A2	405 x 578	455 x 630	0.75	SNSA225SA(W)
20" x 30"	493 x 745	543 x 796	1.0	SNS2325SA(W)
A1	577 x 825	628 x 875	1.2	SNSA125SA(W)

42mm Profile with Mitred Corners

Poster Size	Display Area (mm)	O/A Dimensions (w x h mm)	Weight (kg)	Order Code
30" x 40"	722 x 977	807 x 1065	3.5	SNS3442SA
A0	800 x 1147	890 x 1230	4.0	SNSA042SA
40" x 60"	975 x 1482	1060 x 1565	6	SNS4642SA



Hand-held opening tool.



 Fully Recyclable

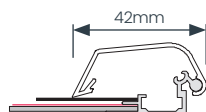

Lockable Snapframes

For optimum poster security.



- Opens via simple Allen Key operation (included).
- Sides open sequentially for added security.
- Ideal for unmonitored locations.
- 32mm profile silver anodised frame.
- Supplied with anti-glare poster cover sheet for clear poster display.
- Pre-drilled and individually boxed with screws and wall plugs.
- We recommend the use of moisture resistant posters when used outdoors (see page 192).

32mm Profile with Mitred Corners

Poster Size	Display Area (mm)	O/A Dimensions (w x h x d mm)	Weight (kg)	Order Code
A4	190 x 280	255 x 340	0.56	SNLKA432SA(W)
A3	280 x 402	345 x 465	0.75	SNLKA332SA(W)
A2	400 x 575	464 x 640	1.1	SNLKA232SA(W)
495 x 708	475 x 690	540 x 750	1.3	SNLK49570832SA(W)
20" x 30"	490 x 742	552 x 805	1.4	SNLK203032SA(W)
A1	575 x 822	640 x 885	1.62	SNLKA132SA(W)
30" x 40"	740 x 997	805 x 1058	2	SNLK304032SA(W)
A0	822 x 1170	885 x 1230	2.5	SNLKA032SA(W)
40" x 60"	1000 x 1505	1057 x 1565	3.5	SNLK406032SA(W)



Fully Recyclable



Easy to insert and change poster.



Opens via simple Allen key operation.

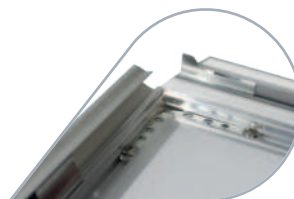

Sequentially closing sides.



Anti-glare cover sheet included.

Frameworkz

Patent No. 2464696

Unlike any other poster frames available, Frameworkz Snapframes can be digitally printed with almost any design. From logos and text to images and patterns, the choice is yours and the opportunities are truly endless.

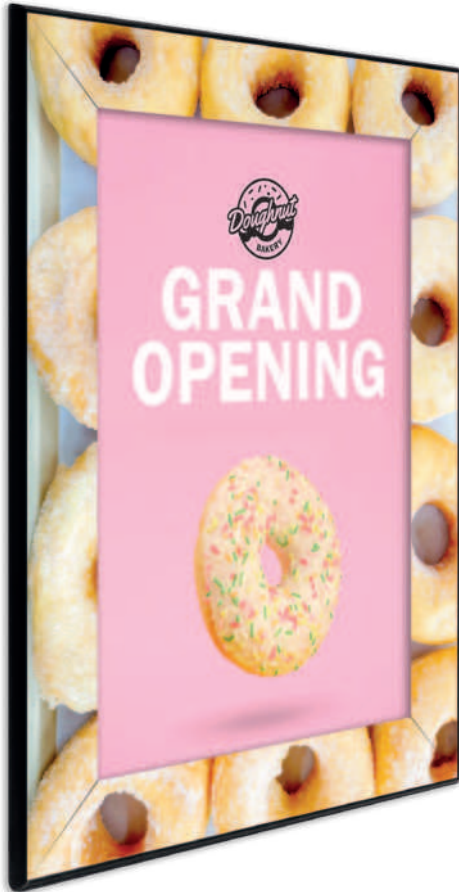

- Front opening aluminium snapframes for quick and easy poster change.
- Suitable for external use (2-3 years in temperate climate) and we recommend the use of moisture resistant posters (see page 192).
- Minimal distance between frame and poster allows design to cross over.
- Anti-glare 500 micron PET poster cover sheet as standard or optional 750 micron gloss clear polycarbonate at additional cost.
- Pre-drilled for wall mounting.
- Available in any frame size from A3 to 40" x 60".
- Made to order.



When closed, all fixings and opening method are hidden from view.

Flat 50mm wide print surface.

Stylish satin black border.

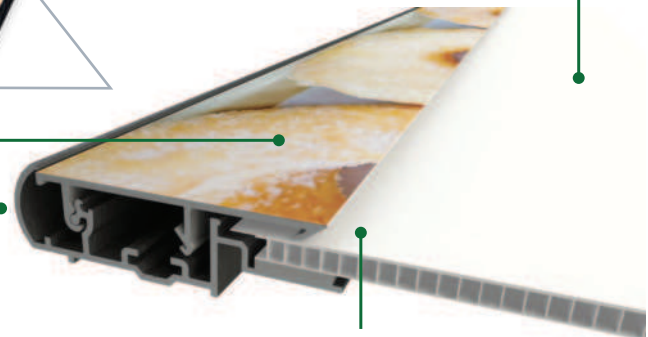

Minimal distance between frame and poster allows design to cross over.

 **Recyclable:** aluminium frames, PET poster cover sheet, mechanical fixings

Poster Size	Display Area (mm)	O/A Dimensions (w x h x d mm)	Profile Depth (mm)
Any size from A3 to 40" x 60"	Poster -31.5	Poster +79	15

Due to frame cutting and artwork tolerances of +/- 1mm, a visible step across the mitred corners is sometimes unavoidable. Designs featuring straight lines across the corners will be particularly prone to this.

Slimlok Poster Case

Stylish poster display cases with lockable doors.

Stock colours available
made to order:



- 52 x 30mm profile durable aluminium frame.
- Vandal resistant 1.5mm polycarbonate glazing panel.
- Internal clips hold posters securely in place and allows for quick and easy poster change.
- Ideal for outdoor use.
- Door stays supplied as standard on stock units at A1 size or larger.
- A1 size and larger have two locks.
- Custom sizes available with or without stays, made to order.



Key plus spare included.

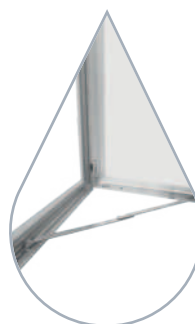

Door stays on larger sizes are standard.



Internal clips hold posters securely in place.



Recyclable: aluminium frames, polycarbonate glazing panel

Poster Size	Display Area (mm)	O/A Dimensions (w x h x d mm)	Weight (kg)	Order Code (without door stays)		Order Code (with door stays)	
				Silver	Black	Silver	Black
A4	186 x 273	291 x 378 x 32	2	SKA4MK3(W)	SKA4MK3BLK	-	-
A3	273 x 396	378 x 501 x 32	2.5	SKA3MK3(W)	SKA3MK3BLK	-	-
A2	396 x 570	501 x 675 x 32	3.5	SKA2MK3(W)	SKA2MK3BLK	-	-
20" x 30"	484 x 738	589 x 843 x 32	5	SK2030MK3(W)	SK2030MK3BLK	-	-
A1	570 x 817	675 x 922 x 32	6	-	-	SKA1MK3WS(W)	SKA1MK3WSBLK
30" x 40"	738 x 992	843 x 1097 x 32	8	-	-	SK3040MK3WS(W)	SK3040MK3WSBLK
A0	817 x 1165	922 x 1270 x 32	9	-	-	SKA0MK3WS(W)	SKA0MK3WSBLK(W)
40" x 60"	992 x 1500	1097 x 1605 x 32	13	-	-	SK4060MK3WS	SK4060MK3WSBLK

Slimlok Menu Case

Featuring a magnetic back panel and dedicated header area.

Stock colours available
made to order:



- 52 x 30mm profile durable silver anodised aluminium frame.
- Vandal resistant 1.5mm polycarbonate glazing panel.
- Supplied with a set of magnetic pins.
- Not designed for landscape orientation.
- Door stays fitted as standard on 4 x A4 model.
- Key plus spare included.
- Header branding in self adhesive vinyl or direct to surface print (no minimum order quantity).
- Custom sizes available made to order.



Available in 4 stock sizes



Recyclable: aluminium frames,
polycarbonate glazing panel,
steel back panel

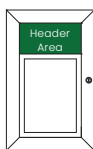

1 x A4

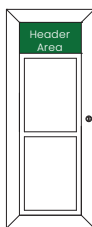

2 x A4
Vertical

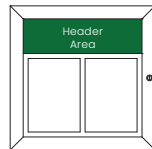

2 x A4
Horizontal

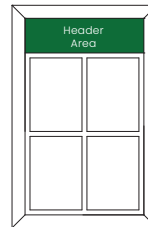

4 x A4*

O/A Dimensions (w x h x d mm)	355 x 567 x 32	355 x 884 x 32	585 x 585 x 32	585 x 899 x 32
Header Size (mm)	251 x 125	251 x 125	481 x 140	481 x 140
Approx. Weight (kg)	2.6	3.6	3.8	5.8
Order Code	SKMC1XA4MK3	SKMC2XA4VERTMK3	SKMC2XA4HORIMK3	SKMC4XA4MK3

*Door stays fitted as standard



Illuminated Slimlok Menu Case

Stylish 24 hour menu display with branded header area.



- 52 x 30mm durable silver anodised aluminium frame.
- Vandal resistant 1.5mm polycarbonate glazing panel.
- Magnetic pins included.
- Not designed for landscape orientation.
- Door stays fitted as standard on 4 x A4 model.
- Key plus spare included.
- Vinyl or direct to surface printed header branding available made to order.
- 2.5m power cable with 3-pin 12V plug adaptor included.

Stock colours available made to order:



Jet Black
RAL 9005



Signal White
RAL 9003



Dusty Grey
RAL 7037



Traffic Red
RAL 3020



Ultramarine
Blue RAL 5002



Sapphire Blue
RAL 5003



Moss Green
RAL 6005



LED strip along top inside edge.



3m waterproof extension cable (page 203).

Available in 4 stock sizes



Recyclable: aluminium frames, polycarbonate glazing panel, steel back panel

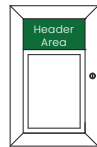

1 x A4

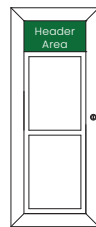

2 x A4
Vertical

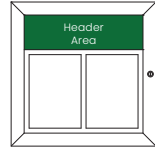

2 x A4
Horizontal

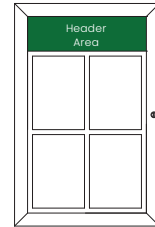

4 x A4*

O/A Dimensions (w x h x d mm)	355 x 567 x 32	355 x 884 x 32	585 x 585 x 32	585 x 899 x 32
Header Size (mm)	251 x 125	251 x 125	481 x 140	481 x 140
Approx. Weight (kg)	2.8	3.8	3.9	5.8
Order Code	SKILLMC1XA4MK3	SKILLMC2XA4VMK3	SKILLMC2XA4HMK3	SKILLMC4XA4MK3

* Door stays fitted as standard.

Slimlok Noticeboard

Stylish poster display case with lockable doors and magnetic back panel.

Stock colours available
made to order:



4x4 shown.

- 52 x 30mm profile durable silver anodised aluminium frame.
- Vandal resistant 1.5mm polycarbonate glazing panel.
- Magnetic pins included.
- Suitable for internal or external use, portrait or landscape.
- Back panel suitable for vinyl application.
- Door stays fitted as standard on all models.
- Custom sizes available made to order.
- Key plus spare included.



Supplied with a set of magnetic pins.

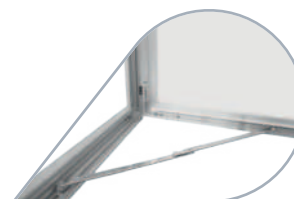

Door stays fitted as standard on all models.

Available in 4 stock sizes

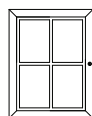

4 x A4

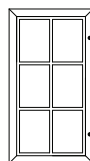

6 x A4

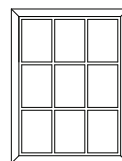

9 x A4

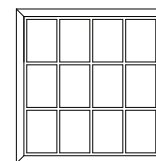

12 x A4



Recyclable: aluminium frames,
polycarbonate glazing panel,
steel back panel

O/A Dimensions (w x h x d mm)	585 x 759 x 32	585 x 1076 x 32	815 x 1076 x 32	1045 x 1076 x 32
Weight (kg)	6.4	8	12	14.8
Order Code	NB4XA4MK3	NB6XA4MK3	NB9XA4MK3	NB12XA4MK3



Lockable Weatherproof Smart LEDbox

Stylish low-profile illuminated poster frame for outdoor use.



- Front opening 35mm profile silver anodised snapframe for quick and easy poster change.
- Tamper-resistant locking frame with sequential opening (Allen key included).
- Weather seal for outdoor poster protection.
- Suitable for portrait or landscape wall mounting.
- Edgelit panel provides strong, even illumination.
- White Osram LEDs emitting 6500K optimum colour temperature.
- Swivel feature offers optional rear (hidden) or side cable exit point.
- Wall fixings and CE certificate supplied with each unit.
- We recommend the use of Printed Backlit Poster Films for lightbox poster inserts (see page 194).



2m power cable and power supply included.



2m internal and external (waterproof) extension cables available (page 203).

DAY

NIGHT



Recyclable: aluminium snapframe perimeter frame, PET poster cover, acrylic light panel

Poster Size	Display Area (mm)	O/A Dimensions (w x h x d mm)	Weight (kg)	Order Code
30" x 40"	753 x 1007	823 x 1077 x 30	13.25	EXTLED34
A0	832 x 1180	902 x 1250 x 30	15.42	EXTLEDA0
40" x 60"	1007 x 1515	1077 x 1585 x 30	24.37	EXTLED46



Teardrop Flying Banner (on Angled Wall Bracket)

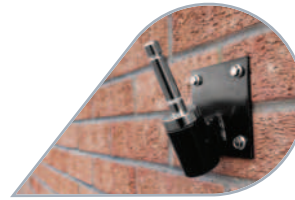

Permanent wall-mounted bracket.



Slide-on/slide-off pole fit.

A great way to pack a promotional punch at the store front if pavement or forecourt space is at a premium, or if you just want to do something different and impactful above head height.

- Small Teardrop Flying Banner in standard or airmesh polyester textile supported on a sectional carbon composite pole.
- 2m long flag and rotational movement for eye-catching long range outdoor promotion.
- Angled Bracket Mount Bearing Spindle offers friction-free flag rotation and secure flag retention, whilst being easy to detach the pole and flag when premises are closed.
- For additional product information see Flying Banners on page 50.

Item	Weight (kg)	Size (mm)	Order Code
Pole & Bag	1	-	FBTSM
Angled Bracket Mount Bearing Spindle	0.83	-	FB25DGWALBRG
Printed flag with wrap-around printed pole sleeve	-	771 x 2060	FBTSMBAN(SW)
Printed flag with reinforced elasticated black pole sleeve	-	800 x 1992	FBTSMBANBEH(SW)
Printed flag with reinforced elasticated white pole sleeve	-	800 x 1992	FBTSMBANWEH(SW)

For a printed air-mesh flag add 'A' to the end of the appropriate order code.

Hi-Sight

Registered Design No. 000879876

Instruction Video



Thanks to its unique pull down poster cartridge, the Hi-Sight has many advantages over traditional poster frames.



- Can be mounted up to 3 times higher than a regular frame.
- Poster change is quicker, easier and safer – no need to stretch or use ladders.
- Reduced risk of tampering and vandalism.
- Hard wearing aluminium frame.
- Fixed polycarbonate cover with magnetic seals, virtually no risk of poster loss.
- Excellent weather resistance.
- Custom sizes available made to order.
- Custom colour poster cover sheet borders available made to order.

Ideal for out of town retailers. Hi-Sight maximises visibility of store front promotions – vital in the drive for greater awareness and increased sales.

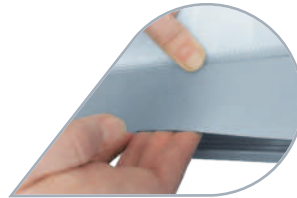

Apply finger pressure just above border and lift.



Poster cover security fixings.



Traditional frames – low visibility.



Hi-Sight – high visibility!

Pull down poster cartridge for safe, quick and easy poster change.

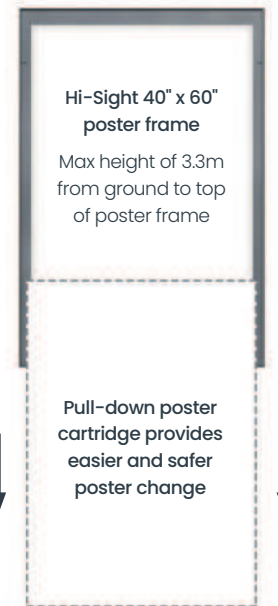
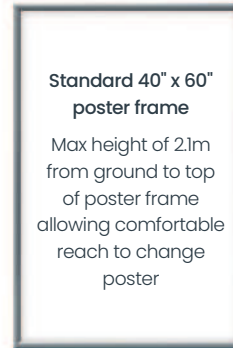

Posters are held in place by 4 pinch holders on the top of the cartridge.

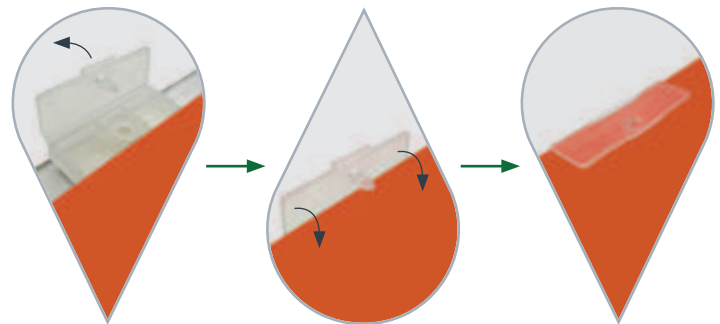

Open poster-pinch mounts to add or change posters.

Place poster within poster-pinch opening.

Close poster-pinch mounts to pierce and grip poster.



Recyclable: aluminium frames, polycarbonate poster cover

Poster Size	Display Area (mm)	O/A Dimensions (w x h x d mm)	Weight (kg)	Availability	Order Code
A0	830 x 1163	937 x 1295	8.4	Made to order	HISA0SA(S)
40" x 60"	1005 x 1498	1112 x 1630	12	Stocked	HIS46SA(S)

External Banner

Semi-permanent large format outdoor promotion.

- Any size up to 20m x 3m.
- Choice of 3 stock materials including a light-block for double-sided print.
- Folded welded hems provide a double strength perimeter for optimal wind load/tear resistance.
- Corrosion-free metal eyelets or durable clear recyclable plastic eyelets at our discretion.
- Supplied with 300mm translucent white nylon cable ties- extremely secure, quick and easy to use to achieve the best banner appearance.
- Individually poly-bagged for protection during distribution.
- See our Banner Frames opposite and on page 48.

 Made to order

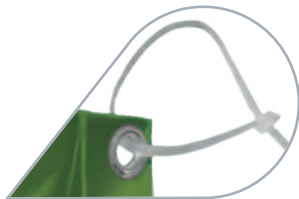

All banners supplied with tie-wraps.



Front-lit PVC 440gsm



Our most popular banner for single sided print only. Front-lit banners suit fence and wall-mounting locations.

Light Block PVC 510/610gsm



Our highest performing material, Light Block PVC provides excellent colour vibrancy and long lasting performance. Ideal for single or double sided print.

Mesh PVC 270/380gsm*



Perforations allow air to pass through and reduce wind loading, making it well-suited for windy locations eg. seafronts & site/event fencing.

*Subject to size/quantity.

Wall Banner Frame

Lightweight aluminium banner frame kit for wall mounting indoors or outside.



- 8x galvanised steel stand-off brackets for wall mounting.
- Aluminium 25 x 25mm frame tubes – low weight for handling and fitting.
- Fast push-fit assembly with simple installation.
- Low profile design – frame stands just 125mm forward of any mount surface.
- Self-adjusting bungee hooks hold eyeletted banners under tension.
- Bungees included.
- Recommended banner size: 2840 x 1090mm.
- Printed Banners available.



Wall fixing brackets.



Full bungee kit included.



Recyclable: aluminium tubes, wall brackets

Display Area (mm)	O/A Dimensions (w x h x d mm)	Weight (kg)	Order Code
2840 x 1090	3000 x 1250 x 125	5	BANFRAMEWALL

Standard Flag Kit

For wall mounting.



- Tapered socket ensures excellent pole grip and prevents loss of flags in windy conditions.
- Suitable for screw fixing to walls.
- Kit includes PVC pole and polypropylene finial, collar and wall bracket. Flag available separately.
- Plain 750gsm reinforced light-block PVC flags are a stocked product. Suitable for vinyl graphics.
- Marine grade polyester stitching for optimum flag life.
- Printed flags available.
- Custom shape flags available made to order (minimum order quantity 25).



Wall bracket.



Recyclable: polypropylene bracket, PVC pole, polypropylene collar and finial, PVC flag

Item	Dimensions (mm)	Weight (kg)	Order Code
Standard Flag Kit (bracket, pole, finial and collar)	Bracket: 50 (w) x 117 (h) Pole: 750 (length) x 19 (dia.)	0.2	FLKIT
Display Flag	430 x 355 x 560	0.2	FLAGTRADE



Noscrewz Flag Kit

Ideal for glass mounting.



Patent No. 2443417
Instruction Video



- Safe, tamper proof and secures on any smooth surface.
- Incredibly quick and easy to use, simply push onto surface and twist. No tools required.
- Kits include bracket, sectional pole offering variable length, collar and finial. Flag available separately.
- Suitable for internal and external use.
- Plain 750gsm reinforced light-block PVC flags are a stocked product. Suitable for vinyl graphics.
- Print service available.
- Custom shape flags* available made to order (minimum order quantity 25).



Elbow-adaptor included to allow flags to be angled.



A simple twist creates a vacuum that locks the bracket in place.



Simply twist back and pull upper or lower tab to release bracket.

   **Recyclable:** PVC/ASA bracket, PVC pole, polypropylene collar and finial, PVC flag

* Care is required if using Noscrewz for oversized (wider and/or taller) flags. Unless the pole is shortened (use of fewer pole sections during assembly) we would only recommend flags in our standard 750gsm reinforced light block PVC up to a maximum of 0.25m² (less than 200g in weight).

Item	Dimensions (mm)	Weight (kg)	Order Code
Noscrewz Flag Kit (bracket, pole, finial and collar)	Bracket: 90 (w) x 150 (h) Pole length: 150/300/450/600/750 Pole diameter: 19	0.4	NOSCREWZ2
Display Flag	430 x 355 x 560	0.2	FLAGTRADE

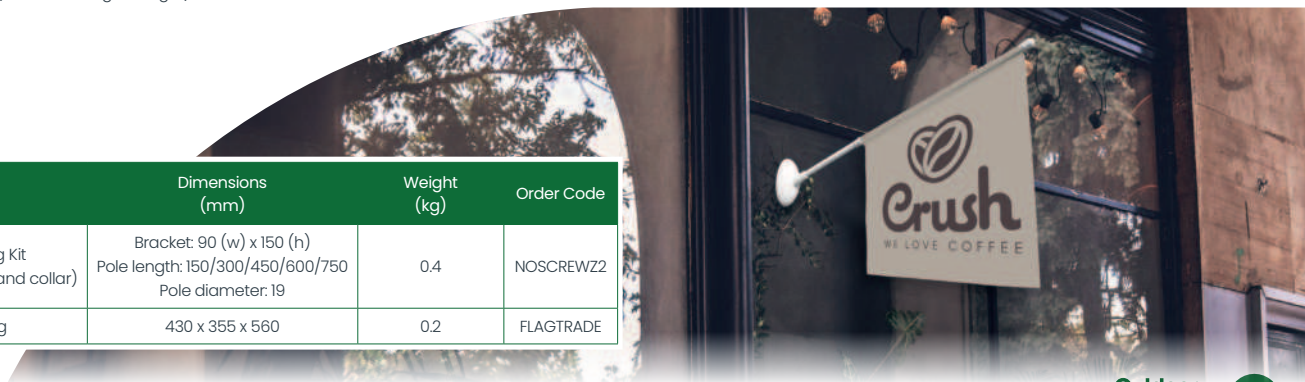

Flange Signs

Low cost, high impact flat projecting signs, available in 3 standard sizes.

Standard shapes/sizes:

Rectangular



Round



Oval



Fully Recyclable

Shape	Display Area (w x h mm)	O/A Dimensions (w x h x d mm)	Weight (kg)	Order Code
Round	495 diameter	550 x 495 x 50	0.83	FLSR1.2
Oval	500 x 400	600 x 400 x 50	0.72	FLSO1.2
Rectangular	575 x 417	575 x 417 x 50	0.91	FLSS1.2

- Cost effective, double sided shop front advertising.
- Exceptional value with 5 plus years of outdoor life.
- 1.2mm aircraft grade aluminium panels with a gloss white polyester powder coated finish – ideal for vinyl application.
- Direct to surface printing available. No minimum order quantity.
- 50mm fixing flange, pre-drilled with round fixing holes as standard.

Custom shapes/sizes:



- Customised shape can enhance stand-out and brand recognition.
- Custom shapes and sizes available made to order (minimum order quantity 25).



Made to order

Chalkboards (Framed)

Reversible certified timber-framed chalkboards manufactured in our Woodworkz® production facility.



- Woodworkz® joinery quality for a long maintenance-free life.
- 3 stock sizes in 'Country Oak' finish.
- For wall mounting, suspending or lean-to floor standing – fixing kit included.
- Hard-wearing panel surface for traditional chalk or liquid chalk pens.
- Exterior grade 6mm thick chalk-face laminated MDF panel in a 45 x 21mm timber frame stained and lacquered for optimum outdoor protection.
- Single or double-sided print available (minimum order quantity 10).
- Custom colour frames and sizes available made to order (minimum order quantity 20).



Fully Recyclable

Display Area (mm)	O/A Dimensions (w x h x d mm)	Weight (kg)	Order Code
370 x 573	460 x 663 x 21	2.4	CFCO460X663EX
573 x 773	663 x 863 x 21	4.2	CFCO663X863EX
703 x 1073	793 x 1163 x 21	6.4	CFCO793X1163EX

Wall Chalkboards (Unframed)

Premium high pressure laminate (HPL) chalkboards for indoor or outdoor use.



Display Area (mm)	Dimensions (w x h x d mm)	Weight (kg)	Order Code
206 x 293	210 x 297 x 3	0.3	CWB210X297
294 x 396	298 x 400 x 3	0.5	CWB298X400
396 x 594	400 x 600 x 3	1.1	CWB400X600
594 x 796	600 x 800 x 3	2.2	CWB600X800
796 x 1196	800 x 1200 x 3	4.4	CWB800X1200



Pre-drilled in each corner with 5.5mm dia. hole.

- 3mm thick maintenance-free HPL.
- 5 stock sizes pre-drilled for wall mounting (fixings not included).
- Hard wearing chalkboard surface both sides.
- Solid black material/black edges.
- Easy to clean with a damp cloth (traditional chalk) or household cleaner (Liquid Chalk Pens - see page 105).
- Single or double-sided printing available.
- Custom sizes and shapes, with or without holes, available made to order.
- Alternative 2mm thickness available made to order.
- 'Greenguard' Indoor Air Quality Certified for safe environmental use in schools.

Note – our 6mm melamine faced MDF Easel Chalkboards (see page 113) offer a lower cost option for indoor wall mounting.



Custom sizes/shapes made to order.



Messaging is easy with our Liquid Chalk Pens... (see page 105)



...and easy to remove with commonly available household cleaner.

Our Chalkboard Panels



The last thing customers want is a chalkboard that requires repainting regularly and warps and disintegrates if used outdoors. Sadly there are too many inferior products on the market that do just that – even when advertised for outdoor use!

Our high-quality board materials:

- Are maintenance-free and never need repainting.
- Are easy to clean with water and household cleaner.
- Have a weather and scratch resistant anti-glare surface.
- Are suitable for use with traditional chalk or Liquid Chalk Pens.
- Can be direct to surface printed.

The specially formulated melamine surface on our premium laminate materials means your chalkboards stay looking new for longer.



Liquid Chalk Pens

- Pens are rainproof after just 1 hour yet erasable with a damp cloth.
- **Top tip** – Mr Muscle for windows is an excellent chalkpen cleaner.
- Assorted pack contains: red, green, white, yellow and blue.
- Superior colour vibrancy and outdoor durability shown from our independent outdoor tests.

Nib Size (mm)	Pack Quantity	Colour(s)	Order Code
5 (small)	5	Assorted	CHALKPENSET1
15 (large)	3	White	CHALKPENSET2
15 (large)	5	Assorted	CHALKPENSET3



Exterior Leaflet Holders

Round-the-clock promotion, whatever the weather.



- Made from hard-wearing, crystal clear polystyrene with UV inhibitor for outdoor performance.
- Self closing lid ensures holder can never be left open and protects literature inside.
- Lid features integrated "please take one" message.
- Ventilation holes on underside minimise condensation.
- Keyhole slots on rear for screw fixing to walls.



Self-closing acrylic lid.



Integrated message.

Available in 3 stock sizes



Size	1/3 A4 portrait (DL)	A5 portrait	A4 portrait
O/A Dimensions (mm)	127 x 227 x 40	178 x 227 x 45	248 x 323 x 55
Order Code	EXTLH1/3A4	EXTLHA5	EXTLHA4



Fully Recyclable

Stickers, Labels & Window Graphics

Made to measure stickers and decals that stand out.

- Self-adhesive or self-cling messaging or promotion on any smooth flat surface.
- All sizes and shapes.
- Long-life, indoor/outdoor, permanent/removable, tamper-resistant, clear/frosted... the options are endless.
- We also offer security/one-way vision window graphics.

 Made to order



Stand-Off Sign Fixings

Add an architectural finish to any wall mounted sign panel.

As well as providing an attractive stand-off feature for any sign panel material, these fixings will accommodate an uneven wall surface, which could include any texture or render present on brick or stone wall.

- Allows air to move freely across both the front and rear of the sign panel.
- Eliminates condensation or dirt build-up from behind, essential for clear sign materials, ensuring the message is always visible.
- No apparent screw heads, concealed mounting method acts as an effective tamper deterrent.
- Holds sign panel thicknesses from 2mm to 12mm.
- Supplied in pairs in protective polythene enclosures.
- Screws and wall plugs are not included (since no two surfaces are ever the same, fixings should be selected to suit).
- Use 321 grade Stainless Steel stand-offs for long life outdoors.

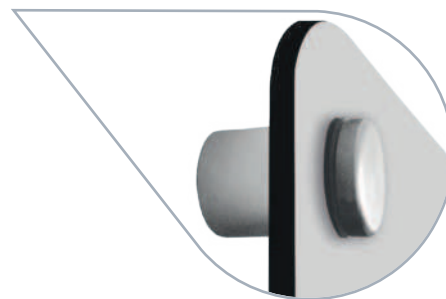

Stand-Off Sign Fixings as used in our Wall Mounted Information Displays.



13mm diameter

Item	O/A Dimensions (Dia x Stand-off height mm)	Panel Thickness Range (mm)	Pack Options	Order Code
Stainless Steel Self Colour	13 x 19	2 – 10	2/100	13X19SSSC
Aluminium Satin Silver	13 x 19	2 – 10	2/100	13X19ALSS
Aluminium Chrome Plated	13 x 19	2 – 10	2/100	13X19ALCP
Brass Plated Gold	13 x 19	2 – 10	2/100	13X19BRPG

19mm diameter

Item	O/A Dimensions (Dia x Stand-off height mm)	Panel Thickness Range (mm)	Pack Options	Order Code
Stainless Steel Self Colour	19 x 25	2 – 12	2/60	19X25SSSC
Aluminium Satin Silver	19 x 25	2 – 12	2/60	19X25ALSS
Aluminium Chrome Plated	19 x 25	2 – 12	2/60	19X25ALCP
Brass Plated Gold	19 x 25	2 – 12	2/60	19X25BRPG

Stand-Off Sign Fixings Guidance

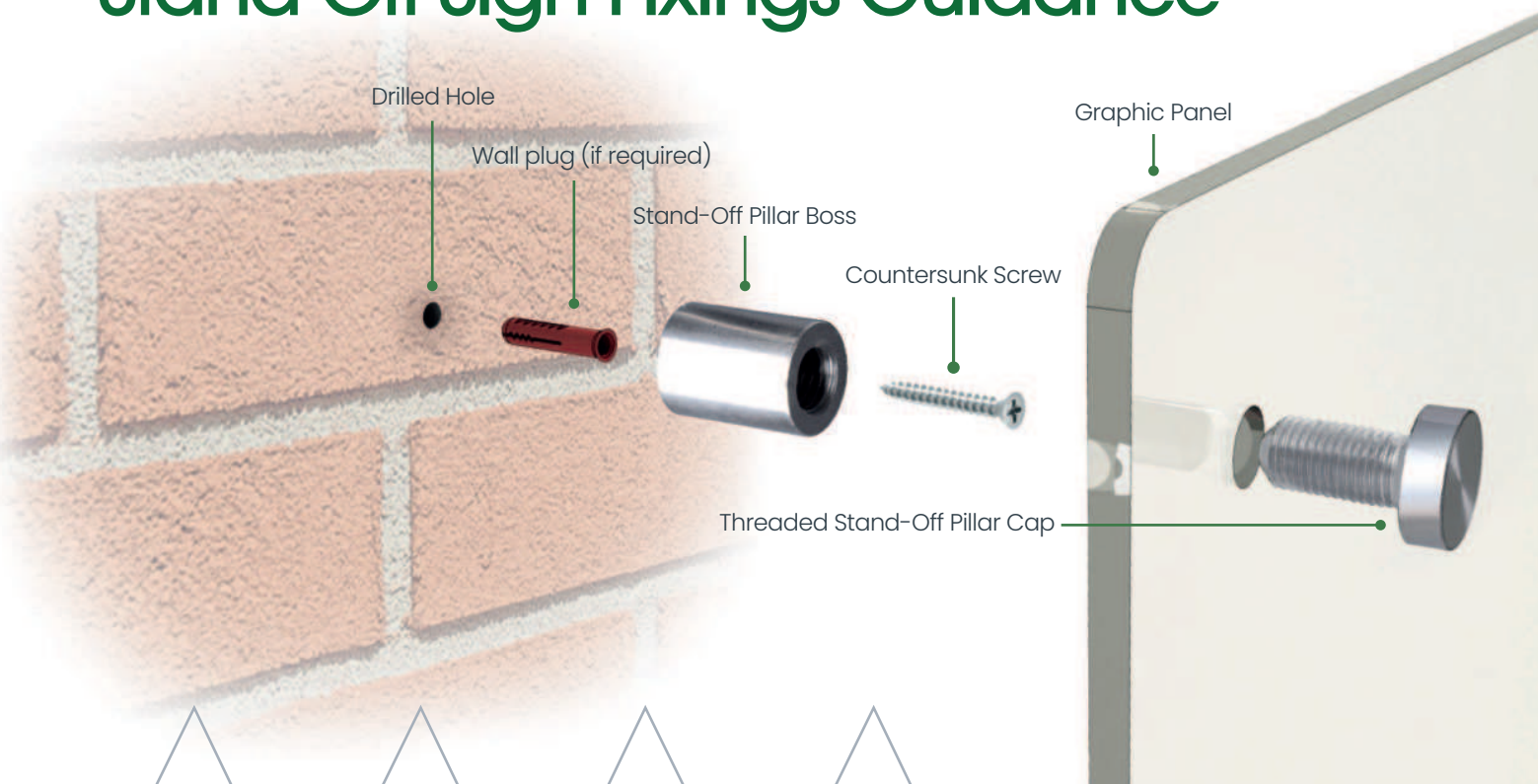

Aluminium
(Chrome Plated)



Brass
(Plated Gold)



Stainless Steel
(321 grade, brushed)



Aluminium
(Satin Silver)



Fully Recyclable

Screw Selection Guide			
Stand-off Pillar Size	Max. Screw Head Dia.	Max. Screw Thread Dia.	Hole Size in Sign Panel
13mm dia.	6.6mm	No. 6 (3.5mm)	8mm Required
19mm dia.	8.0mm	No. 8 (4.2mm)	10mm Required



BRIDAL EXPO

SUNDAY | MAY
21 | 12-4

FREE
ENTRY



BOUTIQUE



Indoor

Freestanding/Floor Mounted

Whether you wish to enhance an in-store promotion, or guide or inform customers or visitors, freestanding portable displays which can be repositioned quickly for tactical advantage are essential pieces of marketing equipment.

This section not only includes stands in various styles and sizes for the display of posters, chalkboards and marketing literature but also a range of portable exhibition displays that are as much at home in a retail environment, showroom or reception area as they are at a conference or on a trade exhibition stand. These Roll-Ups, Banner Stands, Back-Drops and Promotional Counters do everything that is asked when it comes to displaying a beautifully printed graphic, all in an easy to transport form with carry case included.

For the floor itself we offer our impressive Signtac® Self-Adhesive Floor Graphics range (see page 76). For entrances or reception areas, the re-positionable rubber backed promotional Feature Floor Mat offers a great opportunity to take advantage of the floor as an untapped advertising space, whatever the flooring surface.

Easel by Woodworkz®

Woodworkz® is our joinery-quality brand of in-house manufactured real wood sign and display products.



We only use sustainable and certified timber sourced from approved sawmills and distributors.

- Simple, low-cost design offering the widest choice of display options on the market.
- Non-slip rubber feet protects floors and helps keep legs in position.
- Part assembled for packing and very quick to erect - no tools required.
- Stock 'Country Oak' finish.
- Custom colours available made to order (minimum order quantity 10).
- Easel Chalkboards available separately. See opposite.
- Also suitable for printed panels (max 13mm thick) or poster frames up to 800 x 1200mm/A0 in portrait or landscape orientation.
- Adjustable panel supports provide five height positions.
- Additional pair of panel supports available separately to display 2x Small Easel Chalkboards/A2 poster frames.

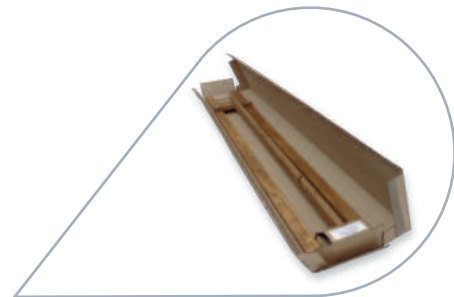

Flat packed and part assembled in individual box.



Fully Recyclable



Easel with alternative poster Snapframe.



Extra supports can be purchased separately.



2x small boards with extra set of supports.



Rear hinge detail.



Easel Chalkboards

- 6mm double-sided black edged melamine faced MDF in 3 stock sizes.
- Slightly rounded corners for safety.
- Suitable for use with traditional chalk or liquid chalk pens (see page 105).
- Direct to surface single or double sided print available.
- Suitable for alternative in-door uses e.g. drilling and screw-fixing to walls.

Product	O/A Dimensions (w x h x d mm)	Weight (kg)	Order Code
Easel	662 x 1549 x 735	2.6	WESLCO
Small Easel Chalkboard	397 x 600 x 6	1.32	WESLB397X600
Medium Easel Chalkboard	600 x 800 x 6	1.8	WESLB600X800
Large Easel Chalkboard	800 x 1200 x 6	4	WESLB800X1200
Additional Supports (pair)	35 dia. x 30 ea.	0.22 (pair)	KNOBBCO35PAIR



Pole & Rope Barrier



Choice of our Adfresco® Poles and Bases, with a range of rope colours.



Please Note: These ropes are designed for a long, maintenance free life indoors. Outdoor use in sunlight or rain may cause the rope colour to fade and reduce the life of the product.

- The LT Pole and Base (shown) offers the lowest cost option and is ideal for internal use.
- Quick and easy to assemble – simple pictorial instructions and spanner included.
- Ropes feature easy clip in attachment – intuitive quick release operation.
- Flat packed for ease of distribution and storage.
- Polished brass finish available made to order (minimum order quantity 100).



Twisted Rope.
Available in 3 stock colours.



Ropes feature quick and easy clip in attachment.



Chrome plated Eye Plate available for wall mounting

Item	Colour/Finish	Dimensions (mm)	Weight (kg)	Order Code
Pole and Top Ring	Premium Stainless Steel	Diameter: 113 (Pole Dia: 51mm)	1.0	CBBPOLE-SS
	Premium Black	Height: 881	1.5	CBBPOLE-BLK
	Budget LT Stainless Steel	Diameter: 100 (Pole Dia: 51mm) Height: 881	1.0	CBBPOLE-201
Base	Premium Stainless Steel	Diameter: 360	13.5	CBBBASE-SS
	Premium Black	Height: 66	13.5	CBBBASE-BLK
	Budget LT Stainless Steel	Diameter: 360 Height: 45	10.3	CBBBASE-201
Twisted Rope (cotton/polyester with weighted core and chrome end clips)	Red	Length: 1500 Diameter: 30	0.6	CBBTROPERED
	Black			CBBTROPEBLACK
	Blue			CBBTROPEBLUE
Eye Plate (for wall mounting)	Chrome	40 x 40 x 35 (w x h x d)	0.06	CBBEYERING

Poster Pillar

Single or double tiered freestanding poster display.



Double Tier

Single Tier

Simple slide-in assembly method:

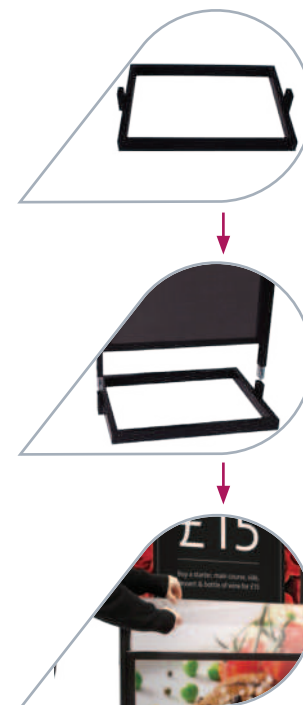

- Simple, functional, low cost double sided design.
- Posters/panels simply slide into place.
- Aluminium frames with hard-wearing silver anodised finish.
- Black high impact polystyrene (HIPS), inner sheets provide light block between back to back posters.
- Protective anti-glare PET poster cover sheets.
- Allen key and instructions supplied with each flat-pack unit.
- Alternative sizes and/or black finish available made to order.



Type	Poster/Panel Size (mm)	Display Area (mm)	O/A Dimensions (w x h x d mm)	Weight (kg)	Finish	Order Code
Double Tier	594 x 841 (x2)	566 x 813 (x2)	656 x 1820 x 450	8.7	Silver	PPDT59484ISA
Large Single Tier	500 x 1700	472 x 1672	561 x 1895 x 380	9.5	Silver	PPST5001700SA

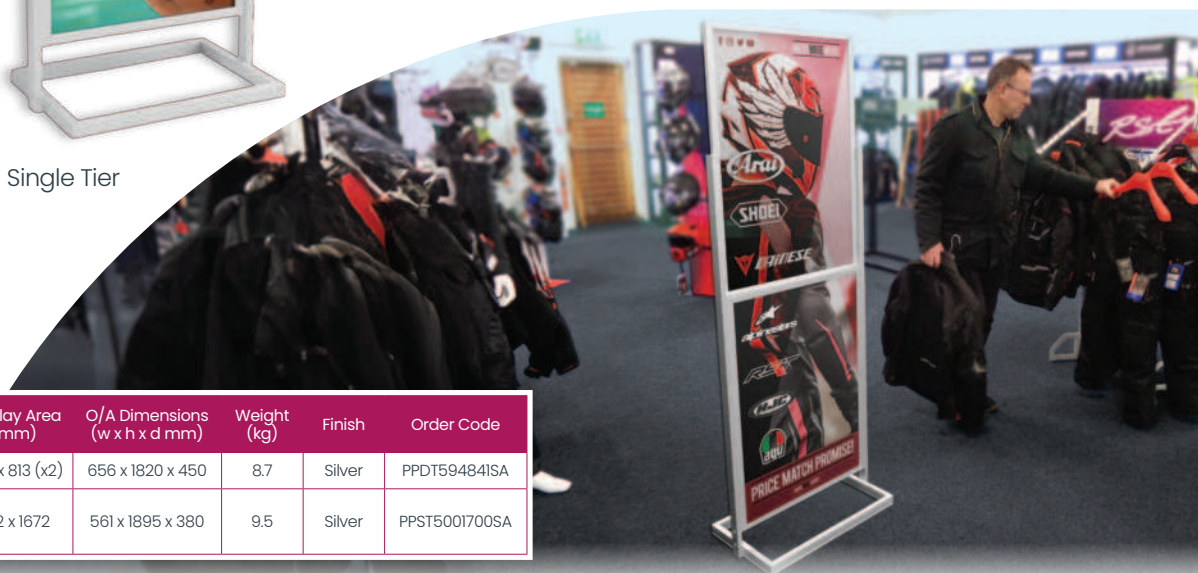

Metal Floor Display Stand

Low cost freestanding variable height interior banner display.



- Variable height telescopic display offers flexible double-sided display options.
- Attractive bright chrome finish steel.
- Quick and easy to assemble and change graphics between promotions.
- Adjustable clear spring clips provide secure banner display to suit a variety of graphic widths.
- Small footprint and low profile offers safe and unobtrusive advertising.
- Suitable for paper, card, PVC banner or textile graphic.
- Recommended graphic width is 297mm.
- Height of graphic can vary from 420mm to 1800mm.
- Print service available. Our standard double sided graphic offer is 610gsm Light Block PVC.

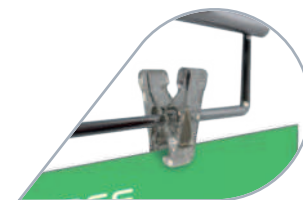

Clear polycarbonate spring clips to suspend graphic.



Telescopic pole clamp for easy height adjustment.



O/A Dimensions (w x h x d mm)	Weight (kg)	Order Code	
		Single Unit	Pack of 5
Min: 495 x 1250 x 251 Max: 495 x 2100 x 251	1.94	FLOORSTAND(1)	FLOORSTAND(5)

Decorative Menuboard

Freestanding internal poster display with front opening snapframe panel.



Landscape

Portrait

- Stylish internal poster display.
- Front opening snapframe for quick and easy poster change.
- Round corners for safety.
- Anti-glare PET poster cover ensures clarity when under spotlights.
- ABS base with hidden steel plate for added stability.
- Silver anodised aluminium leg (50 x 25mm oval).
- Available in A4 and A3 stock sizes.
- Poster insert – maximum 0.8mm thickness.

2 displays in 1

Simply undo thumb screw at rear and rotate to landscape or portrait.



Landscape



Portrait

Size	Dimensions (mm)	Display Area (mm)	Weight (kg)	Order Code
A4	O/A height: 1000 Frame: 240 x 327 Base: 250 x 330	279 x 192	3.5	DMBA4LP
A3	O/A height: 1200 Frame: 327 x 450 Base: 300 x 420	402 x 279	6.7	DMBA3LP



Recyclable: aluminium frame and pillar, PET poster cover, polystyrene back panel and mounting, ABS base cover, steel base plate

Portland Menustand

Easy to convert between portrait and landscape.



Landscape

Portrait

- Telescopic pole for easily adjustable height.
- Simple clip and slide mechanism for height adjustment.
- Front opening snapframes for quick and easy poster change.
- Soft round corners for safety.
- All adjustments made by hand, no tools required.
- Anti-glare PET poster cover sheets ensure clarity of message.
- Base features hidden steel plate for optimum stability.
- Available in A4 and A3 stock sizes.



Easily adjustable height – simply unclip and slide pole up/down.



Quick and easy to change between portrait and landscape format.



Soft round corners for safety.

Size	Format	Dimensions (w x h mm)	Display Area (mm)	Weight (kg)	Order Code
A4	Landscape	330 x 865-1205	190 x 277	5.2	FLEXIMENUBOARDA4
	Portrait	250 x 910-1250			
A3	Landscape	420 x 910-1250	277 x 400	6.8	FLEXIMENUBOARDA3
	Portrait	300 x 970-1310			



Recyclable: aluminim frame and pillar, PET poster cover, ABS base cover, steel pivot-boss and base plate

i-Stand

Stylish and minimalist, our A4 frameless interior poster display stand.



Can be used to display any alternative rigid sign panel up to 4mm thick.



- Folded clear acrylic panel for frameless A4 landscape poster display.
- Double-sided design provides walk-round visibility/dual messaging.
- Eye-level poster positioning in a tamper-resistant enclosure.
- Screw clamp holder secures poster panel, or any alternative rigid sign panel material up to 4mm thick.
- Black slim-line sectional pole offers 3 display height options.
- Solid steel plinth - low centre-of-gravity for high stability.
- Rubber foot pads protect floor surfaces.
- Simple Allen key assembly and poster access (Allen key included).



Screw clamp holder secures poster.



Rubber foot pads to protect floor surface.

Display Area (mm)	O/A Dimensions (w x h x d mm)	Weight (kg)	Order Code
A4	330 x 710 -1510 x 330	3	PDSA4B



Recyclable: aluminium pole and boss, steel base, acrylic poster holder

3 height options: 1510mm, 1110mm, 710mm.

Indoor
Freestanding/Floor Mounted

Showcard Stands

Low cost double-sided indoor floor stand for quick change promotional offers or as a 'bus stop' information sign.



A3 Tall Portrait



A4 Short Landscape

- Showcard frame in A4 & A3 sizes in 5 stock colours plus clear.
- Portrait or landscape option at assembly.
- Tall and short pole options, each offering telescopic variable height.
- Low-profile off-set grey steel base, suitable for sliding under pallets, dumpbins, case stackers, shelving fixtures, etc.
- Optional anti-glare clear PVC sleeve protector for paper posters.
- Suitable for any lightweight display material up to 2mm thick.
- Minimum order quantity 10.



6 stock colour frame options in 2 sizes.

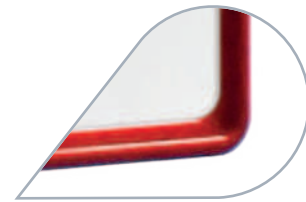

Frame.



Simple slide in graphic.

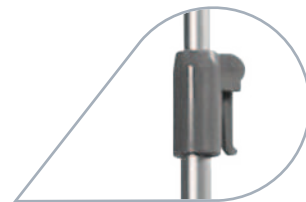

Telescopic pole in 2 sizes.



Recyclable: steel base, frame, T-clip, aluminium pole, pole adjustment clips

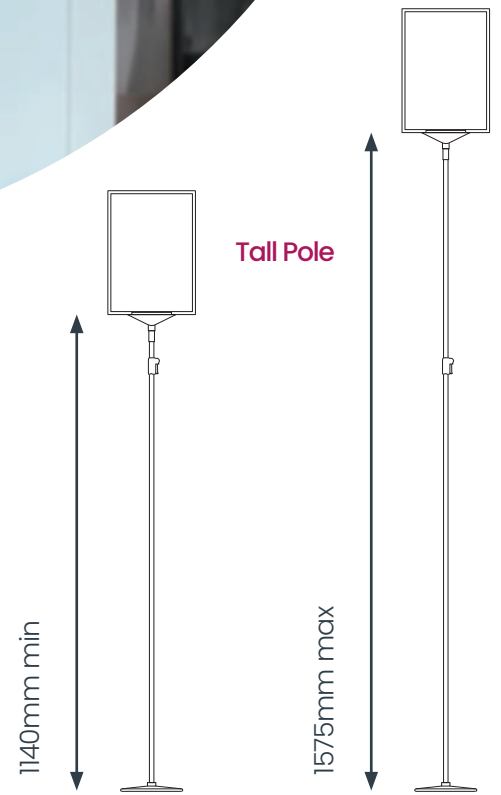
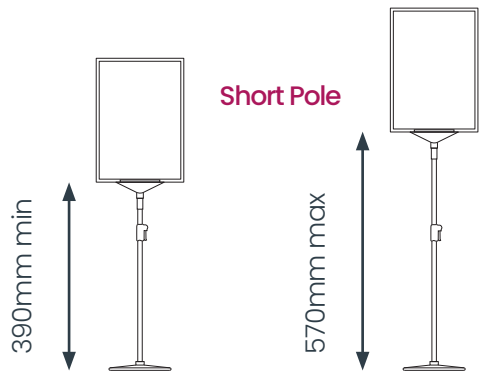
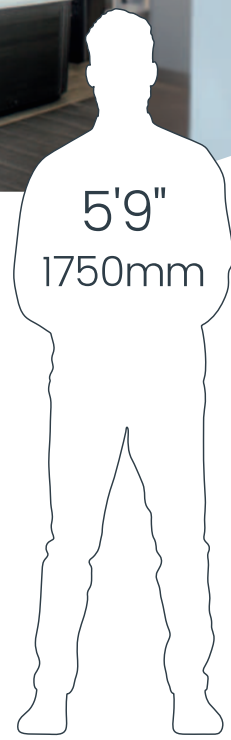

Poster Size	Pole Size	Display Area (mm)	O/A Dimensions (w x h x d mm)	Weight (kg)	Frame Colour	Order Code
A4	Short	194 x 280	Portrait - Min: 215 x 695 x 210 / Max: 215 x 850 x 210 Landscape - Min: 305 x 605 x 210 / Max: 305 x 800 x 210	0.55	Red / Blue / Green / Black / White / Clear	SCSFRAME***A4 + SCSPOLEA330 + SCSBASE3
A4	Tall	194 x 280	Portrait - Min: 215 x 1450 x 210 / Max: 215 x 1870 x 210 Landscape - Min: 305 x 1355 x 210 / Max: 305 x 1785 x 210	0.62	Red / Blue / Green / Black / White / Clear	SCSFRAME***A4 + SCSPOLEC1050 + SCSBASE3
A3	Short	280 x 404	Portrait - Min: 305 x 820 x 210 / Max: 305 x 1000 x 210 Landscape - Min: 428 x 695 x 210 / Max: 428 x 890 x 210	0.62	Red / Blue / Green / Black / White / Clear	SCSFRAME***A3+ SCSPOLEA330 + SCSBASE3
A3	Tall	280 x 404	Portrait - Min: 305 x 1570 x 210 / Max: 305 x 2000 x 210 Landscape - Min: 428 x 1445 x 210 / Max: 428 x 1870 x 210	0.69	Red / Blue / Green / Black / White / Clear	SCSFRAME***A3 + SCSPOLEC1050 + SCSBASE3
Optional Anti-glare PVC Poster Sleeve	-	A4: 194 x 280 A3: 280 x 404	-	-	-	SCSCOVERA4 SCSCOVERA3

*** Replace asterisks with required frame colour eg SCSFRAMEBLACKA4.

Basket Showcard Holders

Low cost double-sided indoor poster holder for baskets.



- For attaching A4 or A3 Showcard Frames to wire basket displays, dump bins, etc.
- 2 (tall and short) stock sizes.
- Simple spring loaded design for universal wire mesh application.
- No tools required.
- Minimum order quantity 10.



Poster Size	Pole Size	Display Area (mm)	O/A Dimensions (w x h x d mm)	Weight (kg)	Frame Colour	Order Code
A4	Short	194 x 280	Portrait - Min: 215 x 680 x 35 / Max: 215 x 865 x 35 Landscape - Min: 305 x 585 x 35 / Max: 305 x 775 x 35	0.19	Red / Blue / Green / Black / White / Clear	SCSFRAME***A4 + BASKETPOLEA300
A4	Tall	194 x 280	Portrait - Min: 215 x 770 x 35 / Max: 215 x 1070 x 35 Landscape - Min: 305 x 680 x 35 / Max: 305 x 980 x 35	0.22	Red / Blue / Green / Black / White / Clear	SCSFRAME***A4 + BASKETPOLEB400
A3	Short	280 x 404	Portrait - Min: 305 x 800 x 35 / Max: 305 x 990 x 35 Landscape - Min: 428 x 675 x 35 / Max: 428 x 865 x 35	0.26	Red / Blue / Green / Black / White / Clear	SCSFRAME***A3+ BASKETPOLEA300
A3	Tall	280 x 404	Portrait - Min: 305 x 895 x 35 / Max: 305 x 1190 x 35 Landscape - Min: 428 x 765 x 35 / Max: 428 x 1065 x 35	0.28	Red / Blue / Green / Black / White / Clear	SCSFRAME***A3 + BASKETPOLEB400
Optional Anti-glare PVC Poster Sleeve	-	A4: 194 x 280 A3: 280 x 404	-	-	-	SCSCOVERA4 SCSCOVERA3

*** Replace asterisks with required frame colour eg SCSFRAMEBLACKA4.

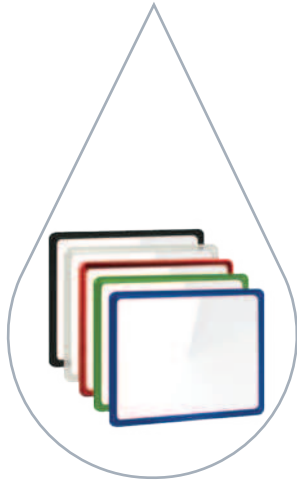

6 stock colour frame options in 2 sizes.

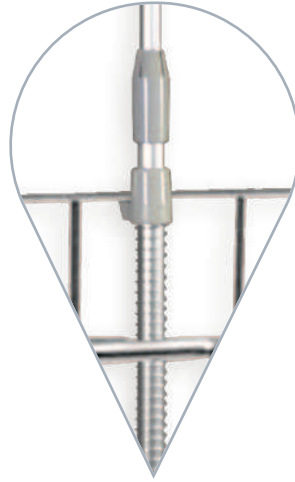

Spring loaded pole simply hooks into place.

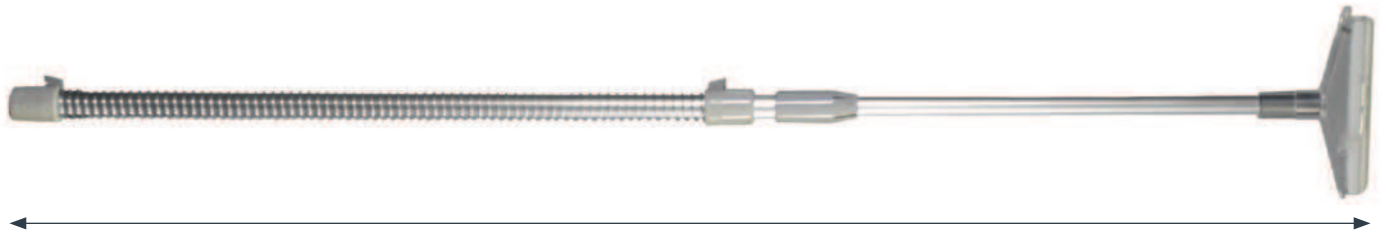
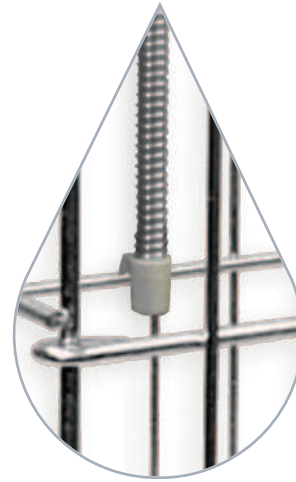

Short = 375 - 565mm
Tall = 470 - 765mm



Recyclable: frame, T-clip, aluminium pole, pole mouldings, steel spring



Flying Banner with Base Plate

High-impact flags on low-profile steel bases for indoor use only.



- Ideal for exhibitions, retail, malls, showrooms, sport and leisure venues.
- Eye-catching 110gsm polyester textile flags on sectional carbon composite poles.
- Flags in 3 shapes and 3 sizes – with a choice of hem options.
- Matt black base plate in 2 sizes: Small for all small flags and Large for all medium and large flags.
- Poles simply push-fit onto base spigot.
- For printed flags see pages 53-55.
- For additional product information see Flying Banners on page 50.



Recyclable: steel base plate, steel spindle

Item	O/A Dimensions (w x h x d mm)	Weight (kg)	Order Code
Small Base Plate	300 x 300 x 9 (plate 6mm thick)	4.2	FBBASEPLATESM
Large Base Plate	400 x 400 x 9 (plate 6mm thick)	7.3	FBBASEPLATELG

X-Banner

Low cost, high impact, eyeleted banner display – now in 2 sizes.

Instruction Video



- Simple fold away design – no tools required.
- For 600 x 1600mm or 1200 x 2000mm eyeleted banners. Front-lit materials are recommended.
- Banners simply hook into place – quick and easy to remove and replace.
- Carbon fibre top poles provide excellent tension and stability, ensuring banners do not sag over time.
- Black canvas carry bag included.
- Banner printing service available.
- Large X-Banner designed to sit side-by-side to form an impressive, easy to transport and very cost effective graphic backdrop.



Recyclable: aluminium legs, steel leg stay

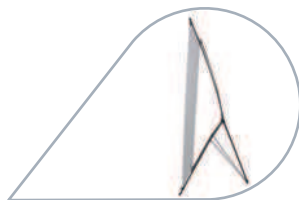

Side view.

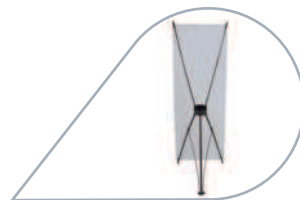

Rear view.

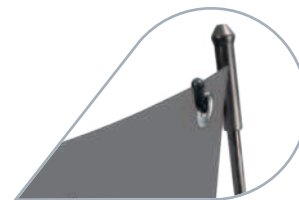

Simply hook eyeleted banner onto frame.

Banner Size (mm)	O/A Dimensions (w x h x d mm)	Weight (kg)	Order Code
600 x 1600	655 x 1690 x 690	2	XBAN600
1200 x 2000	1215 x 2060 x 920	2.7	XBAN1200



Graphia® Roller Banner

Style and performance at a super low price.



5 stock sizes available.



- Contemporary satin finish silver anodised aluminium cassette with flat 45mm fascia suitable for custom branding if required.
- Super-tough stylised satin black polyamide swivel feet and end caps complement the 'premium' appearance whilst enhancing product durability and performance.
- Perfectly parallel feet every time due to the integrated click stop feature (note: 600mm has a single centralised foot).
- Soft styling – no sharp edges.
- Fixed height sectional bungee pole.
- Top clamp rail and bottom adhesive strip makes banner installation a simple process.
- Complete with lightweight black carry case.
- 6 pack option for an even lower price.
- Buy hardware only or include printed banner in 220 micron tear-proof grey-backed lightblock polyester with non-reflective fine art canvas finish – PVC-free and no edge curl!

Banner Materials:

- We recommend lightweight materials such as 125–220 micron polyester or 220 micron matt opaque PVC.
- Do not use materials more than 300 micron thick.



Recyclable: aluminium cassette, sectional pole, steel retractor spring, moulded end cap and stabilisers



Top-hat pole/top rail connection.



Complete with lightweight black carry case.

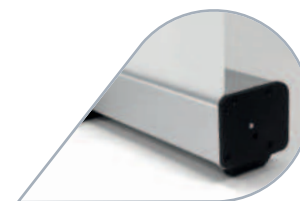

Satin black moulded end cap detail.

Banner Size (mm)	Display Area (mm)	O/A Dimensions (w x h x d mm)	Weight (kg)	Order Code (Single Unit)	Order Code (Pack of 6)
600 x 2035	600 x 2000	620 x 2090 x 260	1.3	GRB600(1)	GRB600(6)
800 x 2035	800 x 2000	820 x 2090 x 260	1.8	GRB800(1)	GRB800(6)
850 x 2035	850 x 2000	870 x 2090 x 260	1.88	GRB850(1)	GRB850(6)
1000 x 2035	1000 x 2000	1020 x 2090 x 260	2	GRB1000(1)	GRB1000(6)
1200 x 2035	1200 x 2000	1220 x 2090 x 260	2.2	GRB1200(1)	GRB1200(6)

Graphia® Roller Banner Connectors

Innovative accessory kit to create a double-sided roller banner.



Slide the connecting stay over the pole caps.

- Connects two Graphia® Roller Banners together easily and securely back to back to create a double-sided banner display.
- The specially designed connectors slide into the cassette of the banner, then a simple thumbturn lock secures the connector to the units - no tools required!
- Secure the two poles of the banner at the top by sliding the connecting stay over the pole caps.



Thumbturn lock mechanism concealed underneath.

Specially designed connectors slide into the banner cassette.



Order Code

RBDSC



Rollsby

For all round value, premium roll-ups don't come any better than this.



Premium padded carry case included with each unit, featuring separate pocket for pole and adjustable handle/shoulder strap.



- Single sided premium roll-up for interchangeable banners.
- 2 popular stock sizes – 800 and 850mm banner widths.
- Top clamp rail and bottom velcro strip makes banner installation and update a simple process.
- Two spare self-adhesive velcro strips supplied with each unit for future banner updates.
- Telescopic pole for 1550 – 1990mm height adjustment.
- Stylish silver anodised aluminium casing with black end caps and pole fittings – tough and hard wearing.
- Central stylised chrome foot.
- Premium padded carry case included with adjustable carry strap.
- Buy hardware only or include printed banner in 220 micron tear-proof grey-backed lightblock polyester with non-reflective fine art canvas finish – PVC-free and no edge curl!

Banner Materials:

- We recommend lightweight materials such as 125–220 micron polyester or 220 micron matt opaque PVC.
- Do not use materials more than 300 micron thick.

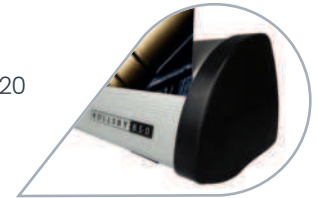

Hard wearing/protective end caps.



Stylish chrome foot.



Top clamp rail includes black push-fit end caps.

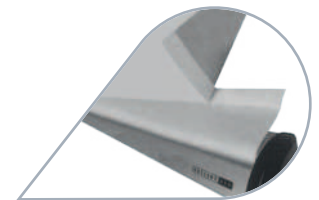

Velcro banner installation.



Recyclable: aluminium canister and pole, steel retractor spring, ABS end caps

Banner Size (w x h mm)	Display Area (w x h mm)	O/A Dimensions (w x h x d mm)	Weight (kg)	Order Code (Single Unit)	Order Code (Pack of 6)
800 x 1760-2200	800 x 1550-1990	860 x 1700-2310 x 400	2.69	ROLL800(1)	ROLL800(6)
850 x 1760-2200	850 x 1550-1990	910 x 1700-2310 x 400	3.4	ROLL850(1)	ROLL850(6)

Promo Counter

Heavy duty flat-pack promotional counter.



- Portable convex flat-pack design - quick and easy to assemble.
- White laminate top.
- Durable aluminium frames with silver anodised finish.
- White foam PVC display panels.
- Panels suitable for vinyl application or direct to surface print*.
- Optional black carry bags available separately.

* Due to possible curvature in convex panels, caution is required when printing direct to surface with flatbed digital printers.

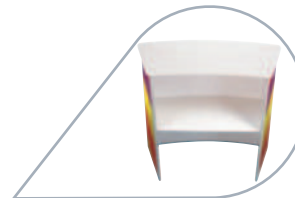

Back view.



Optional carry bag available.
Order code: CONVXBG.



Recyclable: aluminium frame,
foam PVC fascia panels

O/A Dimensions (w x h x d mm)	Panel Sizes (w x h mm)	Weight (kg)	Order Code
1060 x 930 x 580	Front: 980 x 878 (x1) Sides: 438 x 878 (x2)	18.1	CONVXW

Maximum Loads - counter: 15kg / shelf: 6kg.

Curved Pop-Up

Great quality. Amazing value for money!

Instruction Video



Each hardware kit includes:

- Collapsible aluminium frame (12mm diameter, silver finish) with black injection moulded fittings – sturdy, durable and long lasting.
- Set of magnetic bars and roll of magnetic B tape.
- Roll of magnetic A tape (for vertical panel edges).
- 2 x 150W clip-on spotlights with cable and plug.
- Semi-rigid trolley/case with built-in wheels and telescopic handle.
- Self adhesive header and kicker strips for panel reinforcement and shaping.
- Panel material is not included if printing your own graphics.

Printed Panels (optional):

- Stand-out digital print on 400 micron opaque white rigid PVC.
- Supplied ready to fit with header/kick-strips pre-applied.
- Option to have laminated in 80 micron matt textured scratch resistant PVC for increased durability and longer life.



Recyclable: aluminium frame sections, steel springs

Size	Dimensions (w x h x d mm)	Option	Total Weight (kg)	Availability	Order Code
3 x 3	O/A: 2610 x 2320 x 660 Panel area: 3440 x 2300 Visual front: 2497 x 2300	Hardware kit	21	Stocked	PUC3X3
		+ Printed panels	27	Made to order	PUC3X3PVCDIGSOFT
		+ Lamination	29	Made to order	PUC3X3PVCDIGSOFT-LAM
4 x 3	O/A: 3120 x 2320 x 945 Panel area: 4140 x 2300 Visual front: 3196 x 2300	Hardware kit	26	Stocked	PUC3X4
		+ Printed panels	33	Made to order	PUC3X4PVCDIGSOFT
		+ Lamination	36	Made to order	PUC3X4PVCDIGSOFT-LAM



Hard Trolley Case/Counter

For Curved Pop-Ups.



- Sturdy yet lightweight moulded polyethylene case.
- Built-in wheels for ease of movement.
- Stores all Curved Pop-Up components with space for optional graphic wrap.
- Optional black ABS counter top simply unfolds and clips into place.
- Optional Graphic Wrap, either plain or pre-printed, includes magnetic fitting strips. Graphic Fitting Strips are available separately for your own graphic wrap production if preferred.



Graphic Wrap and Counter Top available separately to convert Trolley Case into attractive Counter.



Built-in wheels for ease of movement.



Recyclable: polyethylene case, PVC graphic wrap, ABS counter top, steel hardware

Size	O/A Dimensions (w x h x d mm)	Weight (kg)	Colour	Order Code
Case	593 x 890 x 500	7	Black	MPUC
Counter Top	700 x 500 x 8	2	Black	MPUCTT2
Graphic Wrap	1570 x 755 x 0.46	0.8	White	MPUCGW
Graphic fitting strips only	51 x 755 x 6	0.3	Silver	GWSTRIPS



Decorative Brochure Stand

Freestanding A4 brochure display plinth.



- A4 brochure display plinth, available in portrait or landscape.
- Clear 3mm polycarbonate display shelf for optimum strength (depth: 100mm).
- Header space provided for graphics if needed.
- Silver anodised aluminium stanchion (50 x 25mm oval).
- Moulded silver plastic base with hidden steel plate for stability.
- Supplied with screws and Allen key for easy assembly.



Display shelf assembly (Allen key supplied).



Base/leg assembly (Allen key supplied).

  **Recyclable:** polycarbonate shelf, aluminium pillar, ABS base cover, steel base plate

Poster Size	Format	O/A Dimensions (w x h x d mm)	Weight (kg)	Order Code
A4	Landscape	250 x 970 x 330	3.5	DBSA4L
	Portrait	250 x 1000 x 330		DBSA4P

Spacemaster

Freestanding brochure display with space saving cantilever design.



- Compact and easy to use.
- Supplied complete and ready to use – no assembly required.
- Base fascia suitable for permanent branding (e.g. vinyl graphics).
- Includes 5 x A4 high impact polystyrene brochure holders.
- Supplied complete with black padded carry bag.
- Literature can remain in place when folding down, although we suggest removal of top literature.
- Ideal for presentations, exhibitions, conferences and events.



Recyclable: polystyrene brochure holders, steel side plates, ABS moulded fascia and plinth

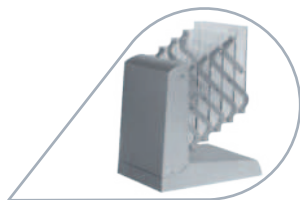

Compact and easy to store.

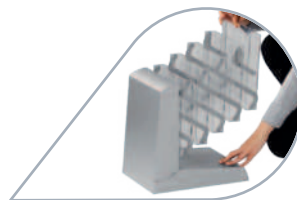

Hold base firmly and gently pull brochure holders upwards.

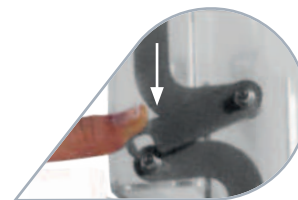

Hook levers to secure the brochure holders in place.

Base Fascia (w x h mm)	O/A Dimensions (w x h x d mm)	Weight (kg)	Order Code
250 x 280	Erect: 261 x 1345 x 340 Collapsed: 261 x 445 x 340	4.2	SPCEMSTRA4



Modular Pole Display

Low cost freestanding display system for posters, brochures & banners.



2-channel pole with
2 x 600mm wide Banner Set.



2-channel pole with Slide-In
Frames and Banner set.



2-channel pole with Poster Frames
(round corners) and steel Brochure Shelves.

- Ideal for internal/temporary sheltered outdoor use.
- Huge range of display options.



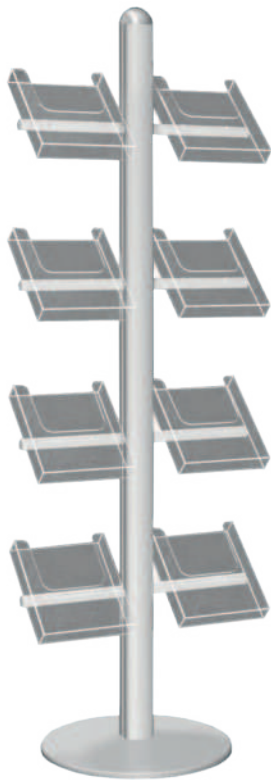

2-channel pole with side mounted Brochure Holders.



4-channel pole with Slide-In Frames and steel Brochure Shelf.



4-channel pole with Slide-in Frames.



2-channel pole with 4 x steel Brochure Shelves.



Standard Components

For modular pole display.



2-channel pole with circular base and domed end cap.

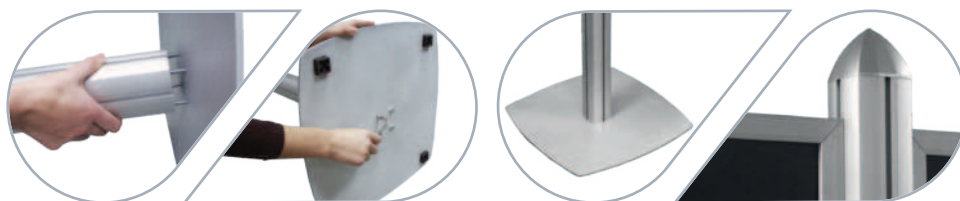

4-channel pole with square base and pyramid end cap.

Pole & Base

- 70 x 70mm silver anodised aluminium poles.
- Silver powder coated steel bases.



Recyclable: aluminium poles, steel bases, polystyrene end caps

Pole Type	Base Dimensions (mm)	O/A Height (mm)	Weight (kg) inc. base	Order Code
2-channel	450 (diameter) x 35	1920	12.4	BP2
4-channel	450 x 450 x 35	1920	12.4	BP4



Poster Frames

- Front opening aluminium snapframes for quick and easy poster change.
- 30mm profile with round corners.
- Option to use in portrait or landscape format.
- Supplied with pre-fitted channel slide/clamps.
- Alternative sizes with round or mitred corners available made to order.



Fully Recyclable

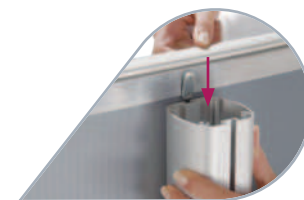

Slide-in assembly.

Corners	Poster Size	Weight (kg)	Order Code
Round	A2	1.7	BPFRAMEA2
Round	A1	2.8	BPFRAMEA1

Standard Components

For modular pole display.



Steel.

Brochure Shelves

- 2 x A4 portrait/1 x A3 landscape angled shelves.
- Silver powder coated steel.



Fully Recyclable

Material	O/A Dimensions (w x h x d mm)	Weight (kg)	Order Code
Steel	460 x 310 x 40	1.8	BPSTEELSHLF



2-channel pole and Slide-in Frame assembly.



Slide posters into the frame.

Slide-in Frames

- Silver anodised aluminium frames with open top end.
- Clear PET poster cover sheets.
- Frames can be mounted in either portrait or landscape format.
- Black polystyrene inner sheet included to provide light block between back-to-back posters.



Fully Recyclable

Poster Size	O/A Dimensions (w x h mm)	Weight (kg)	Order Code
A4	Portrait: 233 x 320 Landscape: 320 x 233	0.83	BPSLIFA4
A3	Portrait: 320 x 443 Landscape: 443 x 320	1.2	BPSLIFA3
A2	Portrait: 443 x 617 Landscape: 617 x 443	1.82	BPSLIFA2

Standard Components

For modular pole display.



Banner Set (Poster Hangers)

- Supporting arms simply slide into pole and can clamp in place at any height.
- Aluminium Poster Hanger rails top and bottom, suitable for paper or banners up to 1mm thick.
- Concealed banner suspension.
- Printed banners available.



Recyclable: aluminium supporting rails and arms

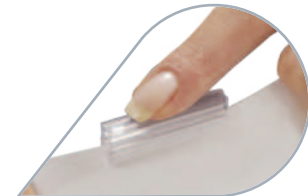

Banner Height (mm)	Banner Width (mm)	Weight (kg)	Order Code
Up to 1700	400	0.28	BPBANARM400
Up to 1700	500	0.34	BPBANARM500
Up to 1700	600	0.41	BPBANARM600

Standard Components

For modular pole display.

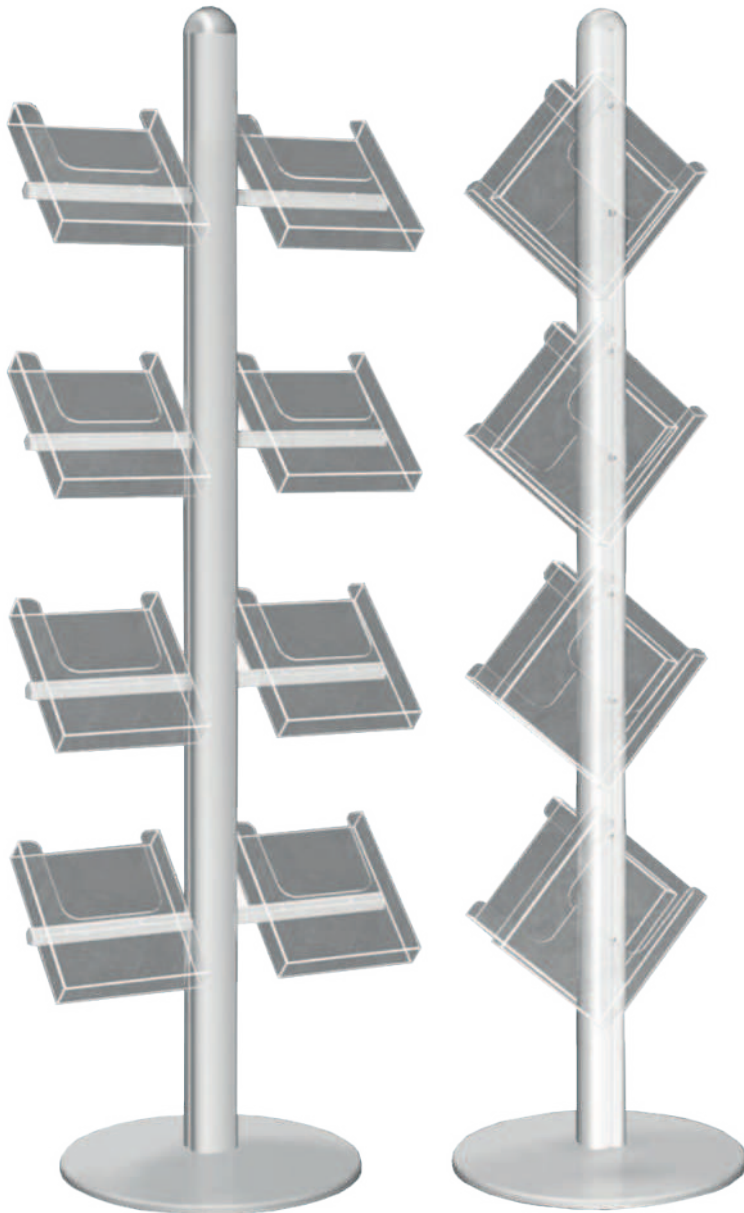

Brochure Holders.

- Crystal clear injection moulded styrene.
- Options for direct pole mounting or side mounting.



Fully Recyclable

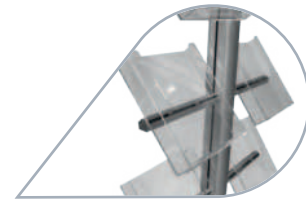

Holders with side mounting arms.

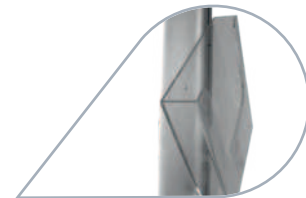

Angled pole mounted holders.

Type	Size	Weight (kg)	Order Code
With side mounting arm	A5	0.55	BPSIDESHELFA5
With side mounting arm	A4	0.85	BPSIDESHELFA4
Angled for pole mounting	A4	0.45	BPANGBHA4

Basket Liners

Increase impulse sales with these quick, easy, low-cost inserts.



- Increase impulse sales amongst basket shoppers.
- Scuff resistant printed promotional inserts.
- PVC or polypropylene material options.
- Quick, easy and cost-effective.
- Available in square cut or custom shapes.

 **Made to order**



Quick to fit, adhesive-free, just drop into place on the basket base.



Feature Floor Mat

Floor advertising – the great untapped opportunity!



- The floor is a great place to grab attention in shops, showrooms, receptions and events.
- Stunning print and colour reproduction.
- Feature Floor Mats can be tactically placed by chillers, counters, product displays or entrances.
- 100% polyester on a non-slip rubber backing.
- Hard wearing with safe low-profile edges.
- Simply drop into position – no adhesive required.
- Bespoke sizes available up to 3800mm x 1500mm.
- 100% recyclable.



Dimensions include 20mm black low-profile border.



Washable



Fully Recyclable

Standard sizes
(mm)

600 x 400

750 x 500

850 x 600

1200 x 850

1500 x 850





Indoor Wall/Window Mounted

Snapframes and the other wall mounted Poster Display, Noticeboard and Menu Case solutions detailed in the outdoor products section of this brochure are perfectly suited for indoor use so make sure you check these out if you don't see what you're looking for.

The same goes for our frameless wall mounted Chalkboards on page 104. Whilst suitable for outdoors their primary use will be indoors, for the hospitality sector and in pubs, bars and cafés in particular. All our Chalkboards have the option to be printed for premium brand endorsement at the point of sale, including the joinery-quality wood framed boards manufactured in our Woodworkz® production facility.

In this 'indoor only' section you will find some great display solutions for mounting to the inside of a window for outside viewing. Headlinerlite is an excellent repositionable solution for professional poster display, whilst our choice of printed Open/Closed Signs offers low-cost brand promotion with built-in functionality for the retailer.

If you are interested in the Illuminated Poster Frames on offer then make sure to check out our stunning Printed Backlit Poster Films, sometimes referred to as Duratrans, on page 194.

Open/Closed Signs - Slider

Simply slide to change message.

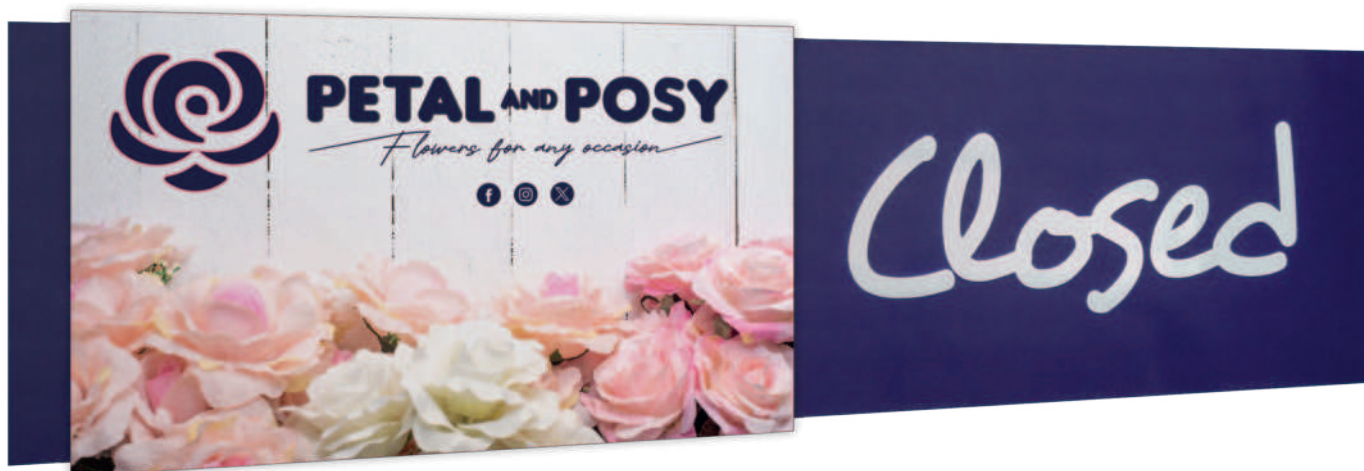

- 2 piece PVC sign.
- 400 x 105mm.
- For internal glass mounting.
- High bond adhesive backing included for easy installation.

 **Made To order**



High bond adhesive attaches to surface then simply slide left or right to change message.



Open/Closed Signs - Flipper

Simply flip to change message.

- Printed 2 sides on 900 micron high gloss PVC.
- Flip from open on one side to show closed on reverse.
- For internal glass mounting.
- Custom sizes and shapes available.
- Simple vacuum sucker allows repositioning in seconds.

 **Made To order**

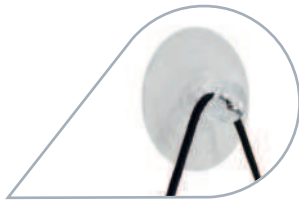

Vacuum sucker.



Custom shapes available.



Headliner

High visibility fixed poster display for windows.



Magnetic seals make it quick and easy to change posters.

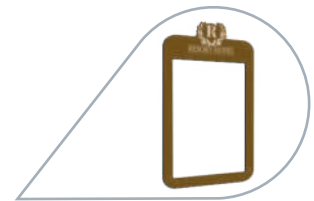

Custom shapes and sizes available.

- Single or double-sided poster display.
- Mounted directly to inside of glass with pre-applied clear double sided tape.
- No need for messy Sellotape or Blu Tack.
- Prime positioning for permanent brand presence.
- Hard wearing poster wallet* with magnetic seals ensures poster stays clean, dry and presentable.
- Made to order standard sizes: A4, A3, A2, A1 and 20" x 30".
- Available with square or rounded corners, with or without headers.
- Custom shapes and sizes available made to order (minimum order quantity 25).

* PVC poster wallet for sizes: A4, A3, A2 and 20" x 30". Polycarbonate poster wallet for A1 size.



Recyclable: PVC and polycarbonate

Instruction Video



Round corners
with constant
border



Square corners
with constant
border

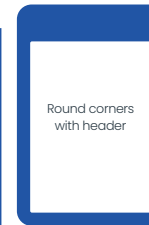

Round corners
with header

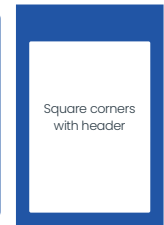

Square corners
with header



Headlinerlite

Incredibly simple, cost effective and repositionable window poster display.



- Versatile holder for single or double sided poster display.
- Vacuum suckers and keyhole cut outs make it incredibly quick and easy to install.
- Change posters in seconds – simply lift cover, replace poster and slot cover back in place.
- Consists of two cover sheets (UV stable 700 micron PET) and four vacuum suckers.
- Stock product sold/packed in pairs with window surface cleaning wipes and instructions.
- Available in 4 sizes: A4, A3, A2 and A1.



Recyclable:
PET & PVC suckers

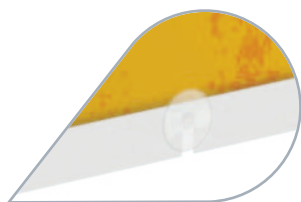
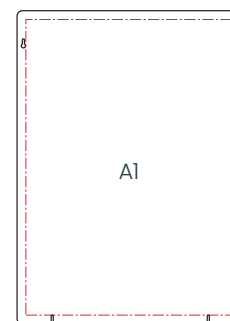
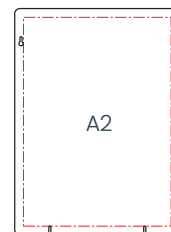
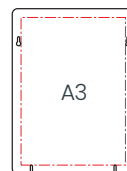

Window suckers for quick and easy installation and poster change.

Display Area (mm)	210 x 297	297 x 420	420 x 594	594 x 841
O/A Dimensions (w x h mm)	260 x 347	347 x 470	470 x 644	644 x 891
Weight per unit (kg)	0.2	0.35	0.6	1.15
Order Code (pack of 2)	HEADLINERLITEA4	HEADLINERLITEA3	HEADLINERLITEA2	HEADLINERLITEA1

Minimus

Patent No. 2531204

Minimalist design principles are behind Minimus, the world's simplest and lowest cost snapframe.

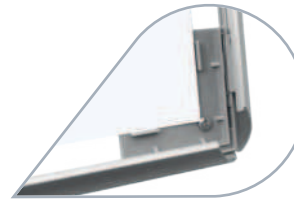

Patented corner mouldings with high tension serrated springs ensure strong grip on the poster.

An environmentally conscious snapframe solution!

- Once mounted to a smooth flat surface you wouldn't know Minimus is missing both rear aluminium frame and back panel.
- 25mm profile silver anodised frame in 4 stock sizes: A4, A3, A2 and A1.
- UV stable anti-glare poster cover sheet.
- Supplied with 4 screws/plugs and alternative self-adhesive pads for wall mounting.



Fix in place.

Insert poster and cover sheet.

Close the sides.



Fully Recyclable

Poster Size	Display Area (mm)	O/A Dimensions (w x h x d mm)	Weight (kg)	Pack Size	Order Code
A4	200 x 285	250 x 335	0.14	10	MINIMUSA4
A3	283 x 407	334 x 457	0.19	5	MINIMUSA3
A2	406 x 580	458 x 630	0.33	1	MINIMUSA2
A1	582 x 828	633 x 880	0.42	1	MINIMUSA1



Sign Nav

Versatile wayfinding display for walls and doors.

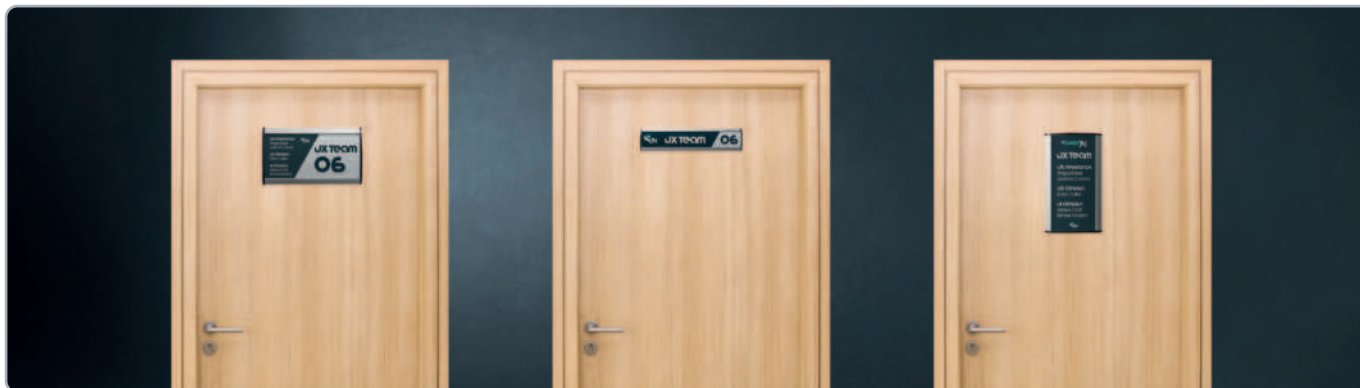

- Tamper proof yet easy to open with suction cup provided.
- Suitable for paper, plastic or any flexible material up to 1mm thick.
- Self adhesive strips on reverse for quick and easy installation, no tools or drilling needed.
- Create/update message insert using any desktop printer.
- Anti-reflective covers ensure clarity of message.
- Gives a high quality finish to any message.
- Available in 5 stock sizes.
- All sizes suitable for landscape or portrait display.

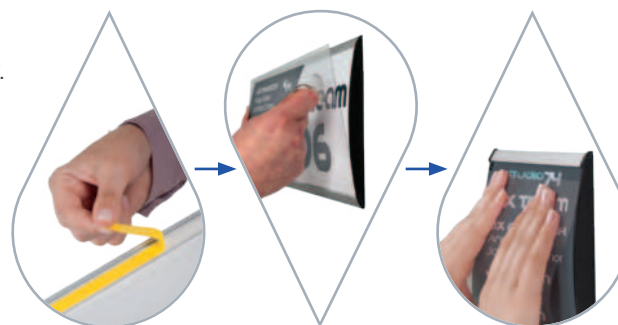

Self-adhesive strips for no tools installation.

Easily open the display with suction cup provided.

Cover can be pressed into place.



Recyclable: aluminium frame, PET poster cover, ABS end caps

Available in 5 stock sizes



Poster size (mm)	150 x 52	300 x 52	150 x 74	250 x 105	300 x 148
Display Area (mm)	150 x 46	300 x 46	150 x 68	250 x 99	300 x 142
O/A Dimensions (w x h x d mm)	156 x 68 x 14	306 x 68 x 14	156 x 90 x 14	256 x 120 x 14	306 x 162 x 14
Weight (kg)	0.1	0.2	0.1	0.3	0.4
Pack Options	2/10	2/10	2/10	2/10	2/10
Order Code	SNAV52X15	SNAV52X30	SNAV74X15	SNAV105X25	SNAV148X30



Edgelit XT Lightbox

Stylish low-profile illuminated poster frame for interior wall mounting (or suspending).



- Specially treated acrylic panel provides strong, even illumination.
- Front opening 25mm profile silver anodised aluminium snapframes for quick and easy poster change.
- 2.5m long power cable with 12v power supply and 3-pin plug.
- Anti-glare PET poster cover sheet ensures clarity of message.
- Slim, elegant design: single sided units only 19mm deep.
- Osram LEDs emitting 6500K daylight colour temperature.
- CE certificate supplied with each unit.
- Custom sizes* and colours available made to order.
- Printed Backlit Poster Films available, see page 194.

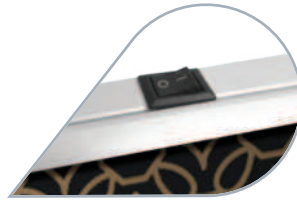

Built-in on/off switch.



12V 3m extension cable available (page 203).



Cable hanging kit available for suspending (page 203).



Recyclable: aluminium snapframe perimeter frame, PET poster cover, acrylic light panel

Poster Size	Display Area (mm)	O/A Dimensions (w x h x d mm)	Weight (kg)	Order Code
A3	277 x 400	329 x 452 x 19	3.4	LEDA3
A2	400 x 574	452 x 626 x 19	4.2	LEDA2
A1	574 x 821	626 x 873 x 19	8.1	LEDA1
A0	821 x 1169	873 x 1221 x 19	13.5	LEDA0

*Max size 850 x 1200mm. Max perimeter 4000mm. Max short side 850mm. Max long side 1500mm





Best Buy LEDbox

Illuminated poster display for interior wall mounting (or suspending).



- 25mm profile silver aluminium anodised snapframes for quick and easy poster change.
- Anti-glare poster cover sheet ensures clarity of message.
- 3.5m power cable with 12v power supply and 3-pin plug.
- Power on/off at mains plug switch. No built-in on/off switch.
- Osram LEDs emitting 6500K daylight colour temperature.
- CE certificate supplied with each unit.
- Custom sizes* and colours available made to order.
- Printed Backlit Poster Films available, see page 194.

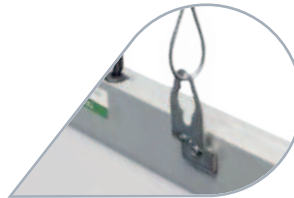

Cable hanging kit available for suspending (page 203).



12V 3m extension cable available (page 203).



Recyclable: aluminium snapframe perimeter frame, PET poster cover, acrylic light panel

Poster Size	Display Area (mm)	O/A Dimensions (w x h x d mm)	Weight (kg)	Order Code
A3	276 x 399	327 x 450 x 18	1.45	BBLEDA3
A2	399 x 573	450 x 624 x 18	2.5	BBLEDA2
20" x 30"	487 x 741	538 x 792 x 18	3.3	BBLED23
A1	573 x 820	624 x 871 x 18	4.5	BBLEDA1
30" x 40"	741 x 995	792 x 1046 x 18	6.35	BBLED34
A0	820 x 1168	871 x 1219 x 18	8.5	BBLEDA0

*Max size 850 x 1200mm. Max perimeter 4000mm. Max short side 850mm. Max long side 1500mm

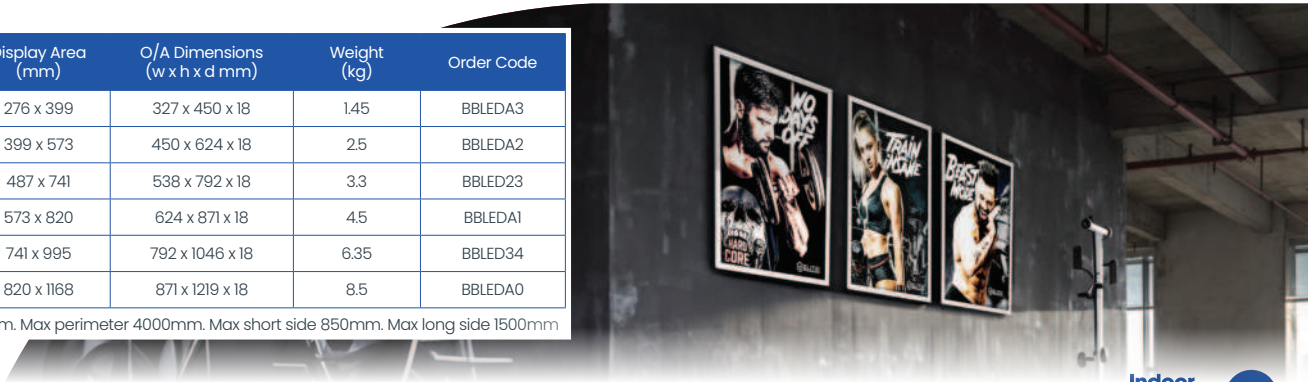



D-Light

Attractive convex lightbox for interior wall mounting.

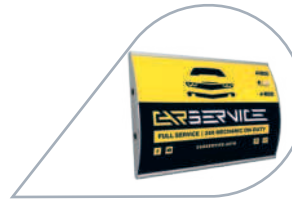

Option to use in landscape format – ideal for overhead and above-counter displays.

- Keyholes at rear for easy installation, suitable for portrait or landscape displays.
- Aluminium snapframe sides for quick and easy poster change.
- Silver finish steel case (RAL 9006).
- Acrylic opal diffuser panel ensures even light distribution.
- LED illumination gives low power consumption in use.
- 2m power cable, 12V power supply, wall fixings and CE certificate supplied with each unit.
- Custom sizes (max. size 850 x 1200mm) and colours available made to order.
- Printed Backlit Poster Films available, see page 194.

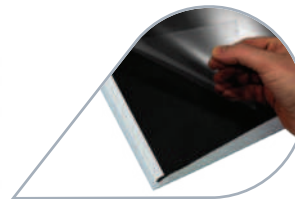

Antiglare PET cover sheet protects graphic insert.



Jack-socket and on/off switch.

Poster Size	Display Area (mm)	O/A Dimensions (w x h x d mm)	Weight (kg)	Order Code
A2	395 x 594	424 x 597 x 98	6	DLIGHTA2LED
A1	570 x 841	592 x 844 x 120	11.3	DLIGHTA1LED



Recyclable: aluminium snapframe sides, steel case, acrylic diffuser panel, PET poster cover

Chalkboards (Framed)

Reversible certified timber-framed chalkboards manufactured in our Woodworkz® production facility.



- Woodworkz® joinery quality for a long maintenance-free life.
- 4 stock sizes in 'Country Oak' finish.
- For wall mounting, suspending or lean-to floor standing – fixing kit included.
- Hard-wearing panel surface for traditional chalk or liquid chalk pens (see page 105).
- 3mm thick chalk-face laminated MDF panel in a 44 x 19.5mm timber frame – stained for indoor use only.
- Perfect for use with our Woodworkz® Easel (see page 112).
- Single or double-sided print available.
- Custom colour frames and sizes available made to order (minimum order quantity 20).



Fully Recyclable

Display Area (mm)	O/A Dimensions (w x h x d mm)	Weight (kg)	Order Code
273 x 372	361 x 460 x 19.5	1	CFCO361X460
372 x 575	460 x 663 x 19.5	1.65	CFCO460X663
575 x 775	663 x 863 x 19.5	2.8	CFCO663X863
705 x 1075	793 x 1163 x 19.5	4.1	CFCO793X1163

Interior Leaflet Dispensers

Wall mounted crystal clear injection moulded styrene leaflet holders in a wide range of stock sizes.



- Great prices on mass produced lines – 1/3 A4, A5 and A4 single compartment dispensers.
- Custom branding available made to order (minimum order quantities apply).
- Available printed (minimum order quantity 100).
- Additional freestanding models (see page 174).

Single Compartment



1/3 A4
wall mounted



A5
wall mounted



A4
wall mounted



Fully Recyclable

Description	Opening Size (mm)	O/A Dimensions (mm)	Pack Options	Order Code
1/3 A4 wall mounted	110 x 32	114 x 165 x 40	4/60	WH110BH
A5 wall mounted	159 x 32	163 x 165 x 40	4/45	WH160BH
A4 wall mounted	227 x 32	231 x 249 x 40	4/30	WH230BH
4 x A4 portrait stacked freestanding or wall mounted	230 x 32 (x4)	236 x 340 x 175	2/8	BH4C230
4 x A4 landscape stacked freestanding or wall mounted	336 x 32 (x4)	340 x 345 x 175	1/8	BH4C330



Multi Compartment



4 x A4 portrait stacked
freestanding or wall mounted

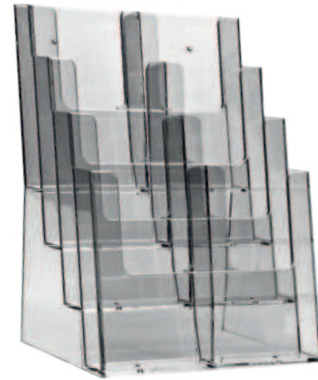

Dividers included for alternative compartment configurations:

4 x A5 landscape, 8 x 1/3A4 (DL) or mixed display combinations e.g. 2 x A4 with 4 x 1/3A4 (DL).



4 x A4 landscape stacked
freestanding or wall mounted



Dividers included for alternative compartment configurations:

8 x A5 portrait, 12 x 1/3A4 (DL) or mixed display combinations e.g. 4 x A5 with 6 x 1/3A4 (DL).

Wall Mounted Information Displays

Fully customisable combination poster and leaflet information boards.

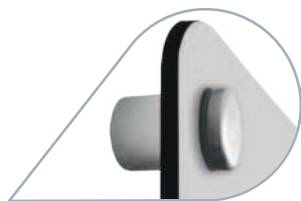

Stainless Steel stand-off fixings.



Secure screw fasteners for literature pockets.

Literature Pocket Fixing Guidance

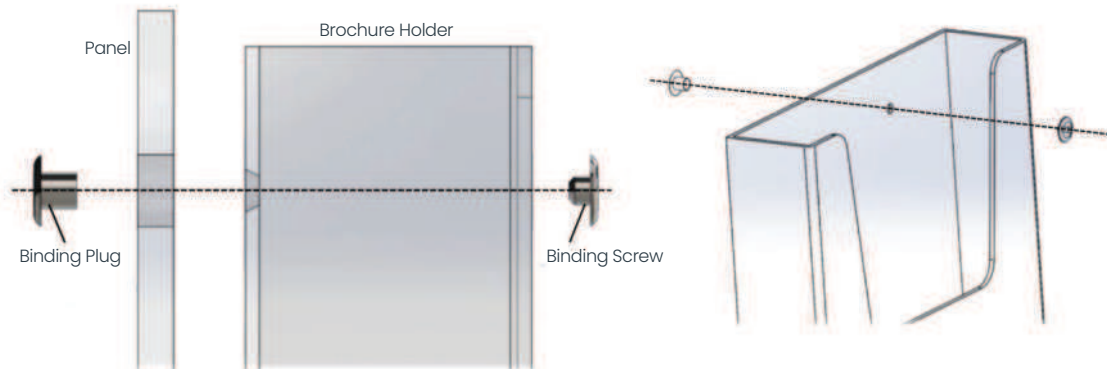

Fastener mounting – literature holders can be replaced individually if required

Our high-quality offer is based on a choice of 3 back panel materials with a set of stainless steel stand-off fixings:

- 5mm Clear Acrylic – plus clear acrylic poster holders and/or clear injection moulded styrene brochure holders.
- 5mm Frosted Acrylic – plus clear acrylic poster holders and/or clear injection moulded styrene brochure holders.
- 3mm Satin White Aluminium Composite (ACM) – plus silver anodised Minimus snapframe poster holders and/or clear injection moulded styrene brochure holders.
- Displays are individually packed with poster frames pre-fitted and brochure holders packed separately for fitting on site (to avoid damage).
- Panels are pre-drilled for both brochure holder attachment and stand-off wall fixings.
- Branding areas to back panels if required.
- Poster holder options – A4, A3, A2 and A1.
- Brochure holder options – 1/3 A4, A5 and A4.
- Made to order.

Individually select elements to create your perfect Wall Mounted Information Display.

Choose your back panel material:



3mm satin white aluminium composite (ACM)

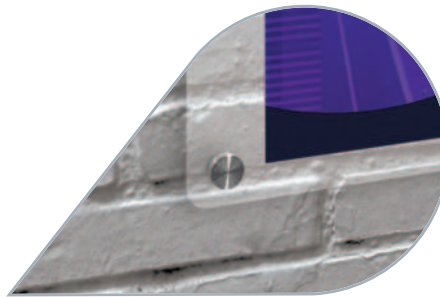

5mm clear acrylic

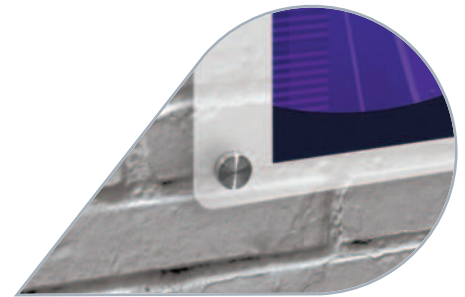

5mm frosted acrylic

Would you like any print on the back panel?

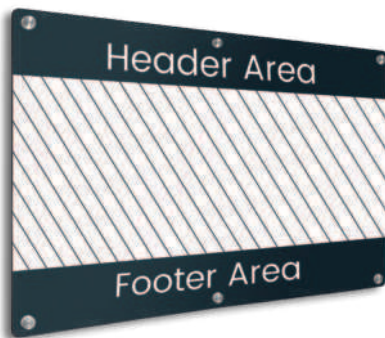

Header and/or footer area.



Print available anywhere on the back panel.

Choose your size and quantity of brochure holders:



A4



A5



1/3 A4

Choose your size and quantity of poster holders:



For Aluminium Composite Material back panels:

A4, A3, A2 or A1 Minimus Snapframes.



For Clear/Frosted Acrylic back panels:

A4, A3, A2 or A1 Acrylic Poster Holders.

Information Display Examples

The following examples are optimised for efficient back panel sheet usage. Please contact us to discuss any other size or configuration, or email a sketch.

Acrylic Back Panel

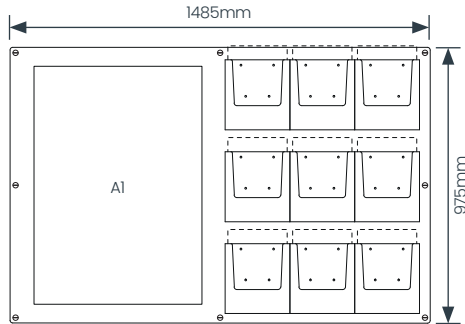

Display element	Quantity included	Order Code
A1 Poster Holder	1	ALGIA1POST9A4BH
A4 Brochure Holders	9	
Header area?	No	

ACM Back Panel

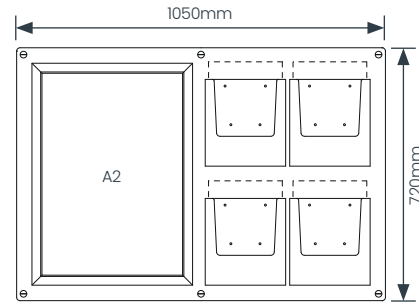

Display element	Quantity included	Order Code
A2 Minimus Snapframe	1	ACMMEIA2MIN4A4BH
A4 Brochure Holders	4	
Header area?	No	

Acrylic Back Panel

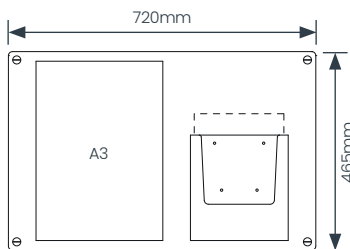

Display element	Quantity included	Order Code
A3 Poster Holder	1	ASMA3POSTIA4BH
A4 Brochure Holder	1	
Header area?	No	

Acrylic Back Panel

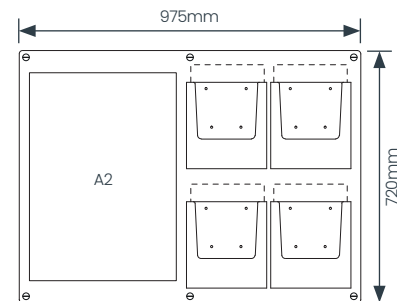

Display element	Quantity included	Order Code
A2 Poster Holder	1	AMEIA2POST4A4BH
A4 Brochure Holders	4	
Header area?	No	

Acrylic Back Panel

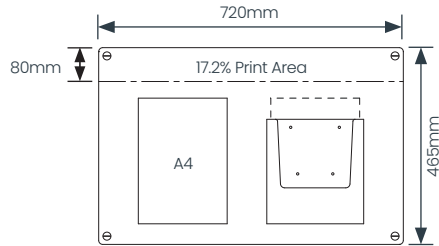

Display element	Quantity included	Order Code
A4 Poster Holder	1	ASMI4POSTIA4BHPH
A4 Brochure Holder	1	
Header area?	Yes	

ACM Back Panel

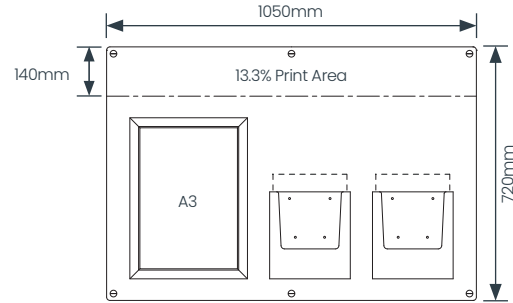

Display element	Quantity included	Order Code
A3 Minimus Snapframe	1	ACMMEIA3MIN2A4BHPH
A4 Brochure Holders	2	
Header area?	Yes	

Acrylic Back Panel

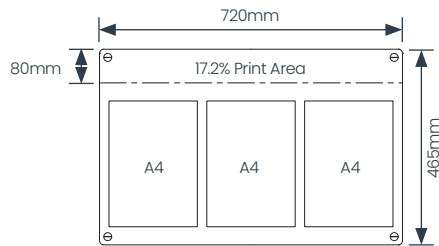

Display element	Quantity included	Order Code
A4 Poster Holders	3	ASM3A4POSTPH
A4 Brochure Holder	0	
Header area?	Yes	

ACM Back Panel

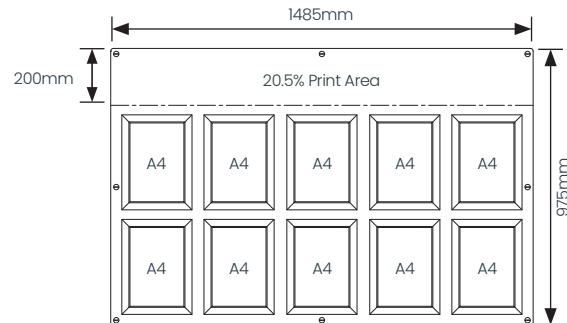

Display element	Quantity included	Order Code
A4 Minimus Snapframe	10	ACMLG10A4MINPH
A4 Brochure Holder	0	
Header area?	Yes	



Indoor Suspended/Hanging

For suspended window and ceiling display our Poster Hanger and Poster Clamp are low-cost industry standards. Poster Hanger would be our first choice for window dressing applications due to its narrow visual profile and matching double-sided appearance whilst the heavier duty Poster Clamp is suited to larger banners in-store and over aisles.

Both of these 'banner rail' products grip the suspended graphic along the top and bottom edge and provide a professional hanging solution for a range of materials and are easy to update. Importantly they keep the graphic straight and hanging true, unlike unsupported card which has a tendency to warp and bend.

Whether floor or wall space is at a premium or not, ceiling suspended advertising makes a lot of sense, in larger stores in particular. Mounted well above head height suspended displays are guaranteed to draw attention to promotions and is where customers will naturally look for navigational guidance around the store.

If you have lower level suspended ceilings with integrated lighting check out Freelight Plus – probably the lowest cost illuminated display available!

Poster Hanger

Perfect for paper, flexible banner materials and rigid plastics up to 1mm thick.

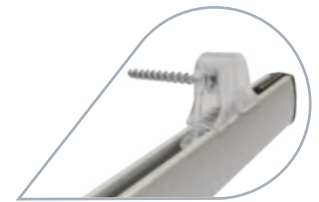

Adjustable hanging clips with key hole cut-outs for optional wall mounting.



- Plastic grippers make it easy to insert and remove graphics.
- The favourite choice of retailers for window suspended posters.
- Silver anodised finish as standard.
- Custom sizes and colours available made to order (minimum order quantity 25).
- Cable hanging kit available (see page 203).

Each set consists of:

- 2 aluminium rails (slim 20mm wide) with end caps and poster/banner grippers (2-7 per rail depending on size).
- Adjustable hanging clips on top rail.

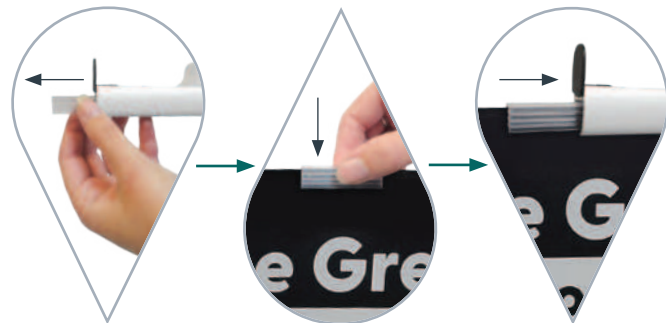

Remove grippers from rail.

Push onto poster.

Insert back into rail.



Recyclable: aluminium rails

Poster/Panel Width (mm)	300 (e.g. A4 or A3)	420 (e.g. A3 or A2)	600 (e.g. A2 or A1)	850 (e.g. A1 or A0)	1200
Weight (kg)	0.15	0.2	0.25	0.35	0.5
Order Code	PFX300	PFX420	PFX594	PFX841	PFX1200



Poster Clamp

Heavy duty gripping action for materials up to 0.5mm thick.



- Ideal for large/heavy weight posters, banners and textiles up to 500 micron thick. For suspending or wall hanging.
- Each set consists of 2x 25mm aluminium rails and 2 adjustable hanging clips.
- Silver anodised finish as standard.
- Custom sizes and colours available made to order (minimum order quantity 25).



Open clamping rail and insert poster edge.



Close clamping rail.

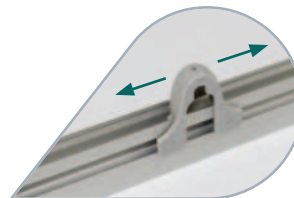

Adjustable hanging clips with key hole cut-out for wall mounting, plus cable hole.



Cable hanging kit available (page 203).



Recyclable: aluminium rails

Poster/Banner Width (mm)	500	700	1000
Weight (kg)	0.5	0.65	0.95
Order Code	PC500(M)	PC700(M)	PC1000(M)



Freelight Plus

EU Design Registration No. 000433131

Double-sided ceiling mounted display.



- No electricity. No maintenance. Probably the cheapest illuminated display available. Uses existing in-store lighting for illumination.
- Flat-pack design – easy to assemble and install.
- Graphic inserts are quick and easy to update.
- Printed inserts available.

Each kit includes:

- Crystal clear outer lens panel.
- Opal 'lampshade' PVC insert- ideal for translucent vinyl or printed graphics.
- Pair of satin white end caps.
- 2 ceiling hooks and 2 styles of button eyelets.



Recyclable: ABS end caps, polypropylene outer lens panel

O/A Dimensions (w x h x d mm)	Weight (kg)	Order Code
648 x 256 x 226	1.3	FREELIGHTUNB

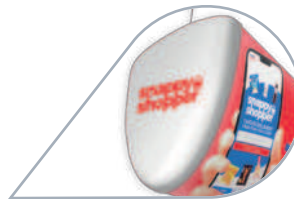

Custom coloured and/or pad printed end caps available made to order (minimum order quantity 500).



Existing Lighting

Suspended ceilings offer prime advertising space and, with existing lighting, are perfect for Freelight Plus.



Freelight Plus

With no need for wires or power, Freelight Plus is quick to assemble and simply hooks into place using the fixing kit supplied.



High impact, low cost advertising

Most of the benefits of a traditional lightbox, but without the cost and inconvenience!

Magnetic POS Flag Arm

Strong magnetic bracket attaches to any steel surface.



- Sometimes referred to as a Magnetic Aisle Flag Holder or Magnetic Aisle Fin.
- Perfect for double-sided projecting shelf messaging in supermarket and shopping aisles.
- For 210mm wide hanging graphic. Min height 297mm (A4) up to 1400mm.
- No mechanical fixings or adhesives – can be easily repositioned if required.
- Preassembled and ready to use straight out of the box.
- 180 degree base rotation allows mounting to horizontal or vertical surfaces.
- Clear polycarbonate sliding hanging hooks to suit variable graphic hole positioning.
- Quick and easy graphic change.
- Suitable for single-sided or double-sided promotional messaging in paper or lightweight card or banner fabrics.
- Minimum order quantity 5.
- Print service available. Our standard double sided graphic offer is 610gsm lightblock PVC.



Magnetic bracket and release button to rotate flag arm.



Mount to horizontal or vertical surfaces.



Ideal for supermarket shelving advertising.



Fully Recyclable

Weight (kg)	Order Code
0.17	MAGFLAGHOLDER



* BEVERAGES *

Café Latte £4.10
a double shot of espresso with steamed milk and a small layer of foam.

Flat White £4.10
a double shot of espresso with fat steamed milk.

Cappuccino £4.10
a double shot of espresso with equal parts steamed milk and foam.

Mochaccino £4.10
rich chocolate mixed with a double shot of espresso. Served with steamed milk and a small layer of foam.



* DESSERT *

Pecan Pie £4.10
Our classic pecan pie recipe is best served with whipped cream or a scoop of ice cream.

Cheesecake £4.10
Creamy and ultra smooth classic cheesecake with a buttery biscuit base.

Chocolate Cake £4.10
An airy light sponge, rich buttercream filling and dark chocolate crust - delicious!

Pretzel Bites £4.10
Perfectly soft and chewy mini cinnamon sugar pretzel bites - one of the all time bestest treats!



* BRUNCH *

Crustless Quiche £4.10
Quiche of the day - please see our chalkboard menu for more details.

Butternut Tart £4.10
Simple & beautiful - sit top over a fresh cheese, sage, nutmeg and salted caramel.

Chicken Chivito £4.10
This towering hero sandwich packs a multitude of delicious flavors.

Breakfast Tacos £4.10
Shredded beef, peppers and scrambled egg makes these breakfast tacos a fun favorite.

..... This is interesting!



65% of the world's coffee is drunk with different additives (milk, cream, spices, alcohol, sugar, salt, cinnamon, lemon)

35% of all coffee in the world is drunk without additives (black coffee without sugar and cream)



1 person in the world per day drinks 3 cups of coffee

Indoor Counter/Table/Shelf

Promotion at the retail shelf display, fixture, service counter, bar or table comes in many forms.

The display products in this section, whether generic or specialist in terms of their market orientation, can be very simple in their form and function, but that doesn't mean we don't give them the same 'design for quality' considerations we apply to all our products.

Lightweight products that are often handled daily and prone to be knocked over or dropped on the floor need to be hard-wearing, durable, hygienic and easy to clean. Minimalist design is as much about optimising the promotion or message as it is about low cost manufacture.

From ticket and menu holders to freestanding leaflet dispensers, poster displays and chalkboards there is a wide choice of solutions for updatable messaging. Counterstand Snapframes, Grip Talker and Grip Chalkers and Pivot Gripper are worthy of particular attention.

When it comes to permanently printed solutions for brand endorsement, or to stimulate a call to action at the point of sale, there are low cost Shelf Wobblers to premium acrylic Brand Blocks, Bar Runners and Counter Mats available.

Overture Menu Holder

Crystal clear menu holders for double sided paper inserts.



- Crystal clear injection moulded styrene.
- Designed for style and strength.
- Oval bases with round edges, stylish and easy to clean.
- Finger cut out on top edge, making it quick and easy to change inserts.



Available in 2 stock sizes



A5 Portrait



A4 Portrait



O/A Dimensions (w x h x d mm)	170 x 215 x 70mm	232 x 303 x 90mm
Pack Options	4/25	4/25
Order Code	OVRTMHA5	OVRTMHA4

Clear Menu Holder

Economical menu protection.



- Smooth, wipe clean PET sleeves and styrene bases.
- Transparent plinth for full visibility.
- Suitable for single or double sided paper inserts.
- Menu sleeve simply push fits in to base.
- Comes in packs of 2 or 10.

Available in 3 stock sizes



1/3 A4 (DL)



A5



A4



Fully Recyclable

O/A Dimensions (w x h x d mm)	100 x 220 x 50mm	152 x 238 x 63mm	212 x 330 x 86mm
Pack Options	2 / 10	2 / 10	2 / 10
Order Code	BHV100B + BHV100MH	BHV150B + BHV150MH	BHV210B + BHV210MH



Counterstand Snapframes

Stylish counter top poster frames.



Black
25mm Frame



Wood

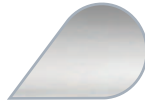

Silver



Black

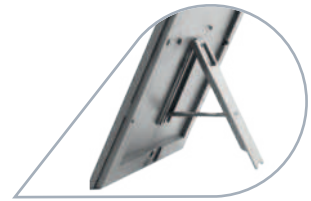

Clip-fit rear stay

- Front opening aluminium snapframes, for quick and easy poster change.
- Freestanding for versatile/tactical positioning.
- Clip-fit rear stay enables either portrait or landscape presentation.
- Anti-glare PET poster cover sheet ensures clarity of message.
- Includes screws and wall plugs for optional wall mounting.



Silver 14mm Frame.



Wood 25mm Frame.



Fully Recyclable

Poster Size	Frame Profile (mm)	Display Area (mm)	O/A Dimensions (w x h mm)	Weight (kg)	Finish	Order Code
A5	14	138 x 200	170 x 232	0.17	Silver	OPTIA514SA
					Black	OPTIA514BLK
					Wood	OPTIA514WD
A4	25	190 x 277	240 x 327	0.39	Silver	OPTIA425SA
					Black	OPTIA425BLK
					Wood	OPTIA425WD



Straight/Tilt Talkers

Crystal clear acrylic menu displays for paper inserts.

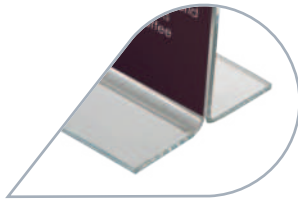
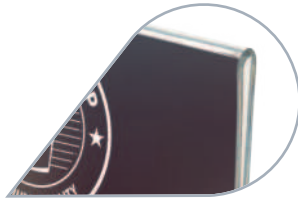

Straight Talkers

- For double sided vertical message display.
- Presents and protects any paper inserts.
- Open edges for poster insert.



Fully Recyclable

Size	O/A Dimensions (w x h x d mm)	Pack Options	Order Code
A6 Portrait	105 x 152 x 75	4/40	STRTA6P
1/3 A4 Portrait	105 x 212 x 75	4/40	STRTI/3A4P
A5 Portrait	150 x 212 x 75	4/30	STRTA5P
A4 Portrait	210 x 302 x 105	4/40	STRTA4P

Tilt Talkers

- For single sided angled message display.
- Presents and protects any paper insert.
- Open edges for poster insert.



Fully Recyclable

Size	O/A Dimensions (w x h x d mm)	Pack Options	Order Code
A6 Portrait	105 x 155 x 72	4/30	TILTA6P
1/3 A4 Portrait	105 x 215 x 72	4/65	TILT1/3A4P
A5 Portrait	150 x 215 x 72	4/40	TILTA5P
A4 Portrait	210 x 305 x 92	4/40	TILTA4P

Grip Talkers

Simple yet stylish menu holders featuring our spring powered 'grip-action' bases.



PET Sleeves

- For double sided paper inserts.
- Semi rigid, hardwearing PET, perfect for busy pub and restaurant environments.
- Available in 1/3 A4, A5 and A4 stock sizes.

Bases

- Aluminium with silver anodised finish as standard.
- Spring powered grip action - simply open by hand, insert panel and release.
- Suitable for self adhesive vinyl, polydome stickers or pad printed graphics.
- Custom base sizes, colours and finishes available made to order (minimum order quantity 100).
- Maximum pad printed height 14mm (minimum order quantity 50).

Other Display Options

- These bases are suitable for almost any rigid sheet material between 1-4mm thick. E.g. acrylic, PVC, PET and foam PVC.
- Printed panels available made to order.



Fully Recyclable

Size	Base Dimensions (w x h x d mm)	O/A Height (mm)	Pack Quantity	Weight (kg)	Order Code
1/3 A4 (DL)	100 x 18 x 84	220	2	0.32	SWBASE1/3A4 + BHV100MH
			10	1.1	
A5	148 x 18 x 84	218	2	0.4	SWBASEA5 + BHV150MH
			10	1.6	
A4	210 x 18 x 84	313	2	0.6	SWBASEA4 + BHV210MH
			10	2.6	



Simply grip the base open and insert the sleeve.

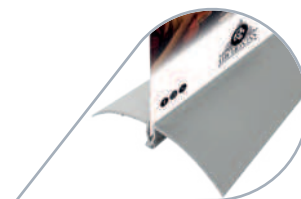

Spring powered grip action bases clamp the insert.

Grip-Action Bases

Spring powered bases – open by hand, insert panel and release.



- Aluminium with silver anodised finish as standard.
- Spring powered grip-action – simply open by hand, insert sleeve and release.
- Holds almost any rigid materials up to 4mm thick.
- Can be branded using self adhesive vinyl, polydome 3D stickers or pad printed graphics.
- Maximum pad printed height 14mm (minimum order quantity 50).
- Custom sizes, colours and finishes available made to order (minimum order quantity 100).
- Take a look at our Grip Chalkers (see page 176) and Grip Talkers (see page 172) for base and panel finished product options.



Fully Recyclable

Size	Base Dimensions (w x h x d mm)	Weight (kg)	Order Code
1/3 A4 (DL)	100 x 18 x 84	0.5	SWBASE1/3A4
A5	148 x 18 x 84	0.8	SWBASEA5
A4	210 x 18 x 84	1	SWBASEA4



Simply grip the base open and insert the panel material.

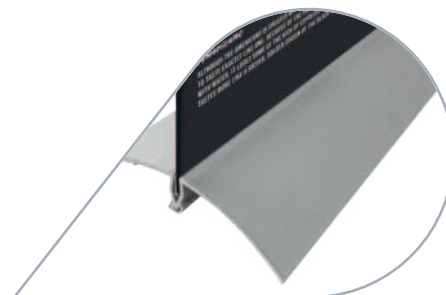

Powerful grip-action.

Interior Leaflet Dispensers

Freestanding crystal clear injection moulded styrene leaflet holders in a wide range of stock sizes.



- Great prices on mass produced lines – 1/3 A4, A5 and A4 single compartment dispensers.
- Custom branding available made to order (minimum order quantities apply).
- Available printed (minimum order quantity 100).
- Additional wall-mounted models (see page 154).

Single Compartment

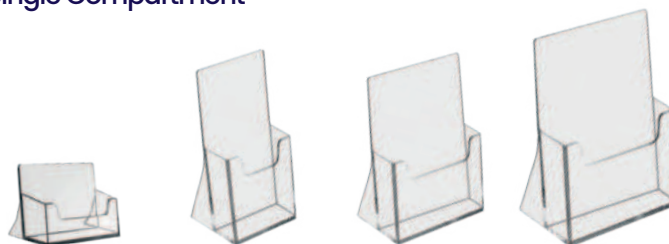

Business Card
freestanding

1/3 A4
freestanding

A5
freestanding

A4
freestanding



Fully Recyclable

Description	Opening Size (mm)	O/A Dimensions (mm)	Pack Options	Order Code
Business Card freestanding	95 x 20	95 x 55 x 39	10/40	BUSCRDH
1/3 A4 freestanding	109 x 32	113 x 198 x 83	4/50	CT110BH
A5 freestanding	160 x 32	164 x 198 x 83	4/40	CT160BH
A4 freestanding	220 x 32	224 x 291 x 96	4/20	CT230BH
2 x 1/3 A4 side-by-side freestanding	112 x 32 (x2)	233 x 249 x 85	2/36	BH2C112
2 x 1/3 A4 stacked freestanding	110 x 42 (x2)	115 x 270 x 120	2/32	BH2C110
4 x 1/3 A4 stacked freestanding	110 x 32 (x2)	115 x 255 x 150	2/20	BH4C110
4 x A4 portrait stacked freestanding or wall mounted	230 x 32 (x4)	236 x 340 x 175	2/8	BH4C230
4 x A4 landscape stacked freestanding or wall mounted	336 x 32 (x4)	340 x 345 x 175	1/8	BH4C330



Multi Compartment



2 x 1/3 A4
side-by-side freestanding



2 x 1/3 A4
stacked freestanding



4 x 1/3 A4
stacked freestanding



4 x A4 portrait stacked
freestanding or wall mounted

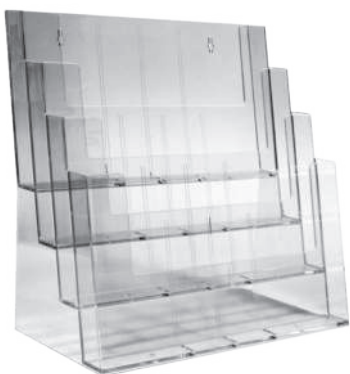
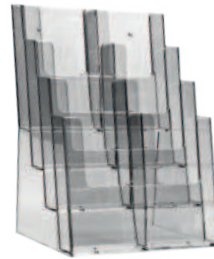

4 x A4 landscape stacked
freestanding or wall mounted



Dividers included for alternative compartment configurations:

4 x A5 landscape, 8 x 1/3A4 (DL) or mixed display combinations e.g. 2 x A4 with 4 x 1/3A4 (DL).

Dividers included for alternative compartment configurations:

8 x A5 portrait, 12 x 1/3A4 (DL) or mixed display combinations e.g. 4 x A5 with 6 x 1/3A4 (DL).

Grip Chalkers

Table top chalkboards featuring our spring powered Grip-Action Bases.



Recyclable: aluminium base, steel springs

Size	Base Dimensions (w x h x d mm)	O/A Height (mm)	Display Area (mm)	Weight (kg)	Order Code (pack of 2)
A5	148 x 18 x 84	222	148 x 201	2.2	HPLTABLECHALKA5 + SWBASEA5
A4	210 x 18 x 84	309	210 x 288	3.8	HPLTABLECHALKA4 + SWBASEA4

HPL Chalkboard Panels

- 3mm High Pressure Laminate with round tops as standard.
- Suitable for traditional chalk and Liquid Chalk Pens (see page 105).
- Square top, custom shape or handle cut out panels available made to order.
- Direct to surface print available.

Bases

- Aluminium with silver anodised finish as standard.
- Spring powered grip-action - simply open by hand, insert panel and release.
- Suitable for self-adhesive vinyl, polydome stickers or pad-printed graphics.
- Maximum pad printed height 14mm (minimum order quantity 50).
- Custom base sizes, colours and finishes available made to order (minimum order quantity 100).
- These bases are suitable for almost any rigid sheet material between 1-4mm thick. E.g. acrylic, PVC, PET and foam PVC.
- Bases can be purchased separately - see page 173.



Spring powered grip-action bases.



Grip the base open and insert the chalkboard.



Pad printed bases available.

Counter/Table Top Chalkboards

Traditional, high quality chalkboards with hardwood bases.



- 3mm High Pressure Laminate chalkboard panels, suitable for vinyl application, traditional chalk and Liquid Chalk Pens (see page 105).
- Hardwood (beech) base.
- Supplied in pairs, fully assembled and ready to use.
- Square top and custom shaped panels available made to order with optional handle cut outs.
- Direct to surface printed panels available made to order.

Available in 3 stock sizes



 No tools assembly

Display Area (mm)	148 x 200	210 x 287	297 x 410
O/A Dimensions (w x h x d mm)	148.5 x 221 x 69	210 x 308 x 69	297 x 431 x 69
Weight (kg)	0.27	0.49	0.85
Base Colour	Walnut	Medium Oak	Walnut
Order Code (pack of 2)	CTCHALKA5	CTCHALKA4MO	CTCHALKA3

Metal Display Card Holder

Available in 2 finishes and 2 height options.



- Choice of black and polished stainless steel (stainless steel is food hygiene safe).
- Single point spring grip card holder suitable for variable card shapes and sizes.
- Suitable for rigid materials up to 1mm thick.
- Low cost and easy to wipe clean.
- Ideal card display size is 89 x 51mm.
- Minimum order quantity 10.
- Printed cards available.

 Fully Recyclable



Also available in black.

Height	O/A Dimensions (w x h mm)	Weight (kg)	Colour	Order Code
100mm	68 x 100 x 80	0.03	Stainless Steel	DCHOLDER100SS
		0.04	Black	DCHOLDER100BC
200mm	68 x 200 x 80	0.04	Stainless Steel	DCHOLDER200SS
		0.05	Black	DCHOLDER200BC



Table Numbers/ Table Signs

Stackable shatterproof signs for table numbers or promotional messages.



- Smooth wipe clean high-strength shatterproof 3mm PETG.
- Reverse printing ensures rich depth of colour and protects appearance when in use.
- Nesting tent card format ensures stability and allows stacking for compact storage.
- 33mm numeral height provides a 10 metre+ visibility range.
- Two standard sizes (w x h x d): 80 x 205 x 125mm and 80 x 315 x 125mm.



Taller 315mm height option for increased visibility.



Stackable for compact storage.

 Made to order



205mm height option shown

Indoor
Counter/Table/Shelf

Bar Runners

Prime positioning for brands at the point of purchase.



Washable



- A premium Bar Runner with highly absorbent knitted polyester textile display surface on a lay-flat rubber backing.
- Stunning definition and colour reproduction.
- Easy to clean – wipeable and washable at 30°C.
- Protects counter-tops.
- 100% recyclable.
- Minimum order quantity 10.
- Custom sizes and shapes available (minimum order quantity 500).



Fully Recyclable

Standard Sizes

600 x 190

434 x 234

894 x 244

Dimensions include 12mm black low-profile border.



Counter Mat

Capture prime advertising space at the counter or reception desk.

- An adhesive-free 1.5mm gloss white 'soft' PVC promotional counter mat.
- Unique stay-flat, non-slip characteristics with added functionality.
- Sometimes referred to as a Cheque Mat, it offers the perfect surface on which to complete forms or sign documents with a ball-point pen.
- Captures prime advertising space at the counter or reception desk - within retail, hospitality, banks, travel agents, car rental, service outlets, etc.
- Long lasting and easy to clean.
- Custom made in a choice of size and shapes. A popular size is 297 x 200mm.

 **Made to order**



Cling-grip underside provides non-slip positioning on all counter surfaces.



Brand Blocks

Stylish and highly effective brand promotion.

- Establish quality brand presence in store.
- Ideal for window displays, counters, desks and shelves.
- All blocks are cut to size in high quality crystal clear acrylic.
- Blocks are printed on the reverse face to achieve characteristic visual depth.
- All blocks are diamond edge polished for optimum clarity from every angle.
- Available in block thicknesses of 20, 25, 30mm.
- All sizes and designs are made to order.



Fully Recyclable



Wobbler

Simple and effective at getting noticed and prompting impulse purchases.



- Sometimes referred to as a Shelf Wobbler or Display Wobbler.
- Ideal for offer promotions or highlighting product features/benefits.
- Printed on 220 micron gloss white PVC for mounting to a clear 240 micron clear PVC 'wobbler' arm.
- Wobbler arm complete with self-adhesive pad at each end for quick assembly and fixture attachment.
- Graphic size/shape typically within 100 x 123mm overall to suit a 150 x 14mm wobbler arm.
- Custom sizes available made to order.



Fully Recyclable



Indoor
Counter/Table/Shelf

Ice Cream Holders

Available in a range of sizes.



Acrylic



Aluminium

- Choice of white aluminium or clear acrylic.
- Choice of sizes.
- Optional self-adhesive non-slip bumper feet.
- Easy wipe/clean surface.
- Openly display food to encourage impulse purchases.
- Custom coloured aluminium available made to order (minimum order quantity 15).

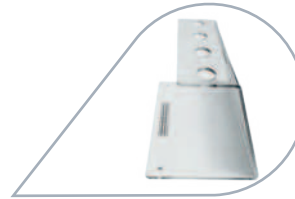

Shaped holes available; oval-hole example above for 'Ice Pop' display.

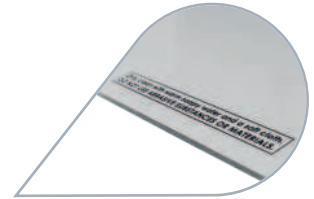

Option to incorporate 'best practice' cleaning messaging.



Fully Recyclable



Multi-Cup Display

Ideal for drink brands.

- Effective point of sale display. Informative and visually appealing.
- Precise cut-outs tailored to cup or drinks dispenser. Could suit other products/markets.
- High impact polystyrene – lightweight and easy to clean.
- Made to order, minimum order quantity 25.

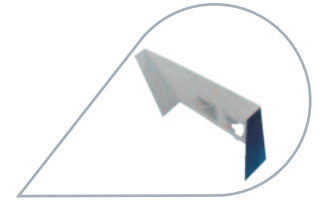

Rear integrated struts offer stability and set optimised viewing angle.

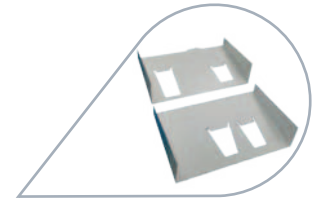

Custom-cut apertures to receive each unique shaped item.



Fully Recyclable



Pivot Grippers

Showcard mounting – ideal for chillers, product displays, shelving gondolas and counters.

- Simply stick to any smooth surface, insert your promotional material and angle as desired.
- Creates a show card position on any horizontal or vertical mounting surface.
- Clear polycarbonate design ensures nothing spoils the view of your showcard or product information.
- Accepts card and other sheet materials between 0.8 and 2mm thick.
- Strong 3M self adhesive mounting pad sticks reliably to varied smooth surfaces.
- Adjusts 190 degrees through 10 positions for the very best display angle.
- Sold in packs of 20.
- For a complete solution we would be delighted to quote for your printed showcards too (minimum order quantity 10).

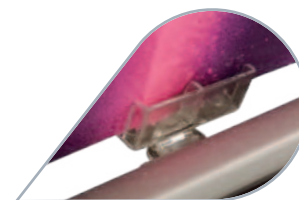

View from the front.

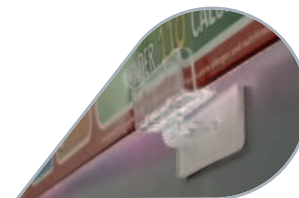

Vertical mounting at the rear.

Range of angles.

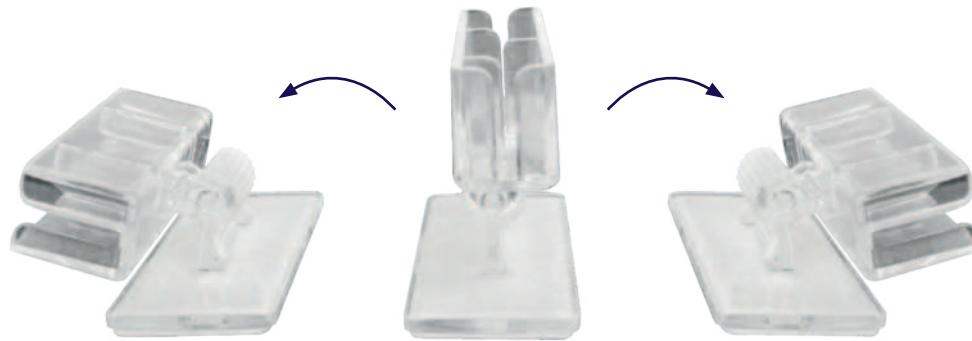
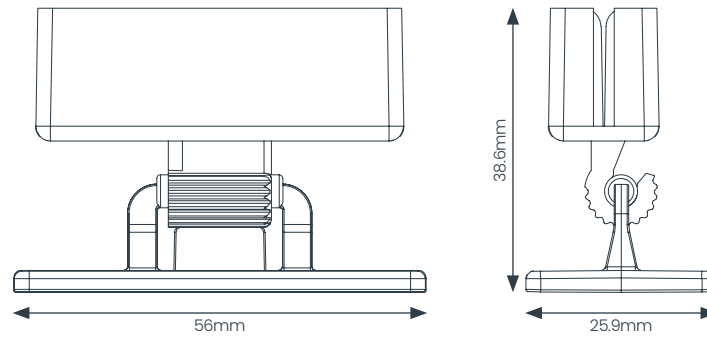

190 degree range of display angles.

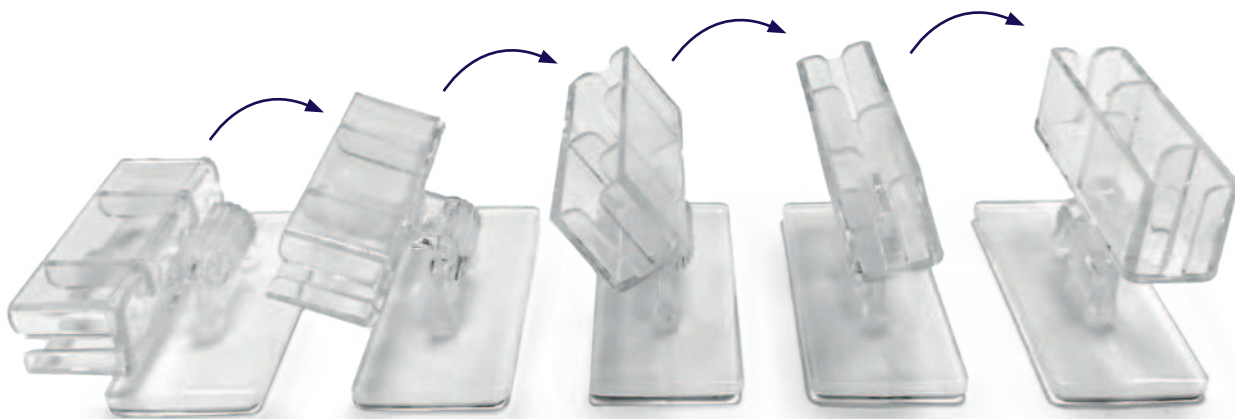

Range of display angles with click-stop positioning .



Print Services, Printed Posters and Printed Backlit Poster Films

Printed advertising materials are as relevant today, in our world of fragmented digital marketing, as they have ever been. Whether on the printed page or a shop front sign, banner or window sticker, print is reassuring, tangible, credible and engaging, and remains an excellent way to establish and reinforce your brand.

When it comes to applying this to point of sale, events or exhibition graphics, and in particular to longer-life outdoor-durable applications, we are masters at the art.

In addition to the branding that is applied to the majority of the products in this brochure we also offer outdoor durable Printed Posters and have recently introduced high quality Printed Backlit Poster Films, sometimes referred to as a 'Duratrans', for absolutely stunning illuminated promotion indoors and out. There is more information on Printed Posters and Printed Backlit Poster Films at the end of this section.

Our Print Capabilities

From our 67,000 square foot production facility, we offer screen, digital and dye-sublimation print supported by a variety of finishing processes.

Despite the rise of digital print technology, our screen printing department is as busy as ever. These two print processes very much complement one another to offer customers the best of both worlds.

The inks we use across all processes are generally eco-friendly water-based and UV cured, offering a minimum of 2 years of outdoor life. An extended life of 5+ years can be achieved from solvent based screen inks for more permanent signage installations.

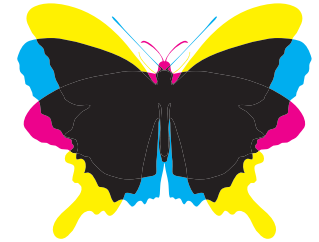

Colour Management

As part of our ISO quality management system we operate advanced ColourServer and SmartProfiler colour management to standardise colour profiles and printer calibrations for different output devices. Although fairly common in the off-set/litho print media sector, systems such as this are far less common, but no less important, for large format and digital print.

The benefit to our customers is:

- Consistent colour reproduction across different medias and outputs.
- Improved quality – such as optimised matching of Pantone colours from CMYK/mixed colour digital output.
- The system is also used to calibrate monitors in our artwork department allowing us to produce reliable visual representations of artwork files for proofing and production checks.



Varnish Over-Print

Although varnish is not essential, we sometimes recommend it for signage intended for outdoor use. As digital print is naturally matt, the finish is more inclined to attract dirt which can dull the image.

Benefits of varnish include:

- Enriched colour vibrancy and depth.
- Added protection from dirt and atmospheric pollution.
- Will help to repel dirt and keep the print looking brighter longer.
- Improved scuff and scratch resistance.
- Improved resistance to chemicals and solvents.
- Adds gloss.



Digital Printing

Some of the benefits of digital print:

- Full-colour photographic images
- High definition close-up viewing
- One-offs/short runs and sampling
- Printing onto uneven/textured surfaces
- Multiple/variable designs in a run

Digital printing offers faster turn-around and lower cost than screen on smaller runs because set-up times are minimal. Your digital artwork files once checked are ripped to one of our flat-bed or roll-fed printers which print all colours in a single pass. We control output definition and ink percentage depending on intended use or viewing distance.

Our state of the art flat-bed printers are able to offer a variety of finishes including spot varnish. For further details talk to our sales team.

It is very common for us to print a mixture of digital and screen processes to optimise the result and to produce the perfect reproduction of a customer's artwork. Digital is added for full colour elements and screen to add spot Pantone colours and/or varnish.



Screen Printing

Some of the benefits of screen print:

- Precise Pantone or spot colour matching.
- Bold, vibrant colours and text due to thicker ink deposits.
- Adding varnish to screen or digital prints to enrich colour, add gloss and increase protection.
- Simple spot or line colour designs.
- Extended outdoor life.

Screen is not suited to short runs. Artwork has to be colour separated from which a separate film and screen stencil is produced resulting in what can be prohibitive origination/set-up costs.

We manage artwork files and colour separations in-house and produce our own films and screens which keeps costs to a minimum.



Dye-Sublimation

Textile & fabric printing.

Unlike other printing techniques that layer ink onto a surface, dye-sublimation forces the ink to penetrate into the material by use of heat - a heat fixation process. It is used widely and especially for textiles (soft signage) to produce flags, banners and retail/exhibition graphics.

Benefits of dye sublimation:

- Highly scuff resistant as a result of being fixed into the media.
- Produces graphics on textiles that can be washed and folded without fear of damage.
- On thinner fabrics it produces excellent show-through. Although a mirror image on the reverse it is ideal for the likes of double-sided Flying Banners, producing a colour vibrancy on the rear that can be impossible to distinguish from the front.



Printed Posters

We offer a competitive, fast turnaround printed poster service on quantities from one!



- Premium matt white 185mic/155gsm polypropylene poster film.
- Competitively priced outdoor poster solution.
- Waterproof, tearproof and highly durable.
- Ideal for indoor and minimum 3 – 6 month outdoor use.
- Exceptional print quality.
- All common poster sizes available.
- Custom sizes available.

For a small additional cost posters can be preloaded in your sign or poster frame prior to despatch. Please call our sales team for more information.

Paper Sizes:

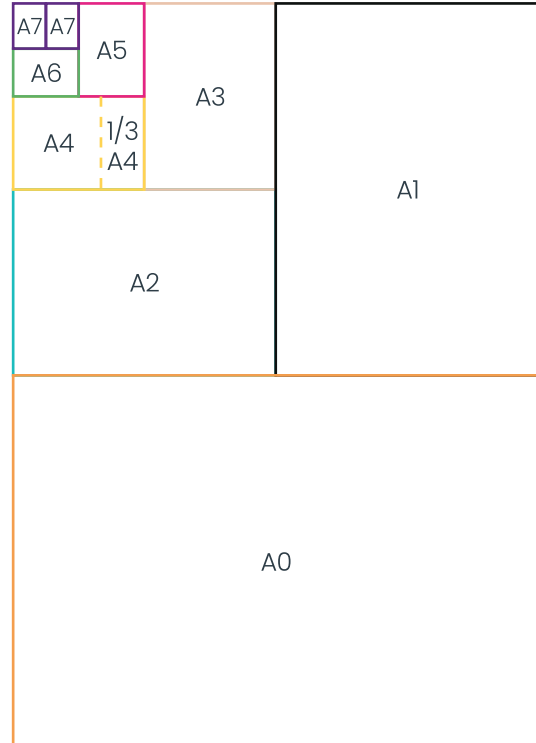



Printed Backlit Poster Films

Sometimes referred to as a Duratrans or Lightbox Poster these are stunning translucent printed film inserts for 'backlit' lightboxes. The optimised combination of media film, print definition and ink saturation delivers stand-out illuminated graphics of the highest quality.



- Ideal for lobby/reception, menu display, trade outlets, showrooms, shopping malls, airports/duty free, motorway services, casinos, cinemas, restaurants and takeaways, museum and gallery, retail stores, trade show exhibit halls, etc.
- Perfect for lifestyle photos in luxury goods promotion.
- Circa 200 micron polyester film with special diffusion coating.
- Indoor and outdoor film options – both durable, lay-flat and tear resistant.
- Standard and custom sizes up to 1365 x 1800mm (includes 6 sheet).
- Environmentally friendly solvent-free print.

Note – Printed Backlit Poster Films will appear darker than normal, only showing their true colours, definition and brilliance once illuminated from behind.



Perfect with our range of edgelit lightboxes.

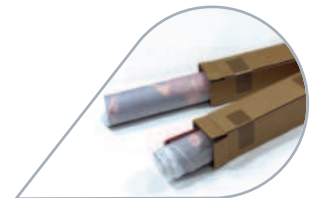

Interleaved, rolled and packed up to 5 to a carton as standard.

 **Made To Order**



Outdoor Poster Materials

To ensure best performance against condensation/moisture ingress in outdoor poster advertising, we recommend:

When it comes to outdoors, however good a frame, display or sign holder is at protecting a poster from the weather, the poster media needs to be moisture resistant at the very minimum to help protect it from dampness in the air and worse the soaking that can take place due to condensation.

For short term (up to 3 months) use outdoors, water or moisture resistant paper, sometimes referred to as 'wet strength' paper, should be fine. It is commonly used for pasted billboard advertising.

For longer term use we would recommend synthetic paper, sometimes referred to as 'poly poster', or a plastic film media with appropriate UV and moisture resistant qualities. Laminating paper both sides in a plastic film (encapsulation) is an option but will be expensive in relative terms.

The matt white polypropylene film we use for all our outdoor posters, for short term applications too, offers excellent performance and is competitively priced, even when compared to moisture resistant paper medias.



7 top artwork tips:

- Always make sure that there is ample space around text and images – adhere to safe areas.
- Use High Resolution settings (300dpi) or Vector artwork for maximum quality.
- Utilise complementary colour schemes for inspiration.
- Embed your fonts for accurate reproduction.
- Proof your document thoroughly.
- Convert your graphic to CMYK (leave spot/pantone colours available in your artwork if used).
- Reduce heat absorption (solar gain) on outdoor poster signs by limiting regions of dark colour print.

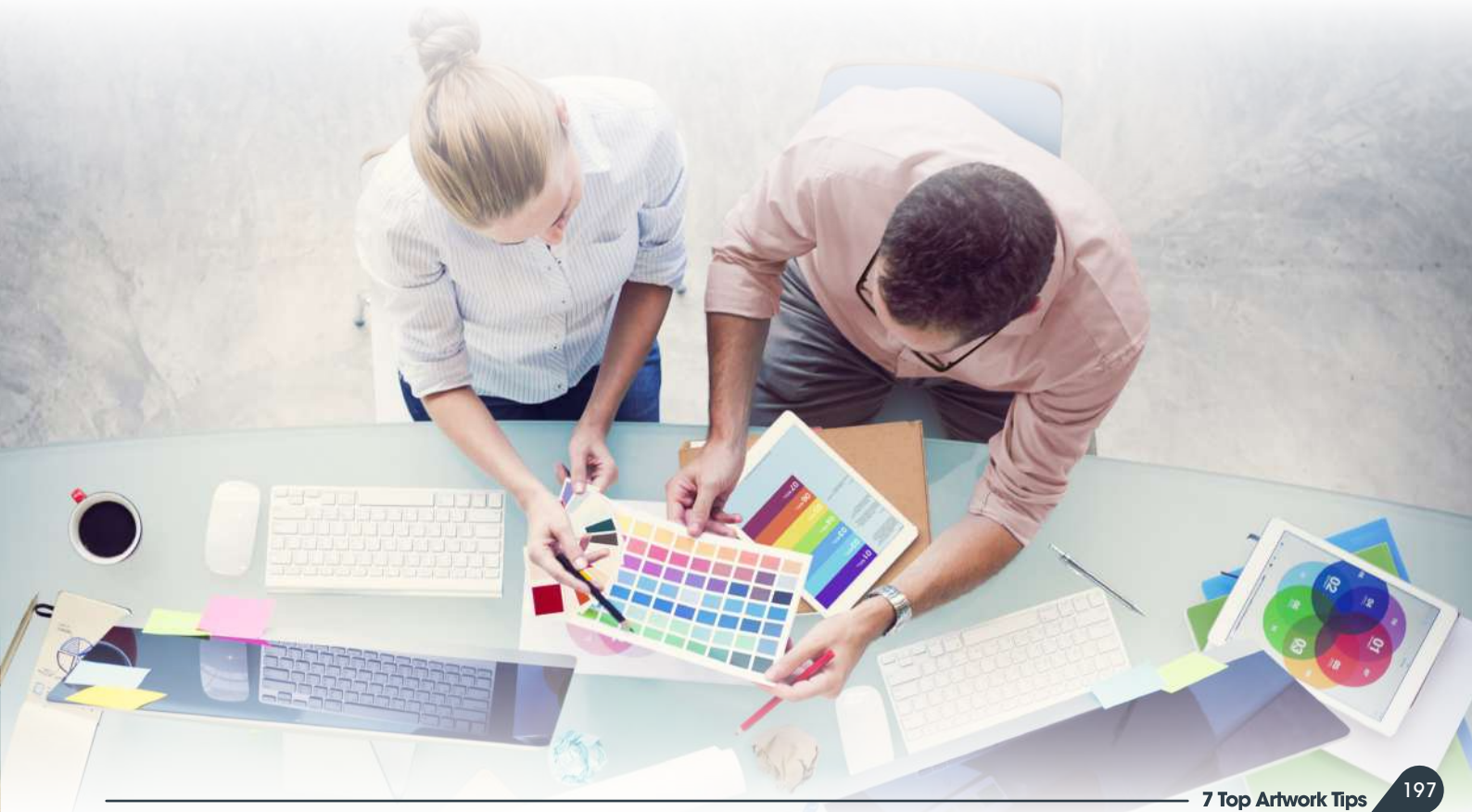

Print Product Overview

Bar Runners

See Page 180



Table Numbers/ Table Signs

See Page 179



Stickers/Labels/Window Graphics

See Page 107



Feature Floor Mat

See Page 141



External Banner

See Page 98



Dealer/Stockist Signs

See Page 80



Open/Closed Signs

See Page pages 144 and 145



Brand Blocks

See Page 182



Counter Mat

See Page 181



Sign Covers

See Page 37



Printed Posters

See Page 192



Printed Backlit Poster Films

See Page 194



Wobbler

See Page 183



Basket Liners

See Page 140



Bollard Wraps

See Page 49



Sigtac® Self-Adhesive Floor Graphics

See Page 76



Accessories & Spares





Image	Product	Colour	Size	Order Code
	Swinger Aluminium Panels for screen/digital print or vinyl graphics	White	430 x 625mm (Eco Swinger)	ECOPANWPAC
			500 x 750mm (Swinger 2)	SWI2PWPAC
			588 x 917mm (Swinger 3000)	SWI3PWPAC
			674 x 997mm (Swinger 4000)	SW4KALIPANPAC
	Swinger Poster Pockets (top-opening) with printed border and magnetic closure (polycarbonate)	White border	281 x 404mm (A3, Eco Swinger)	ECOSWPSTPACW
		Black border		ECOSWPSTPACB
		White border	500 x 750mm (A2, Swinger 2)	SWING2PSTPACW
		Black border		SWING2PSTPACB
		White border	588 x 917mm (20" x 30", Swinger 3000)	SW3KWPSTPAC
		Black border		SW3KBPSTPAC
		White border	674 x 997mm (A1, Swinger 4000)	SW4KWPSTPAC
		Black border		SW4KBPSTPAC
	Swinger 3000/4000 Base	Black	688 x 116 x 600mm	H3BASEBLACK (INC PLUG)
	Panel Hanger for Eco Swinger and Swinger 2 (pack of 2)	Black	21 x 60 x 42mm	ECOSWDFLEX3REPKIT
	D-Flex Panel Hanger for Swinger 2000, 3000 and 4000 (pack of 2)	Black	15 x 44 x 54mm	SWIDFLEX2REPKIT
	Tactical Header Clip for Swinger 3000, 4000 and Sentinel*	Black	25 x 52 x 60mm	SWINGERCLIP01
	Tactical Header Clip for Eco Swinger, Swinger 2, Sightmaster 3 and Spring Sign	Black	46 x 48 x 35mm	SWINGERCLIP02











Image	Product	Colour	Size	Order Code
	Eco Swinger Tactical Header	White	480 x 178mm	THECO
	Swinger 2 Tactical Header		542 x 197mm	THSWING2
	Swinger 3000 Tactical Header		629 x 231mm	TH3000
	Swinger 4000 Tactical Header		716 x 230mm	TH4000
	A1 Sentinel® Tactical Header		625 x 200mm	THSENA1
	30" x 40" Sentinel® Tactical Header		795 x 215mm	THSEN34
	A0 Sentinel® Tactical Header		870 x 230mm	THSENA0
	40" x 60" Sentinel® Tactical Header		1050 x 245mm	THSEN46
	A1 Sightmaster 3 and Spring Sign Tactical Header		582 x 200mm	THSM3A1
	30" x 40" Sightmaster 3 Tactical Header		751 x 215mm	THSM334
	A0 Sightmaster 3 Tactical Header		829 x 230mm	THSM3A0
	Ecoflexlite Panel (Aluminium) for digital/screen print or vinyl graphics.		410 x 795mm	ECOFLITEPANPAC
	Ecoflex 2 Panel (Aluminium) for digital/screen print or vinyl graphics.	460 x 850mm	ECOFLEX2PANPAC	
	Ecoflexextra Panel (Aluminium) for digital/screen print or vinyl graphics.	540 x 952mm	ECOFLEXTRAPANPAC	

Image	Product	Colour	Size	Order Code
	Ecoflex 2 HPL Panel for chalk and liquid chalk pens. Can only be used in bases designed for 3mm thick panels	Black	460 x 850 x 3mm	ECOFLEX2HPLPAC
	Ecoflextra HPL Panel for chalk and liquid chalk pens. Can only be used in bases designed for 3mm thick panels		540 x 942 x 3mm	ECOFLEXTRAHPLPAC
	Twisted Rope	Red	1.5 m (L) x 30mm (dia.)	CBBTROPRED
		Black		CBBTROPEBLACK
		Blue		CBBTROPEBLUE
	Poster Cover Sheets for Snapframes, A-Master, Sightmaster 2 and 3 and Spring Sign (anti-glare 500 micron PET)	Clear	A2 poster (420 x 594mm)	PET420594
			20" x 30" poster	PET508762
			A1 poster (594 x 841mm)	PET594841
			30" x 40" poster	PET7621016
			A0 poster (841 x 1189mm)	PET8411189
			40" x 60" poster	PET10161524
	Poster Cover Sheets for Defender (anti-glare 500 micron PET)		30" x 40" poster	PET1028762
	40" x 60" poster		PET15461036	
	Poster Cover Sheets for Cyclone 2 (gloss clear 700 micron PET)		40" x 60" poster	PET10161536700M
	Magnetic Poster Cover Sheets for Informer and Booster (anti-glare 500 micron PET with printed border)	White border	A2 (420 x 594mm)	INFA2CWPAC
		Black border		INFA2CBPAC
		White border	20" x 30"	INF2030CWPAC
		Black border		INF2030CBLKPAC
		Silver/grey border		INF2030CSPAC
		White border	A1 (594 x 841mm)	INFA1CWPAC
		Black border		INFA1CBLKPAC
	Sentinel® Poster Cover Sheets (polycarbonate) with silver printed magnetic border, fixings and Allen key	Clear	30" x 40"	SEN34MK4PANEL
			A0 (841 x 1189mm)	SENA0MK4PANEL
			40" x 60"	SEN46MK4PANEL

Image	Product	Colour	Size	Order Code
	Self-Adhesive Magnetic Tape (A)	-	12mm x 30m	TAP0006
	Self-Adhesive Magnetic Tape (B)			TAP0043
	Self-Adhesive Steel Tape	-	12mm x 30m	TAP0007
	Narrow Double-Sided Foam Tape	White	12mm x 1.6mm x 50m	TAP0014H
	Wide Double-Sided Foam Tape	White	32mm x 1mm x 60m	TAP0052
	Graphia® Roller Banner Connectors (for Graphia® Roller Banners)	Black	-	RBDSC
	Trolley (for various forecourt signs)	Silver	225 x 1220 x 225mm	TROLLEY
	Adaptor (req'd only for Sightmaster 2)	Silver	90 x 45 x 48mm	TROLLEYADAPTOR
	Hose (for filling water-fill bases)	Black	3000 x 13mm	SENHOSE
	Opening Tool for Security Snapframes	Grey	Length: 113mm	SFS0T01
	Concrete Bases for Defender	Grey	600 diameter for 30" x 40" (53kg)	KIT01
			800 diameter for 40" x 60" (80kg)	KIT02
	Magnetic Pins for Slimlok Noticeboard, Menu Case and Illuminated Menu Case (set of 8)	White	16mm (H) x 12mm (dia.)	MAGPINSETS
	LED Power Supply for all single-sided Lightboxes and Menu Cases. Not suitable for use with Lockable Weatherproof Smart LEDbox. (12 volt/6 amp power rating for interior use)	Black	130 x 55 x 32mm	LEDPS1
	12 volt Extension Cable for Slimlok Illuminated Menu Case, Edgelit XT, D-Light & Best Buy LEDbox	Black	3m	3000MM ADD ON LEAD
	240 volt Extension Cable for Lockable Weatherproof Smart LEDbox	Black	2m - Internal Use	2000MMCABLEINT
	12 volt Extension Cable for Lockable Weatherproof Smart LEDbox		2m - External Use	2000MMCABLEEXT
	Cable Hanging Kit - for ceiling	Silver	2m	CABLEKITC
	Cable Hanging Kit - for ceiling and wall	Silver	2m	CABLEKITW
	3mm High Pressure Laminate Chalkboard Panels for Premier A-Boards and and Premium Reversible Chalk A-Boards by Woodworkz®	Black	Small: 563 x 813 x 3mm	HPLPREMBOARDSM
			Large: 730 x 1049 x 3mm	HPLPREMBOARDLG3MM
	5mm Foam PVC Panels for Premier A-Boards	White	Small: 563 x 813 x 5mm	FOAMPREMBOARDSM5MM
			Large: 730 x 1049 x 5mm	FOAMPREMBOARDLG5MM
	3mm Aluminium Composite Material Panels for Premier A-Boards and Premium Reversible Chalk A-Boards by Woodworkz®	White	Small: 563 x 813 x 3mm	ACMPREMBOARDSM3MM
			Large: 730 x 1049 x 3mm	ACMPREMBOARDLG3MM







Image	Product	Colour	Size	Order Code
	Supports for Woodworkz® Easel (pair)	Country Oak	35mm (dia.) x 30mm (ea.)	KNOBCO35PAIR
	Chalk Insert Panels Turn virtually any poster frame/holder into a chalkboard	Black	A2 (420 x 594mm)	INFA2CCB
			20" x 30"	INF2030CCB
			A1 (594 x 841mm)	INFA1CCB
	Chalk Pens	Assorted	5 x 5mm nib (small)	CHALKPENSET1
		White	3 x 15mm nib (large)	CHALKPENSET2
		Assorted	5 x 15mm nib (large)	CHALKPENSET3
	Grip-Action Bases for Grip Chalkers and Grip Talkers	Silver	1/3 A4 (99 x 210mm)	SWBASE1/3A4
			A5 (148 x 210mm)	SWBASEA5
			A4 (210 x 297mm)	SWBASEA4
	Cross Base for Flying Banners	Grey	840 x 60mm	FBBASE(2)
	Water Bag for Flying Banners (use with Cross Base)	Grey	540mm (dia.)	FBBAG(H)
	Ground Spike for Flying Banners	Silver	500mm	FBSPIKE(2)
	Wheel Base for Flying Banners	Black	480 x 35 x 520mm	FBWHEEL(2)
	Concrete Base for Flying Banners (with bearing spindle)	Grey	600mm (dia.) x 100mm (H) (67kg)	FBCONC + FBCONCBRG

Image	Product	Colour	Size	Order Code
	Small Tank Base with spindle	Black/Chrome	455 x 245 x 455mm	FBSMTK+TKBRG
	Large Tank Base with spindle	Black/Chrome	584 x 280 x 584mm	FBLGTK+TKBRG
	Spindle only	Chrome	100 x 132 x 100mm	TKBRG
	Base Plate for Flying Banners	Black	Small 300mm (L) 300mm (W) 9mm (H) (plate 6mm thick)	FBBASEPLATESM
			Large 400mm (L) 400mm (W) 9mm (H) (plate 6mm thick)	FBBASEPLATELG
	Surface Mount Spindle and Bracket for Flying Banners	Black/Chrome	100 x 132 x 100mm	FBCONCBRG
	Vertical Wall Mounted Bearing Spindle for Flying Banners	Black/Chrome	100 x 155mm	FBVERTWALBRG
	Angled Wall Mounted Bearing Spindle for Flying Banners	Black/Chrome	100 x 129mm	FB25DGWALBRG
	Parasol Base	White	440 x 150 x 440mm (20 litre)	PARABASE
	Parasol Frame Only	White	Max: 1800 x 2200 x 1800mm	PARAFRAME(ONLY)
	Hard Trolley Case/Counter for Curved Pop- Ups	Black	593 x 890 x 500mm	MPUC
	Counter top	Black	700 x 500 x 8mm	MPUCTT2
	Graphic fitting strips only	Silver	51 x 755 x 6mm	GWSTRIPS
	Graphic Wrap (including fitting strips)	White	1570 x 755 x 0.46mm	MPUCGW
	Carry Bag for Promo Counters	Black	1100 x 900 x 110mm	CONVXBG

Index

A

A-Board.....	32
Accessories & Spares	200
Acrylic & ACM Wall Mounted Information Displays.....	156
Adfresco® Café Barrier Kits.....	68
Adfresco® Café Barrier Selection Tool.....	66
Adfresco® Example Layout.....	73
Adfresco® LT Café Barrier.....	64
Adfresco® Café Barrier.....	63
A-Master.....	13
A-Master Lite.....	14
A-Master Plus.....	15
Artwork tips.....	197

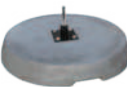
B

Banners.....	98
Banner Frame.....	48
Bar Runners.....	180
Base Plate for Flying Banners.....	57
Basket Liners.....	140
Basket Showcard Holders.....	122
Best Buy LEDbox - Single Sided Lightbox.....	151
Bollard Wraps.....	49
Booster.....	17
Bracket Mount Bearing Spindles for Flying Banners.....	59
Brand Blocks.....	182
Budget A-Board.....	33

C

Cable Hanging Kit.....	203
Café Barriers.....	63
Chalk A-Boards by Woodworkz®.....	46
Chalkboards (Counter/Table Top).....	177
Chalkboards (Framed) - Indoor.....	153
Chalkboards (Framed) - Outdoor.....	103
Chalkboards (Unframed).....	104
Chalk Insert Panels.....	43
Classic Garden Parasol.....	74
Clear Menu Holder.....	169
Colour Management.....	190
Concrete Base for Flying Banner.....	58
Contents.....	2
Conversion Table.....	209

Counter Mat.....	181
Counterstand Snapframes.....	170
Counter/Table/Shelf - Indoor.....	166
Counter/Table Top Chalkboards.....	177
Cross Base and Water Bag for Flying Banner.....	57
Curved Pop-Up.....	130
Custom shape Flange Signs.....	102
Cyclone 2.....	21

D

Dealer/Stockist Signs.....	80
Decorative Brochure Stand.....	132
Decorative Menuboard.....	117
Defender.....	25
Description Of Goods.....	208
Digital Printing.....	191
D-Light.....	152
Dye-Sublimation/Textile & Fabric Printing.....	191

E

Easel Chalkboards.....	113
Easel by Woodworkz®.....	112
Ecoflex.....	26
Ecoflex 2.....	28
Ecoflex 2 Totem & Ecoflexextra Totem.....	31
Ecoflex Chalkboard Panels.....	30
Ecoflex Custom Shaped Panels.....	30
Ecoflex (range overview).....	26
Ecoflexlite.....	27
Ecoflexextra.....	29
Eco Swinger.....	8
Edgelit XT - Single Sided Lightbox.....	150
Extension Cable.....	203
Exterior Leaflet Holders.....	106
External Banner.....	98

F

Feather Flying Banner.....	53
Feature Floor Mat.....	141
Flange Signs.....	102
Flavour/Range Boards.....	81
Flying Banner Bearing Spindle.....	51

Flying Banner Flag Materials.....	52
Flying Banner Flag Pole Sleeves.....	52
Flying Banner Mounting Accessories/Base Options.....	56
Flying Banners.....	50
Flying Banner Selection Tool.....	51
Flying Banner with Base Plate.....	124
Frameworkz Snapframe.....	89
Freelight Plus.....	164
Freestanding/Floor Mounted - Indoor.....	110
Freestanding/Floor Mounted - Outdoor.....	4

G

Giant Pole.....	62
Graphia® Roller Banner.....	126
Graphia® Roller Banner Connectors.....	127
Grip-Action Bases.....	173
Grip Chalkers.....	176
Grip Talkers.....	172
Ground Spike for Flying Banners.....	59

H

Hanging Kit.....	203
Hard Trolley Case/Counter.....	131
Headliner.....	146
Headlinerlite.....	147
High Rise Flying Banner Kits.....	60
Hi-Sight.....	96

I

Ice Cream Holders.....	184
Illuminated Slimlok Menu Case.....	92
Information Displays (wall mounted).....	156
Informer.....	16
Interior Leaflet Dispensers.....	154, 174
i-Stand.....	119

K

Key.....	3
----------	---

L

Leaflet Holders/Dispensers.....	154, 174
Lightbox Poster Display (Indoor).....	150
Lightbox Poster Display (Outdoor).....	94
Liquid Chalk Pens.....	105
Lockable Snapframes.....	88
Lockable Weatherproof Smart LEDbox.....	94

M

Magnetic POS Flag Arm.....	165
Menu Case.....	91
Menu Holders.....	168
Metal Display Card Holder.....	178
Metal Floor Display Stand.....	116
Minimus Snapframes.....	148
Modular Pole Display.....	134
Mounting Accessories for Flying Banners.....	56
Multi-Cup Display.....	185

N

Noscrewz Flag Kit.....	101
Noticeboard.....	93

O

Open/Closed Signs - Flipper.....	145
Open/Closed Signs - Slider.....	144
Our Chalkboard Panels.....	105
Our Print Capabilities.....	190
Outdoor Poster Materials.....	196
Overture Menu Holder.....	168

P

Paper Sizes.....	209
Parasols.....	74
Pivot Grippers.....	186
Pole & Rope Barrier.....	114
Portland Menustand.....	118
Poster Case.....	90
Poster Clamp.....	163
Poster Hanger.....	162
Poster Pillar.....	115
POW! Sign.....	38
Premier A-Board.....	44
Premier A-Board Frame.....	45
Printed Backlit Poster Films.....	194
Printed Posters.....	192
Print Product Overview.....	198
Print Services, Printed Posters and Printed Backlit Poster Films.....	188
Promo Counter Carry Bag.....	205
Promo Counter.....	129

R

Rectangle Flying Banner.....	55
Rollsby Roller Banner	128
Rope.....	202

S

Screen Printing.....	191
Security Snapframes.....	87
Sentinel®.....	22
Sentinel® Banner.....	36
Sentinel® Tactical Header.....	24
Showcard Stands.....	120
Sightmaster 3.....	18
Sightmaster 3 Tactical Header.....	19
Sign Covers.....	37
Sign Nav.....	149
Signtac® Self-Adhesive Floor Graphics	76
Slimlok Menu Case.....	91
Slimlok Noticeboard.....	93
Slimlok Poster Case.....	90
Snapframes (Minimus).....	148
Snapframes (overview).....	82
Spacemaster.....	133
Spring Sign.....	20
Spring Sign Tactical Header.....	20
Standard Flag Kit.....	100
Standard Snapframes.....	83
Stand-Off Sign Fixings.....	108
Stand-Off Sign Fixings Guidance.....	109
Stickers, Labels & Window Graphics.....	107
Straight/Tilt Talkers.....	171
Suspended/Hanging - Indoor.....	160
Swinger (range overview).....	6
Swinger Tactical Header.....	12
Swinger 2.....	9
Swinger 3000.....	10
Swinger 4000.....	11

T

Table Numbers/Table Signs.....	179
Table Top Chalkboards.....	177
Tactical Header for Sentinel®.....	24
Tactical Header for Sightmaster 3.....	19
Tactical Header for Spring Sign.....	20
Tactical Header for Swinger.....	12
Tank Bases for Flying Banners.....	56
Teardrop Flying Banner.....	54

Teardrop Flying Banner (on Angled Wall Bracket).....	95
Tilt Talkers.....	171
Trolley and Hose.....	42
Twisted Rope.....	202

V

Varnish Over-Print.....	190
Viewing Distances.....	209

W

Wall Banner Frame.....	99
Wall Chalkboards (Unframed).....	104
Wall Mounted Information Displays.....	156
Wall/Window Mounted - Indoor.....	142
Wall/Window Mounted - Outdoor.....	78
Waterbase A-Board.....	34
Waterbase Pyramid.....	35
Wheel Base for Flying Banner.....	58
Wobbler.....	183
Woodworkz® Chalk A-Boards.....	46
Woodworkz® Easel.....	112
Woodworkz® Framed Chalkboards (Indoor).....	153
Woodworkz® Framed Chalkboards (Outdoor).....	103

X

X-Banner.....	125
---------------	-----

Description of Goods

Before using any of these products, the customer shall determine the suitability of the product for its intended use, and the customer assumes all risks and liability whatsoever in connection herewith. The supplier shall not be liable either in tort or in contract for any loss or damage – direct, incidental or consequential, arising out of the use of, or the inability to use any of the products.

All specifications, drawings, illustrations, particulars of weight and dimensions issued are approximate only and do not form part of any terms, conditions or warranties of any contract. The supplier may vary such specifications, drawings, illustrations, particulars of weight and dimensions at any time and for whatever reason, without having to give a reason or explanation.

Paper Sizes

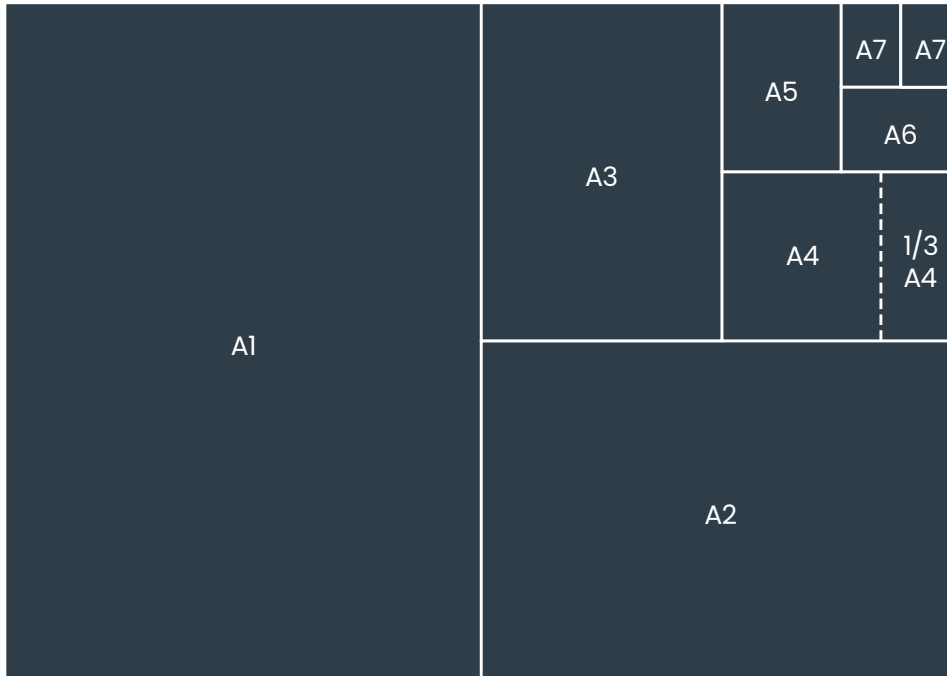

Conversion Table

Size	Millimetres	Inches
A7	74mm x 105mm	2 7/8" x 4 1/8"
1/3 A4	99mm x 210mm	8" x 4 1/4"
A6	105mm x 148mm	4 1/8" x 5 7/8"
A5	148mm x 210mm	5 7/8" x 8 1/4"
A4	210mm x 297mm	8 1/4" x 11 3/4"
A3	297mm x 420mm	11 3/4" x 16 1/2"
A2	420mm x 594mm	16 1/2" x 23 3/8"
20" x 30"	508mm x 762mm	20" x 30"
A1	594mm x 841mm	23 3/8" x 33 1/8"
30" x 40"	762mm x 1016mm	30" x 40"
A0	841mm x 1189mm	33 1/8" x 46 3/4"
40" x 60"	1016mm x 1524mm	40" x 60"

Viewing Distances

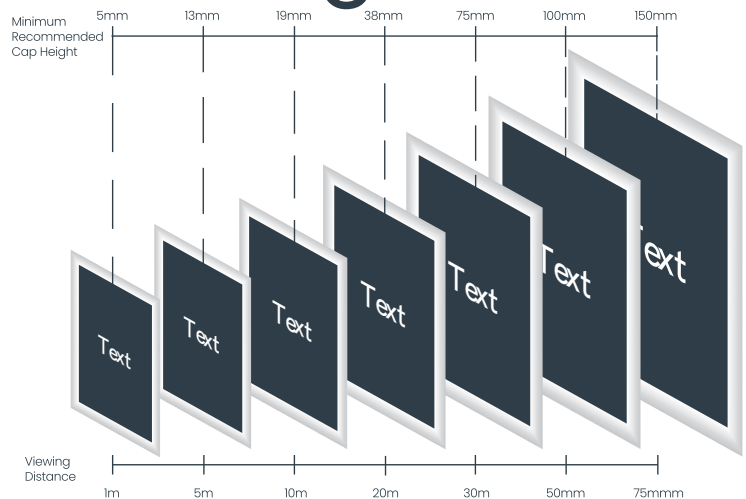



**SIGN
& DISPLAY**
COLLECTION