

# Portable Industrial Tools For Professionals

Exceeding customer expectations since 1977



Drilling Beveling Grinding Sawing Lifting



# **EUROBOOR**

FOR PROFESSIONALS BY PROFESSIONALS

Catalogue - English

# Our mission:

"Exceeding customer expectations by developing and providing safe, premium and innovative portable drilling and cutting solutions."



#### The Netherlands office

Kryptonstraat 110  
2718 TD Zoetermeer  
t +31(0)79 361 49 90  
e [info.nl@euroboor.com](mailto:info.nl@euroboor.com)



#### Brasil office

Rua Harpia 438 Novo Horizonte,  
Serra, 29.163-308  
Espírito Santo, Brasil  
t +55 27 98827 1043  
e [contato.br@euroboor.com](mailto:contato.br@euroboor.com)

#### UAE office

SAIF Zone A2-084  
P.O. Box No: 120085, Sharjah  
t +971 655 784 54  
e [info.uae@euroboor.com](mailto:info.uae@euroboor.com)

#### USA office

160 White Oak Road  
Hayden, AL 35079  
t +1 844 266 85 27  
e [info.usa@euroboor.com](mailto:info.usa@euroboor.com)

#### China office

2nd Floor, HongJi Building, No9#, LiuShi Road,  
LiXiang Village, Tangshi  
Yangshe Town, ZhangJiagang City,  
Jiangsu China 215600  
t +8651258549182  
e [info@euroboorchina.com](mailto:info@euroboorchina.com)

Go to our website  
for more information:  
[www.euroboor.com](http://www.euroboor.com)

Design and lay-out  
VormPro (NL)

This catalogue is for those interested in our company.  
For more information contact us by email or phone.  
No part of this catalogue may be reproduced or copied  
without prior written consent.  
All pictures in this catalogue are meant to give an  
impression. This catalogue has been compiled with the  
utmost care. Nevertheless it is possible that certain  
information included is now outdated or no longer complete.  
Euroboor is not responsible for results of actions taken  
purely on the basis of this catalogue. Euroboor therefore  
recommends seeking our professional expert advice before  
undertaking any actions purely based on the information in  
this catalogue.

 **EUROBOOR**

ISO9001 certified company



# Table of contents

Our vision	4				
Magnetic drilling machines	6				
Features explained	8				
<b>Magnetic drilling machines</b>					
ECO.30S+	11				
ECO.32	12				
ECO.32+	15				
ECO.36+	40				
ECO.40/2+	14				
ECO.40S+	15				
ECO.40S+/P	17				
ECO.50S+	19				
ECO.60S+	25				
ECO.80S+	26				
<b>Tapping capability</b>					
ECO.32-T	13				
ECO.36+/T	41				
ECO.50+/T	18				
ECO.55S+/T	22				
ECO.55S+/TA	23				
ECO.100S+/TD	27				
ECO.100S+/CT	28				
ECO.200S/T	29				
<b>Frame adapter</b>					
F16+	30				
<b>Tube</b>					
TUBE.30	34				
TUBE.55S+/T	35				
<b>Air</b>					
TUBE.55/AIR	36				
AIR.55	37				
<b>Vacuum</b>					
VAC.50S+	39				
<b>Battery powered</b>					
EBM.36/P-18V	42				
<b>Rail</b>					
RAIL.60S	43				
<b>Accessories</b>					
<b>Powerstation</b>					
PST.2500/3	44				
<b>Setup overview</b>					
Weldon	46				
Twist drill	47				
Armature Kit	48				
WeINit Kit	49				
Adapters	50				
Extensions	51				
Connections	51				
Morse Taper reductions	51				
Arbors	52				
Drill chuck connections	53				
Twist drill chucks	53				
<b>Cutting lubricants</b>					
Cutting oils	56				
Sprays	56				
Paste	57				
Gearbox oil	57				
<b>Annular cutters</b>					
Overview	61				
HSS	62				
HSS sets	65				
HSS Stack	67				
HSS-Cobalt	69				
TCT	71				
TCT sets	80				
TCT Rail	82				
ERM.100/3	83				
Pilot pins	84				
Pilot pin recommendations	86				
<b>Drilling tools</b>					
TCT Hole Saw	88				
Weldon twist drills	89				
Countersinks	89				
Twist drills	90				
Step drills	90				
After drilling aid	90				
<b>Tapping tools</b>					
Tapping chucks	91				
Tap holders (Weldon)	92				
Machine taps	92				
Tap and twist drill set	93				
Drill tap combination	93				
Drill tap combination sets	93				
<b>Sets</b>					
Complete overview sets	95				
<b>Beveling tools</b>					
B60	96				
B60S	97				
B45S	98				
BM45AIR	99				
<b>Grinding tools</b>					
EDG.600	100				
ADG.2(A/S/E)	101				
<b>Carbide rotary burrs</b>					
Rotary burrs	102				
<b>Sawing tools</b>					
EDC.355	110				
EBS.500	113				
<b>Battery powered</b>					
EDC.355/36V	112				
<b>Lifting tools</b>					
ELM.125	117				
ELM.250	117				
ELM.500	117				
ELM.1000	117				
ELM.2000	117				
<b>Information</b>					
Service	118				
Euroboor worldwide	119				



# Our vision

**Ever worked with industrial tools which did not deliver on the promised quality and output? Heavy machines which are inconvenient to use and therefore cost both you and your employees a lot of time and effort?**

At Euroboor we believe, ever since our founding in 1977, that it can be done differently. That a professional like you must be able to rely on a professional supplier. Which has led us to become a major player in the industrial world, with our own factory and several offices worldwide. All because we have always listened to our customers and to the demands from the market.

Our customers are the ones who use our tools every day. Therefore they are our key indicators when it comes to the development and production. To which the starting point is clear: good is not good enough! Euroboor always goes one step further. With our

production methods and technical approach, it is our goal to develop lighter, stronger, safer and more reliable tools. In addition, we test our tools thoroughly from the start of the development process all the way up to production.

Our vision is focused on developing innovative portable tools that add value for our customers and facilitate them in their daily work. We never lose sight of safety, sustainability, time & cost savings. Our mission is always clear: exceeding customer's expectations by developing and providing premium and innovative portable drilling and cutting solutions.



**Focus**



**Quality**



**Efficiency**



**Safety**

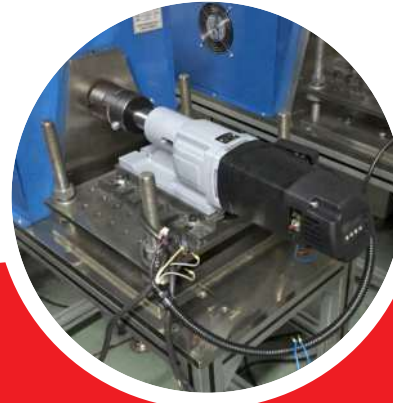

## From development, to extensive prototype testing to producing premium tools

The production of our magnetic drilling machines takes place in our own and highly organised facility where we are able to produce our tools to the highest standards. Having our own facility also means we are able to adapt, evolve and innovate easily and therefore make new developments and tailor-made products available to you quickly.

To be able to develop and provide premium and innovative portable drilling and cutting solutions which exceed our customer expectations we test each and every concept, sample and component to its limits, and beyond. Our own testing facility allows us to extensively test our self-produced prototypes and expose them to all necessary endurance tests.



## Sustainability & Ecological awareness

By continuously updating our production process we are able to shorten production times and minimise usage of raw materials, thus consuming and wasting less material which means we reduce our use of natural resources. The use of virgin, but renewable, raw materials during our advanced manufacturing process helps us to develop lighter, stronger and more reliable and efficient tools. Making their practical use clear: faster and more premium results with reduced operating time. This translates directly into reduced energy use, causing less stress on the environment.

# Euroboor magnetic drilling machines



Our magnetic drilling machines are designed and engineered to the highest standards. With our many years of experience we dare to say that we know what you need. We stay in charge of today's and tomorrow's demands by being active in the field and remaining in close contact with the people that actually use our machines.

We develop, design, engineer and produce our magnetic drilling machines in-house.

We only use the best and most trustworthy suppliers or we roll up our sleeves and produce the required parts ourselves. The same applies for all our drills and cutters.

Every stage in the production process is subjected to stringent durability tests, and pre-shipment inspections are equally meticulous.

Only thus can we ensure you our core values: Efficiency, Focus, Quality, and Safety.

We pride ourselves on our line-up of magnetic drilling machines ranging from small scale fabrication to special purposes and designed to offer you the best possible options. Regardless of your company size, specialism or tasks at hand, you will find the perfect match at Euroboor.



# Safety features explained

## Magnet LED-indicator



The control panel on your magnetic drilling machine is designed for maximum ease of use and safety. Here you can find the magnet LED-indicator. There are two options:



**SENSORTEC**

The LED-indicator lights up **GREEN** when the generated magnetic force is sufficient. You can now safely start your drilling job.

The LED-indicator lights up **RED** when the generated magnetic force is insufficient due to:

- Surface not being flat
- Workpiece not being magnetisable (e.g. aluminium)
- Workpiece is coated or painted
- Workpiece is not thick enough

If resolving the above doesn't help, the magnet doesn't function properly. Don't start your drilling job, but have your machine checked and serviced.

## Gyro-Tec safety



**Gyro-Tec** safety features a gyroscopic sensor which detects acceleration and displacement in any direction.

The **Gyro-Tec** safety feature engages three seconds after the motor is started. Whenever the machine recognises a sudden or unwanted movement the motor will be shut down automatically by the machine's electronics. This safety functionality offers extra protection in various circumstances, such as:

- Sudden loss of magnetic force while in operation
- Excessive vibration caused by incorrect drilling procedure, worn-out cutting tools, etc.
- Sudden displacement of the workpiece to which the magnetic drilling machine is attached

By the motor shutting down automatically, risk of damaging or hurting the machine, tools, workpiece and operator is reduced.

## Integrated motor cable

The frame of your magnetic drilling machine is designed for maximum safety and comfort. It is provided with an ergonomic handle and part of the machines in our portfolio have an integrated motor cable. The machines with integrated cable offer increased safety as the cable is completely incorporated in the frame. This prevents the user from getting caught in the cable and the cable from tearing or snapping off. It also prevents a lot of unnecessary repairs and therefore additional costs because the user can no longer lift and carry the machine by the motor cable, which often happens in practice.



## 2-way magnet



The 2-way magnet saves energy when the machine is not being used. The machine sticks sufficiently at half the magnetic force, this ensures you use less energy. The magnet generates less heat which makes the lifespan of the machine is longer. Only with full magnetic force the machine can be used for drilling.

## Power protection

The power protection feature is two-fold; it consists of both power fluctuation protection and power surge protection. Special safety components built into the electronics of the machine make it more reliable in situations where power supply can be of varying quality due to factors:

- Around the workplace, for example caused by switching on high power or unreliable electrical devices, a broken circuit breaker or faulty wiring
- Outside the workplace, for example caused by an instable power grid or lightning

A machine with this feature is able to cope with standard rated voltage and frequency fluctuations ranging from:

- 110 Volt to 130 Volt and 45 Hz to 65 Hz, or
- 220 Volt to 240 Volt and 45 Hz to 65 Hz reducing the probability of breakdown and minimizing down-time and repair cost.

### Power fluctuation protection



When the frequency is too high (above 65 Hz) or too low (below 45 Hz), the motor will not start. If the frequency of the power supply falls outside the range during your drilling job, the motor will shut off automatically. The machine will work again normally when the normal frequency has been restored.\*

### Power surge protection



Beyond the rated voltage, a machine with this feature is able to cope with voltage spikes up to 4,000 Volt (1-2 $\mu$ s)\*, which could be caused by nearby welding activities. Depending on the height of the spike, it may be necessary to replace built-in fuses, the control unit or the power switch, but other valuable parts like the motor and magnet will be protected.

### Overload protection



To ensure safe use and longer lifetime of the motor the machine profits by overload protection. While you are using the machine there are different types of load levels, which correlate with the feed pressure. Once you go from close to overload to exceeding the overload limit the machine will automatically stop the motor.

### Smart Restart



When the motor is in overload, the **Smart Restart** torque control technology ensures trouble-free continuation of your drilling job. When the feed pressure is reduced, the machine's electronics recognise the reduction and the motor continues within a few seconds.

### Overheat protection



To prevent damage, machines with this feature are equipped with a sensor which will shut off the motor automatically when the temperature of the field coil exceeds 100° C - 105° C.

\*Disclaimer: Euroboor is not liable for any damage caused to the machine due to electrical problems in the workplace. Above mentioned protection is not guaranteed in all cases of voltage spikes and/or frequency fluctuations. Euroboor accepts no liability when it comes to the power protection not functioning or functioning poorly.



## Carbon brushes

The carbon brushes on the magnetic drilling machine are equipped with two protective features. The purpose of both features is to schedule timely service and avoid additional costs by unexpected downtime or unnecessary part replacement.

### Carbon brush wear indicator



On the motor housing you will find an integrated LED light. Under normal circumstances this light is off. The LED light will start burning **RED** when the carbon brushes are worn to a level where it is advised to replace them.

### Automatic shut-off



When the carbon brushes are actually worn to a level where replacement is needed, the motor will be shut-off automatically. This prevents the armature from being damaged. Once shut off, the LED-indicator is no longer lit.

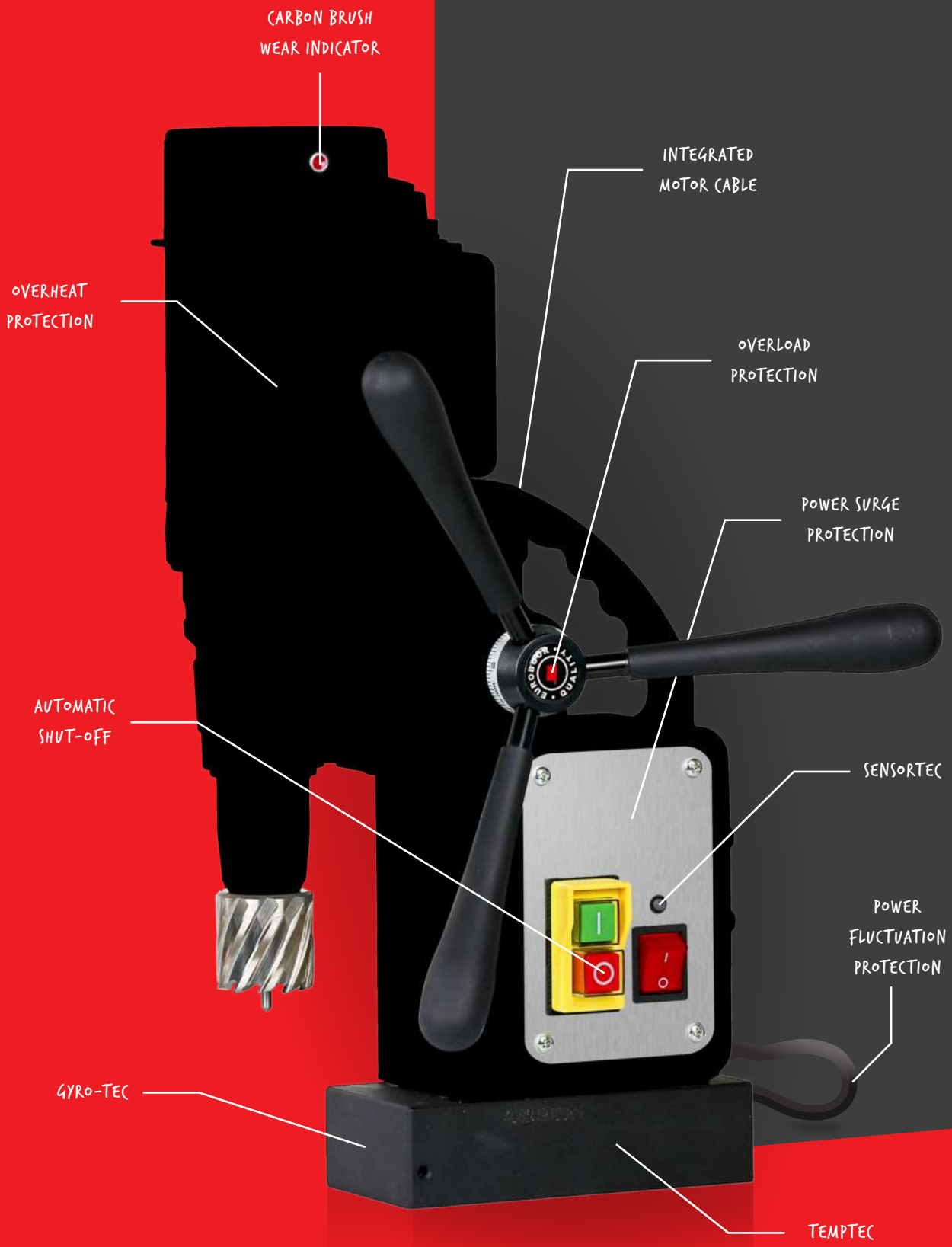



# ECO.30S+



Watch our machines in action on:  
[www.youtube.com/euroboorby](http://www.youtube.com/euroboorby)



## Technical data

Annular cutting	Ø 12 - 30 mm
Twist drilling (Weldon)	Ø 1 - 13 mm
Countersinking (Weldon)	Ø 10 - 35 mm
Length	275 mm
Width	190 mm
Height	293 - 383 mm
Stroke	90 mm
Weight*	8.5 kg
Magnet (l x w x h)	160 x 80 x 37 mm
Magnetic force	1,200 kg
Motor power	900 W
Total power	950 W
Speed (no load)	I 775 rpm
Speed (load 900 W)	I 400 rpm
Spindle (Weldon)	19.05 mm (3/4")
Voltage	110 - 120 V / 60 Hz
	220 - 240 V / 50 - 60 Hz

\*Exclusive power cord and handles

CARBON BRUSH  
WEAR INDICATOR



AUTOMATIC  
SHUT-OFF

POWER SURGE  
PROTECTION

POWER  
FLUCTUATION  
PROTECTION

GYRO-TEC

TEMPTEC

## Benefits

- Lightest Ø 30 mm magnetic drilling machine:
  - Most compact in class
  - Incredibly easy to handle
- Direct spindle drive and integrated tool cooling and lubrication
- Integrated slide for:
  - High accuracy
  - Enlarged lifecycle
  - Minimal vibration
- High-precision height adjustment for:
  - Low maintenance
  - Minimal wear correction
- Strong dual coil CNC machined 2-way magnet, causing the machine to use less energy, generate less heat and therefore lasts longer
- Reversible handles: to enable you to change the operation side of the feed handles in confined spaces
- Reduced risk of damaging machine, tools and workpiece and hurting operator
- Suitable for use in areas and workplaces where power supply is of less quality
- Reduced risk of armature damage
- Reduced risk of control unit(s) damage
- Timely service notification to avoid additional cost by unexpected downtime or unnecessary part replacement

## Features



Power surge  
protection



Power  
fluctuation  
protection



Gyro-Tec



Automatic  
shut-off



Oil lubricated  
gearbox



Carbon  
brush wear  
indicator



2-way  
magnet  
(TempTec)



8.5  
weight

Optimised motor efficiency and lifetime of key components due to oil lubricated gearbox



# ECO.32



Watch our machines in action on:  
[www.youtube.com/euroboorby](http://www.youtube.com/euroboorby)



## Technical data

Annular cutting	Ø 12 - 32 mm
Twist drilling	Ø 1 - 13 mm
Countersinking	Ø 10 - 40 mm
Length	320 mm
Width	210 mm
Height	370 - 512 mm
Stroke	150 mm
Weight*	11 kg
Magnet (l x w x h)	160 x 80 x 42 mm
Magnetic force	1,500 kg
Motor power	1,000 W
Total power	1,050 W
Speed (no load)	I 775 rpm
Speed (load 1,000 W)	I 440 rpm
Spindle (Weldon)	19.05 mm (3/4")
Voltage	110 - 120 V / 60 Hz
	220 - 240 V / 50 - 60 Hz

\*Exclusive power cord and handles



## Benefits

- One-speed gearbox
- Detachable spindle drive and integrated tool cooling and lubrication
- Integrated slide for:
  - High accuracy
  - Enlarged lifecycle
  - Minimal vibration
- High-precision height adjustment for:
  - Low maintenance
  - Minimal wear correction
- Strong dual coil CNC machined 2-way magnet, causing the machine to use less energy, generate less heat and therefore lasts longer

## Features



Magnet  
LED-indicator  
(SensorTec)



2-way  
magnet  
(TempTec)

# ECO.32-T



Watch our machines in action on:  
[www.youtube.com/euroboorby](http://www.youtube.com/euroboorby)



## Technical data

Annular cutting	Ø 12 - 32 mm
Twist drilling	Ø 1 - 13 mm
Countersinking	Ø 10 - 40 mm
Tapping	M3 - M12
Length	320 mm
Width	210 mm
Height	370 - 512 mm
Stroke	150 mm
Weight*	11 kg
Magnet (l x w x h)	160 x 80 x 42 mm
Magnetic force	1,500 kg
Motor power	1,000 W
Total power	1,050 W
Speed (no load)	I 150 - 600 rpm
Speed (load 1,000 W)	I 225 rpm
Spindle (Weldon)	19.05 mm (3/4")
Voltage	110 - 120 V / 60 Hz
	220 - 240 V / 50 - 60 Hz

\*Exclusive power cord and handles



## Benefits

- One-speed gearbox
- Detachable spindle drive and integrated tool cooling and lubrication
- Integrated slide for:
  - High accuracy
  - Enlarged lifecycle
  - Minimal vibration
- High-precision height adjustment for:
  - Low maintenance
  - Minimal wear correction
- Strong dual coil CNC machined 2-way magnet, causing the machine to use less energy, generate less heat and therefore lasts longer

## Features



Adjustable speed



R/L rotation



Magnet LED-indicator (SensorTec)



2-way magnet (TempTec)



Tapping

# ECO.40/2+



Watch our machines in action on:  
[www.youtube.com/euroboorby](http://www.youtube.com/euroboorby)



## Technical data

Annular cutting	Ø 12 - 40 mm
Twist drilling	Ø 1 - 13 mm
Countersinking	Ø 10 - 45 mm
Length	320 mm
Width	210 mm
Height	395 - 540 mm
Stroke	150 mm
Weight*	11.5 kg
Magnet (l x w x h)	160 x 80 x 42 mm
Magnetic force	1,500 kg
Motor power	1,050 W
Total power	1,100 W
Speed (no load)	I 720 rpm
	II 1,300 rpm
Speed (load 1,050 W)	I 315 rpm
	II 560 rpm
Spindle (Weldon)	19.05 mm (3/4")
Voltage	110 - 120 V / 60 Hz
	220 - 240 V / 50 - 60 Hz

\*Exclusive power cord and handles

## Benefits

- Particularly suitable for both annular cutting and twist drilling
- Detachable spindle drive and integrated tool cooling and lubrication
- Two-speed gearbox
- Integrated slide for:
  - High accuracy
  - Enlarged lifecycle
  - Minimal vibration
- High-precision height adjustment for:
  - Low maintenance
  - Minimal wear correction
- Strong dual coil CNC machined 2-way magnet causing the machine to use less energy, generate less heat and therefore lasts longer
- Reduced risk of damaging machine, tools and workpiece and hurting operator
- Suitable for use in areas and workplaces where power supply is of less quality
- Reduced risk of armature damage
- Reduced risk of control unit(s) damage
- Timely service notification to avoid additional cost by unexpected downtime or unnecessary part replacement



Shown extras not included.

## Features



Power surge protection



Power fluctuation protection



Gyro-Tec



Automatic shut-off



Carbon brush wear indicator



Magnet LED-indicator (SensorTec)



2-way magnet (TempTec)

# ECO.40S+



Watch our machines in action on:  
[www.youtube.com/euroboorby](http://www.youtube.com/euroboorby)



## Technical data

Annular cutting	Ø 12 - 40 mm
Twist drilling	Ø 1 - 16 mm
Countersinking	Ø 10 - 45 mm
Length	264 mm
Width	180 mm
Height	360 - 440 mm
Stroke	145 mm
Weight*	10.5 kg
Magnet (l x w x h)	160 x 80 x 42 mm
Magnetic force	1,500 kg
Motor power	1,150 W
Total power	1,200 W
Speed (no load)	I 600 rpm
Speed (load 1,150 W)	I 380 rpm
Spindle (Weldon)	19.05 mm (3/4")
Voltage	110 - 120 V / 60 Hz
	220 - 240 V / 50 - 60 Hz

\*Exclusive power cord and handles

## Benefits

- Lightest Ø 40 mm magnetic drilling machine
- Fits cutters up to 110 mm DoC
- High-efficiency motor with less heat generation
- High-accuracy capstan hub
- Direct spindle drive and integrated tool cooling and lubrication
- Integrated slide for:
  - High accuracy
  - Enlarged lifecycle
  - Minimal vibration
- High-precision height adjustment for:
  - Low maintenance
  - Minimal wear correction
- Strong dual coil CNC machined 2-way magnet, causing the machine to use less energy, generate less heat and therefore lasts longer
- Reduced risk of damaging machine, tools and workpiece and hurting operator
- Suitable for use in areas and workplaces where power supply is of less quality
- Reduced risk of armature damage
- Reduced risk of control unit(s) damage
- Timely service notification to avoid additional cost by unexpected downtime or unnecessary part replacement
- Reversible handles: to enable you to change the operation side of the feed handles in confined spaces

## Features



Power surge protection



Power fluctuation protection



Gyro-Tec



Integrated motor cable



Automatic shut-off



Oil lubricated gearbox



Carbon brush wear indicator



2-way magnet (TempTec)



Magnet LED-indicator (SensorTec)

Optimised motor efficiency and lifetime of key components due to oil lubricated gearbox



**SAFETY FIRST**



# ECO.40S+/P



Watch our machines in action on:  
[www.youtube.com/euroboorby](http://www.youtube.com/euroboorby)



## Technical data

Annular cutting	Ø 12 - 40 mm
Twist drilling	Ø 1 - 16 mm
Countersinking	Ø 10 - 45 mm
Length	264 mm
Width	180 mm
Height	360 - 440 mm
Stroke	145 mm
Weight*	10.5 kg
Magnet (l x w x h)	160 x 80 x 42 mm
Magnetic force	1,500 kg
Motor power	1,150 W
Total power	1,200 W
Speed (no load)	I 600 rpm
Speed (load 1,150 W)	I 380 rpm
Spindle (Weldon)	19.05 mm (3/4")
Voltage	110 - 120 V / 60 Hz
	220 - 240 V / 50 - 60 Hz

\*Exclusive power cord and handles



## Benefits

- Safest Ø 40 mm magnetic drilling machine
- Fits cutters up to 110 mm DoC
- High-efficiency motor with less heat generation
- High-accuracy capstan hub
- Direct spindle drive and integrated tool cooling and lubrication
- Integrated slide for:
  - High accuracy
  - Enlarged lifecycle
  - Minimal vibration
- High-precision height adjustment for:
  - Low maintenance
  - Minimal wear correction
- Reduced risk of damaging machine, tools and workpiece and hurting operator
- Suitable for use in areas and workplaces where power supply is of less quality
- Reduced risk of armature damage
- Reduced risk of control unit(s) damage
- Timely service notification to avoid additional cost by unexpected downtime or unnecessary part replacement
- Reversible handles: to enable you to change the operation side of the feed handles in confined spaces

## Magnet benefits

- Permanent, non-electric monobloc magnet system
- No loss of magnetic grip in case of electric power cuts or fluctuations
- Powerful hold, even on thinner steel

## Features



Power surge protection



Power fluctuation protection



Gyro-Tec



Integrated motor cable



Automatic shut-off



Oil lubricated gearbox



Carbon brush wear indicator



Permanent magnet



Magnet LED-indicator (SensorTec)

Optimised motor efficiency and lifetime of key components due to oil lubricated gearbox



# ECO.50+ / T



Watch our machines in action on:  
[www.youtube.com/euroboorby](http://www.youtube.com/euroboorby)



## Technical data

Annular cutting	Ø 12 - 50 mm
Twist drilling	Ø 1 - 23 mm
Countersinking	Ø 10 - 55 mm
Tapping	M3 - M20
Length	320 mm
Width	210 mm
Height	385 - 540 mm
Stroke	170 mm
Weight*	13.5 kg
Magnet (l x w x h)	170 x 85 x 48 mm
Magnetic force	1,850 kg
Motor power	1,250 W
Total power	1,375 W
Speed (no load)	I 100 - 280 rpm
	II 185 - 530 rpm
Speed (load 1,250 W)	I 250 rpm
	II 460 rpm
Spindle (Weldon)	MT2 19.05 mm (3/4")
Voltage	110 - 120 V / 60 Hz
	220 - 240 V / 50 - 60 Hz

\*Exclusive power cord and handles



## Benefits

- Morse Taper 2 spindle with integrated tool cooling and lubrication
- Two-speed gearbox
- Integrated slide for:
  - High accuracy
  - Enlarged lifecycle
  - Minimal vibration
- High-precision height adjustment for:
  - Low maintenance
  - Minimal wear correction
- Strong dual coil CNC machined 2-way magnet causing the machine to use less energy, generate less heat and therefore lasts longer
- Reduced risk of damaging machine, tools and workpiece and hurting operator
- Suitable for use in areas and workplaces where power supply is of less quality
- Reduced risk of armature damage
- Reduced risk of control unit(s) damage
- Timely service notification to avoid additional cost by unexpected downtime or unnecessary part replacement

## Features



Adjustable speed



R/L rotation



Overload protection



Overheat protection



Power surge protection



Power fluctuation protection



Gyro-Tec



Automatic shut-off



Smart Restart



Carbon brush wear indicator



Magnet LED-indicator (SensorTec)



2-way magnet (TempTec)



Tapping

# ECO.50S+



Watch our machines in action on:  
[www.youtube.com/euroboorby](http://www.youtube.com/euroboorby)



## Technical data

Annular cutting	Ø 12 - 50 mm
Twist drilling	Ø 1 - 23 mm
Countersinking	Ø 10 - 55 mm
Length	320 mm
Width	200 mm
Height	445 - 615 mm
Stroke	170 mm
Weight*	12 kg
Magnet (l x w x h)	168 x 84 x 42 mm
Magnetic force	1,700 kg
Motor power	1,250 W
Total power	1,300 W
Speed (no load)	I 380 rpm
	II 690 rpm
Speed (load 1,250 W)	I 235 rpm
	II 415 rpm
Spindle (Weldon)	MT3 19.05 mm (3/4")
Voltage	110 - 120 V / 60 Hz
	220 - 240 V / 50 - 60 Hz

\*Exclusive power cord and handles



## Benefits

- High-accuracy capstan hub
- Morse Taper 3 spindle with integrated tool cooling and lubrication
- Integrated slide for:
  - High accuracy
  - Enlarged lifecycle
  - Minimal vibration
- High-precision height adjustment for:
  - Low maintenance
  - Minimal wear correction
- Strong dual coil CNC machined 2-way magnet, causing the machine to use less energy, generate less heat and therefore lasts longer
- Reduced risk of damaging machine, tools and workpiece and hurting operator
- Suitable for use in areas and workplaces where power supply is of less quality
- Reduced risk of armature damage
- Reduced risk of control unit(s) damage
- Timely service notification to avoid additional cost by unexpected downtime or unnecessary part replacement

## Features

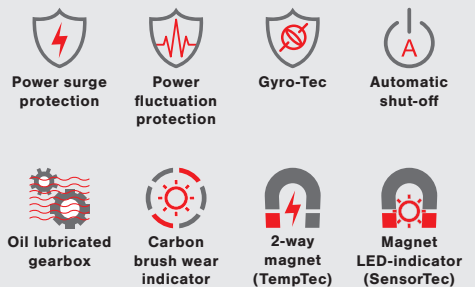

Optimised motor efficiency and lifetime of key components due to oil lubricated gearbox





# Drilling as efficiently as you possibly can!

Euroboor's magnetic drilling machines that truly match your level of professionalism. There is no doubt your needs for fully assisted and fastest drilling with the highest accuracy are being met by our **ECO.55s+T** and **ECO.55s+TA**



## Top features

**LED load indicators and digital display with Smart Restart technology**

**Easily accessible carbon brushes**  
When replacement is needed the motor will be shut-off automatically

**Oil lubricated gearbox**  
Maximum lubrication

**Integrated slide and gearbox system**  
- High accuracy  
- Sturdy design enlarges lifecycle  
- Minimal vibration

**Automatic drill functionality with automatic return on the ECO.55S+/TA**  
(Only for annular cutting)

**Z-profile guide rails**  
Maximum contact surface

**Clear and easy controls**  
With RPM dial and right/left rotation functionality



### LED load indicators

- |   |   |
|---|---|
| ● ● ● ●                                   | ● ● ● ●                                   |
| 1. Machine is on.<br>No load.             | 2. Start drilling.<br>Ideal working load. |
| ● ● ● ●                                   | ● ● ● ●                                   |
| 3. When drilling.<br>Acceptable overload. | 4. Close to overload.<br>Reduce pressure. |

### \* Smart Restart

When the motor is in overload, the Smart Restart torque control technology (  ) ensures trouble-free continuation of your drilling job. When the feed pressure is reduced, the machine's electronics recognises the reduction and the motor continues. This benefits your drilling process, saves time and prevents excessive tool wear and failure.

 A flashing red light with beeping sound means the overload limit is exceeded. The motor halts.\*

# ECO.55S+/T



Watch our machines in action on:  
[www.youtube.com/euroboorby](http://www.youtube.com/euroboorby)



## Technical data

Annular cutting	Ø 12 - 55 mm
Twist drilling	Ø 1 - 23 mm
Countersinking	Ø 10 - 60 mm
Tapping	M3 - M20
Length	320 mm
Width	200 mm
Height	490 - 660 mm
Stroke	170 mm
Weight*	12.9 kg
Magnet (l x w x h)	168 x 84 x 49 mm
Magnetic force	1,850 kg
Motor power	1,600 W
Total power	1,700 W
Speed (no load)	I 60 - 275 rpm
	II 100 - 500 rpm
Speed (load 1,600 W)	I 60 - 275 rpm
	II 100 - 500 rpm
Spindle (Weldon)	MT3 19.05 mm (3/4")
Voltage	110 - 120 V / 60 Hz
	220 - 240 V / 50 - 60 Hz

\*Exclusive power cord and handles



## Benefits

- Easily accessible carbon brushes. Motor will automatically shut-off in case of replacement
- High-accuracy capstan hub
- Morse Taper 3 spindle with integrated tool cooling and lubrication
- Integrated slide for:
  - High accuracy
  - Enlarged lifecycle
  - Minimal vibration
- High-precision height adjustment for:
  - Low maintenance
  - Minimal wear correction
- Strong dual coil CNC machined 2-way magnet causing the machine to use less energy, generate less heat and therefore lasts longer
- Reduced risk of damaging machine, tools and workpiece and hurting operator
- Suitable for use in areas and workplaces where power supply is of less quality
- Reduced risk of armature damage
- Reduced risk of control unit(s) damage
- Timely service notification to avoid additional cost by unexpected downtime or unnecessary part replacement
- Also available with permanent TUBE magnet for both pipe and flat material (page. 41)

## Features

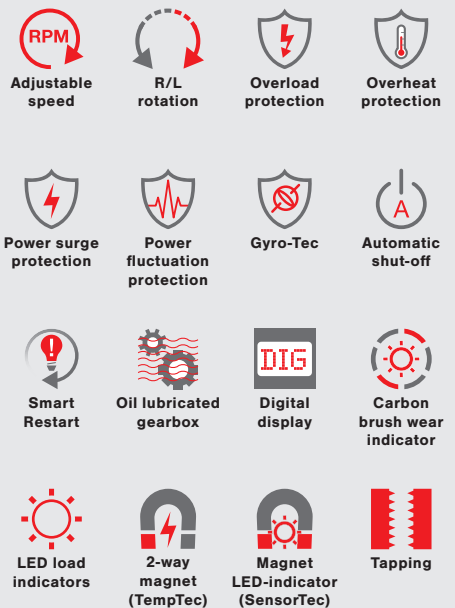

Optimised motor efficiency and lifetime of key components due to oil lubricated gearbox



# ECO.55S+/TA



Watch our machines in action on:  
[www.youtube.com/euroboorby](http://www.youtube.com/euroboorby)



## Technical data

Annular cutting	Ø 12 - 55 mm
Twist drilling	Ø 1 - 23 mm
Countersinking	Ø 10 - 60 mm
Tapping	M3 - M20
Length	345 mm
Width	305 mm
Height	490 - 660 mm
Stroke	170 mm
Weight*	15.8 kg
Magnet (l x w x h)	168 x 84 x 49 mm
Magnetic force	1,850 kg
Motor power	1,600 W
Total power	1,700 W
Speed (no load)	I 60 - 275 rpm
	II 100 - 500 rpm
Speed (load 1,600 W)	I 60 - 275 rpm
	II 100 - 500 rpm
Spindle (Weldon)	MT3 19.05 mm (3/4")
Voltage	110 - 120 V / 60 Hz
	220 - 240 V / 50 - 60 Hz

\*Exclusive power cord and handles

CARBON BRUSH  
WEAR INDICATOR

OVERHEAT  
PROTECTION



## Benefits

- Easily accessible carbon brushes. Motor will automatically shut-off in case of replacement
- High-accuracy capstan hub
- Morse Taper 3 spindle with integrated tool cooling and lubrication
- Integrated slide for:
  - High accuracy
  - Enlarged lifecycle
  - Minimal vibration
- High-precision height adjustment for:
  - Low maintenance
  - Minimal wear correction
- Strong dual coil CNC machined 2-way magnet causing the machine to use less energy, generate less heat and therefore lasts longer
- Reduced risk of damaging machine, tools and workpiece and hurting operator
- Suitable for use in areas and workplaces where power supply is of less quality
- Reduced risk of armature damage
- Reduced risk of control unit(s) damage
- Timely service notification to avoid additional cost by unexpected downtime or unnecessary part replacement

## Features



Adjustable speed



R/L rotation



Overload protection



Overheat protection



Power surge protection



Power fluctuation protection



Gyro-Tec



Automatic shut-off



Smart Restart



Oil lubricated gearbox



Digital display



Carbon brush wear indicator



LED load indicators



2-way magnet (TempTec)



Magnet LED-indicator (SensorTec)



Auto feed and return for cutters



Tapping

Optimised motor efficiency and lifetime of key components due to oil lubricated gearbox



**SAFETY FIRST**



# ECO.60S+



Watch our machines in action on:  
[www.youtube.com/euroboorby](http://www.youtube.com/euroboorby)



## Technical data

Annular cutting	Ø 12 - 60 mm
Twist drilling	Ø 1 - 23 mm
Countersinking	Ø 10 - 65 mm
Length	320 mm
Width	200 mm
Height	452 - 622 mm
Stroke	170 mm
Weight*	12.9 kg
Magnet (l x w x h)	168 x 84 x 49 mm
Magnetic force	1,850 kg
Motor power	1,600 W
Total power	1,700 W
Speed (no load)	I 60 - 275 rpm
	II 100 - 500 rpm
Speed (load 1,600 W)	I 60 - 275 rpm
	II 100 - 500 rpm
Spindle (Weldon)	MT3 19.05 mm (3/4")
Voltage	110 - 120 V / 60 Hz
	220 - 240 V / 50 - 60 Hz

\*Exclusive power cord and handles



## Benefits

- High-accuracy capstan hub
- Morse Taper 3 spindle with integrated tool cooling and lubrication
- Integrated slide for:
  - High accuracy
  - Enlarged lifecycle
  - Minimal vibration
- High-precision height adjustment for:
  - Low maintenance
  - Minimal wear correction
- Strong dual coil CNC machined 2-way magnet causing the machine to use less energy, generate less heat and therefore lasts longer
- Reduced risk of damaging machine, tools and workpiece and hurting operator
- Suitable for use in areas and workplaces where power supply is of less quality
- Reduced risk of armature damage
- Reduced risk of control unit(s) damage
- Timely service notification to avoid additional cost by unexpected downtime or unnecessary part replacement

## Features



Adjustable speed



Overload protection



Overheat protection



Power surge protection



Power fluctuation protection



Gyro-Tec



Automatic shut-off



Smart Restart



Oil lubricated gearbox



Carbon brush wear indicator



2-way magnet (TempTec)



Magnet LED-indicator (SensorTec)

Optimised motor efficiency and lifetime of key components due to oil lubricated gearbox



# ECO.80S+



Watch our machines in action on:  
[www.youtube.com/euroboorby](http://www.youtube.com/euroboorby)



## Technical data

Annular cutting	Ø 12 - 80 mm
Twist drilling	Ø 1 - 31.75 mm
Countersinking	Ø 10 - 85 mm
Length	365 mm
Width	310 mm
Height	510 - 710 mm
Stroke	260 mm
Weight*	27.3 kg
Magnet (l x w x h)	220 x 110 x 64 mm
Magnetic force	3,000 kg
Motor power	1,700 W
Total power	1,800 W
Speed (no load)	I 200 rpm
	II 300 rpm
	III 415 rpm
	IV 650 rpm
Speed (load 1,700 W)	I 150 rpm
	II 200 rpm
	III 275 rpm
	IV 400 rpm
Spindle (Weldon)	MT3 31.75 mm (1 1/4")
Voltage	110 - 120 V / 60 Hz
	220 - 240 V / 50 - 60 Hz

\*Exclusive power cord and handles

## Benefits

- Morse Taper 3 spindle with integrated tool cooling and lubrication
- Strong dual coil CNC machined 2-way magnet, causing the machine to use less energy, generate less heat and therefore lasts longer
- Reduced risk of damaging machine, tools and workpiece and hurting operator
- Suitable for use in areas and workplaces where power supply is of less quality
- Reduced risk of armature damage
- Reduced risk of control unit(s) damage
- Timely service notification to avoid additional cost by unexpected downtime or unnecessary part replacement



## Features



Overload protection



Overheat protection



Power surge protection



Power fluctuation protection



Gyro-Tec



Automatic shut-off



Smart Restart



Oil lubricated gearbox



Carbon brush wear indicator



2-way magnet (TempTec)



Magnet LED-indicator (SensorTec)

Optimised motor efficiency and lifetime of key components due to oil lubricated gearbox



# ECO.100S+/TD



Watch our machines in action on:  
[www.youtube.com/euroboorby](http://www.youtube.com/euroboorby)



## Technical data

Annular cutting	Ø 12 - 100 mm
Twist drilling	Ø 1 - 31.75 mm
Countersinking	Ø 10 - 105 mm
Tapping	M3 - M30
Length	365 mm
Width	310 mm
Height	515 - 715 mm
Stroke	260 mm
Weight*	31 kg
Magnet (l x w x h)	220 x 110 x 64 mm
Magnetic force	3,000 kg
Motor power	1,900 W
Total power	2,050 W
Speed (no load)	I 42 - 110 rpm
	II 65 - 190 rpm
	III 140 - 400 rpm
	IV 220 - 620 rpm
Speed (load 1,900 W)	I 85 rpm
	II 152 rpm
	III 270 rpm
	IV 480 rpm
Spindle (Weldon)	MT3 31.75 mm (1 1/4")
Voltage	110 - 120 V / 60 Hz
	220 - 240 V / 50 - 60 Hz

\*Exclusive power cord and handles

## Benefits

- Precise positioning swivel base, rotate the machine 30° both ways and slide 15-20 mm forward and backwards
- Morse Taper 3 spindle with integrated tool cooling and lubrication
- Strong dual coil CNC machined 2-way magnet, causing the machine to use less energy, generate less heat and therefore lasts longer
- Reduced risk of damaging machine, tools and workpiece and hurting operator
- Suitable for use in areas and workplaces where power supply is of less quality
- Reduced risk of armature damage
- Reduced risk of control unit(s) damage
- Timely service notification to avoid additional cost by unexpected downtime or unnecessary part replacement

## Features



Adjustable speed



Torque control



R/L rotation



Overload protection



Overheat protection



Power surge protection



Power fluctuation protection



Gyro-Tec



Automatic shut-off



Smart Restart



Oil lubricated gearbox



Carbon brush wear indicator



2-way magnet (TempTec)



Magnet LED-indicator (SensorTec)



Swivelbase magnet



Tapping



Optimised motor efficiency and lifetime of key components due to oil lubricated gearbox



# ECO.100S+/CT



Watch our machines in action on:  
[www.youtube.com/euroboorby](http://www.youtube.com/euroboorby)



## Technical data

Annular cutting	Ø 12 - 100 mm
Twist drilling	Ø 1 - 31.75 mm
Countersinking	Ø 10 - 105 mm
Tapping	M3 - M30
Milling	Ø 14 mm
Length	497 mm
Width	375 mm
Height	615 - 793 mm
Stroke	260 mm
Travel distance	X-axis 110 mm
	Y-axis 120 mm
Weight*	55 kg
Magnet (l x w x h)	220 x 220 x 64 mm
Magnetic force	4,300 kg
Motor power	1,900 W
Total power	2,200 W
Speed (no load)	I 42 - 110 rpm
	II 65 - 190 rpm
	III 140 - 400 rpm
	IV 220 - 620 rpm
Speed (load 1,900 W)	I 42 rpm
	II 65 rpm
	III 140 rpm
	IV 220 rpm
Spindle (Weldon)	MT3 31.75 mm (1 1/4")
Voltage	110 - 120 V / 60 Hz
	220 - 240 V / 50 - 60 Hz

\*Exclusive power cord and handles



## Benefits

- Cross Table base to give dynamic positioning during drilling procedure over a range of 110 mm (x-axis) and 120 mm (y-axis)
- Milling feature to create slots and work on complex workpieces
- Switch to Tapping to create perfectly centered threads, while machine stays fixed on workpiece
- Strong dual coil CNC machined 2-way magnet, causing the machine to use less energy, generate less heat and therefore lasts longer
- Advanced safety features to reduce the risks of damaging the machine, tools, workpiece, armature, control unit(s) or hurting the operator
- Morse Taper 3 spindle with integrated tool cooling and lubrication
- Suitable for use in areas and workplaces where power supply is of less quality
- Timely service notification to avoid additional costs of unexpected downtime or unnecessary part replacement

## Features



Optimised motor efficiency and lifetime of key components due to oil lubricated gearbox



# ECO.200S/T



Watch our machines in action on:  
[www.youtube.com/euroboorbv](http://www.youtube.com/euroboorbv)



## Technical data

Annular cutting	Ø 12 - 200 mm
Twist drilling	Ø 1 - 50 mm
Countersinking	Ø 10 - 205 mm
Tapping	M3 - M48
Length	515 mm
Width	265 mm
Height	650 - 905 mm
Stroke	255 mm
Weight*	58.5 kg
Magnet (l x w x h)	350 x 125 x 66 mm
Magnetic force	3,680 kg
Motor power	2,600 W
Total power	2,750 W
Speed (no load)	I 40 - 80 rpm
	II 60 - 125 rpm
	III 145 - 300 rpm
	IV 230 - 470 rpm
Speed (load 2600 W)	I 29 - 75 rpm
	II 46 - 120 rpm
	III 110 - 285 rpm
	IV 174 - 452 rpm
Spindle (Weldon)	MT4 31.75 mm (1 1/4")
Voltage	220 - 240 V / 50 - 60 Hz

\*Exclusive power cord and handles



## Benefits

- Four-speed gearbox
- Integrated tool cooling and lubrication tank and fluid level indication
- Integrated safety strap and lifting shackle
- Progressive feed assist
- Morse Taper 4 spindle
- Strong triple coil CNC machined magnet
- Brushless technology

## Features



Adjustable speed



R/L rotation



Overload protection



Overheat protection



Power surge protection



Power fluctuation protection



Gyro-Tec



Integrated motor cable



Brushless motor



Oil lubricated gearbox



2-way magnet (TempTec)



Magnet LED-indicator (SensorTec)



Tapping

Optimised motor efficiency and lifetime of key components due to oil lubricated gearbox



# F16+



Watch our machines in action on:  
[www.youtube.com/euroborby](http://www.youtube.com/euroborby)



## Technical data

Twist drilling	Ø 1 - 16 mm*
Length	310 mm
Width	170 mm
Height	325 - 495 mm
Stroke	170 mm
Weight**	7.5 kg
Magnet (l x w x h)	160 x 80 x 36 mm
Magnetic force	1,200 kg
Voltage	110 - 120 V / 60 Hz
	220 - 240 V / 50 - 60 Hz

\*Hand drill dependable

\*\*Exclusive power cord and handles

## Benefits

- Perfect solution for high-precision small diameter drilling tasks
- 43 mm Euro collar connection (33 mm and 38 mm filler rings included)
- Safe and easy rear mounted socket
- High-accuracy capstan hub
- High-precision height adjustment for:
  - Low maintenance
  - Minimal wear correction
- Strong dual coil CNC machined 2-way magnet causing the machine to use less energy, generate less heat and therefore lasts longer
- Reversible handles: to enable you to change the operation side of the feed handles in confined spaces
- Reduced risk of damaging machine, tools and workpiece and hurting operator
- Suitable for use in areas and workplaces where power supply is of less quality
- Reduced risk of armature damage
- Reduced risk of control unit(s) damage
- No unexpected downtime or unnecessary part replacement



Mounted hand drilling machine not included.

## Features



Power surge protection



Power fluctuation protection



Gyro-Tec



2-way magnet (TempTec)



Magnet LED-indicator (SensorTec)

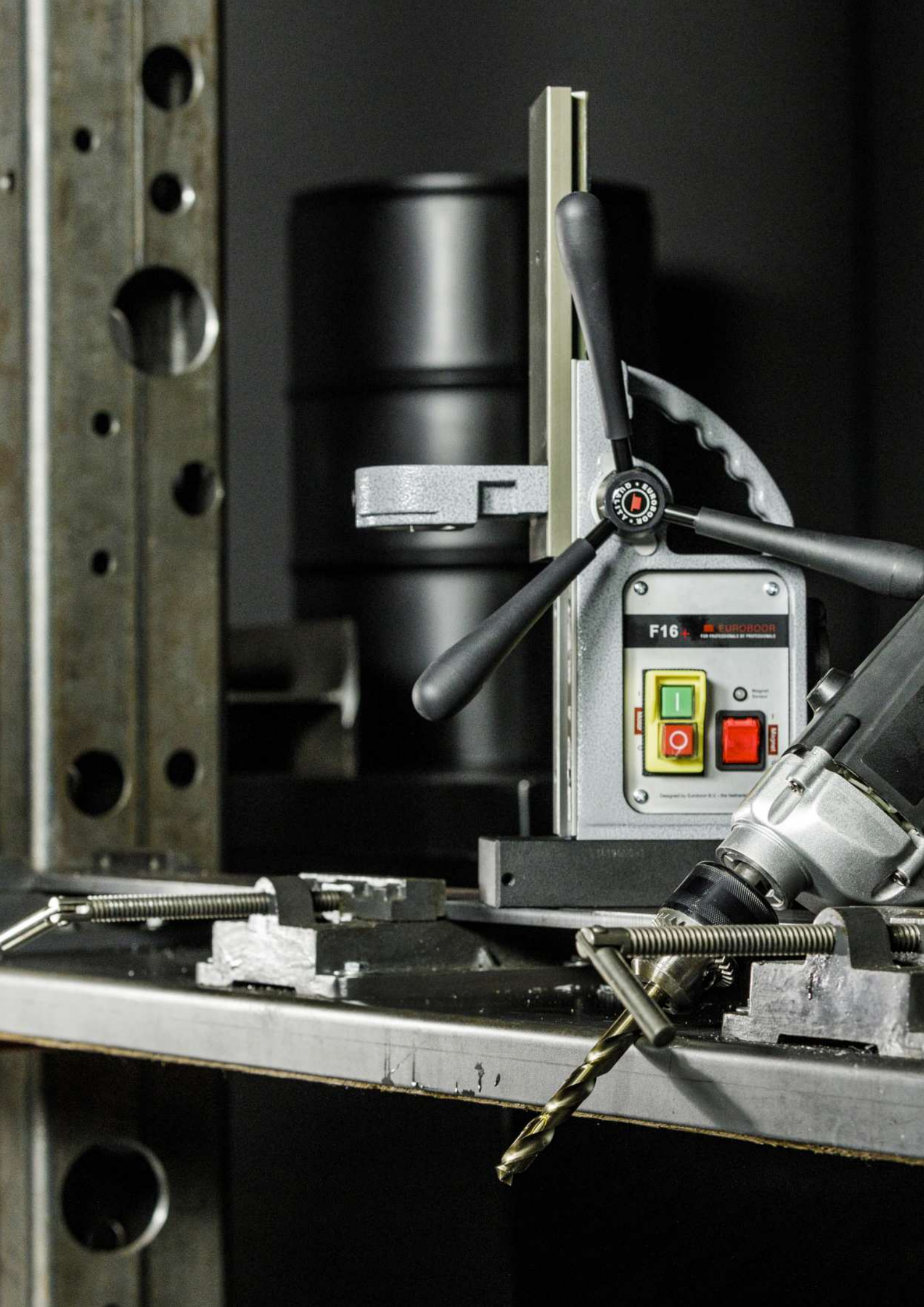



# Unique design, unique usage

Drilling high-precision holes in steel tubes and pipes has always been a hassle. Until now! "Position and use" is what you expect of a portable power tool. Forget about the time consuming process of clamping all kinds of pipe adapters to your work piece.

Meet our TUBE-serie, an innovative generation drilling machines specifically designed for drilling on curved material. By joining forces with Magswitch, technology leader in switchable magnetic technology, we have been able to develop a concept that instantly addresses, and

drastically improves work efficiency in the pipe industry. Not only will these help you save time. Its strong, powerful and sturdy design will also actively enable you to drill holes as fast as possible.

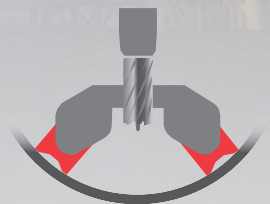
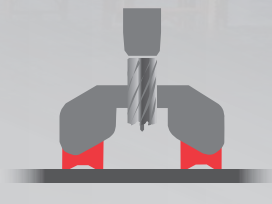

**The magnets can be adjusted for the best position on round and flat surfaces. No extra accessories needed**

**Safe**

Magnets do not require electrical power.

**Light**

The machines are extremely light.  
 TUBE.30 - 10.3 kg  
 TUBE.30s+ - 11 kg  
 TUBE.55S/T - 17.6 kg  
 TUBE.55s+/T - 17.6 kg  
 TUBE.55/AIR - 16.7 kg

**Strong**

Maintains strong grip on thin steel. Minimal thickness of 3 mm.

**Easy to use**

Automatically conform to any pipe Ø 76.2 mm or larger in diameter.

**Efficient**

One tool for flat or round surfaces without the need for expensive adapters – save time and money.

# TUBE.30



Watch our machines in action on:  
[www.youtube.com/euroboorby](http://www.youtube.com/euroboorby)



## Technical data

Annular cutting	Ø 12 - 30 mm
Twist drilling (Weldon)	Ø 1 - 13 mm
Countersinking (Weldon)	Ø 10 - 35 mm
Length	275 mm
Width	185 mm
Height	326 - 416 mm
Stroke	90 mm
Weight*	10.3 kg
Magnet (l x w x h)	187 x 165 x 83 mm
Magnetic force	532 kg
Min. material thickness	3 mm
Min. pipe diameter	76.2 mm (3")
Motor power	900 W
Total power	950 W
Speed (no load)	I 775 rpm
Speed (load 900 W)	I 400 rpm
Spindle (Weldon)	19.05 mm (3/4")
Voltage	110 - 120 V / 60 Hz
	220 - 240 V / 50 - 60 Hz

\*Exclusive power cord and handles

## Benefits

- The magnets can be adjusted for the best position on round and flat surfaces
- High-accuracy capstan hub
- Direct spindle drive and integrated tool cooling and lubrication
- One-speed gearbox
- Integrated slide for:
  - High accuracy
  - Enlarged lifecycle
  - Minimal vibration
- High-precision height adjustment for:
  - Low maintenance
  - Minimal wear correction
- Reversible handles: to enable you to change the operation side of the feed handles in confined spaces



## Features



Permanent magnet)

# TUBE.55S+/T



Watch our machines in action on:  
[www.youtube.com/euroboorby](http://www.youtube.com/euroboorby)



## Technical data

Annular cutting	Ø 12 - 55 mm
Twist drilling	Ø 1 - 23 mm
Countersinking	Ø 10 - 60 mm
Tapping	M3 - M20
Length	320 mm
Width	210 mm
Height	523 - 693 mm
Stroke	170 mm
Weight*	16 kg
Magnet (l x w x h)	275 x 190 x 90 mm
Magnetic force	900 kg
Min. material thickness	3 mm
Min. pipe diameter	80 mm
Motor power	1,600 W
Total power	1,700 W
Speed (no load)	I 60 - 275 rpm
	II 100 - 500 rpm
Speed (load 1,600 W)	I 60 - 275 rpm
	II 100 - 500 rpm
Spindle (Weldon)	MT3 19.05 mm (3/4")
Voltage	110 - 120 V / 60 Hz
	220 - 240 V / 50 - 60 Hz

\*Exclusive power cord and handles

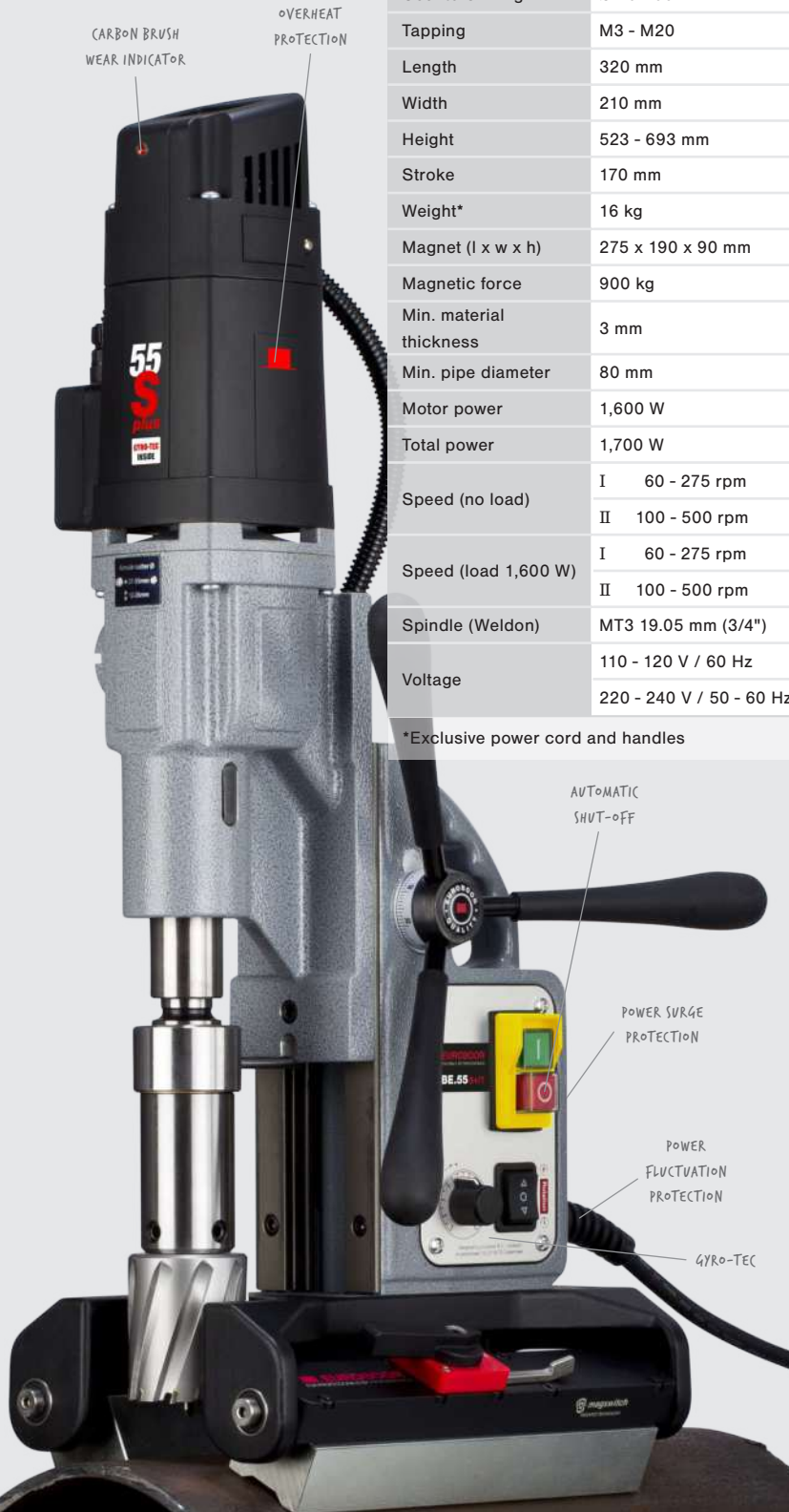

## Benefits

- The magnets can be adjusted for the best position on round and flat surfaces
- Easily accessible carbon brushes. Motor will automatically shut-off in case of replacement
- High-accuracy capstan hub
- Morse Taper 3 spindle with integrated tool cooling and lubrication
- Integrated slide for:
  - High accuracy
  - Enlarged lifecycle
  - Minimal vibration
- High-precision height adjustment for:
  - Low maintenance
  - Minimal wear correction
- Reduced risk of damaging machine, tools and workpiece and hurting operator
- Suitable for use in areas and workplaces where power supply is of less quality
- Reduced risk of armature damage
- Reduced risk of control unit(s) damage
- Timely service notification to avoid additional cost by unexpected downtime or unnecessary part replacement
- Also available with electromagnetic magnet (page. 28)

## Features



Adjustable speed



R/L rotation



Overload protection



Overheat protection



Power surge protection



Power fluctuation protection



Gyro-Tec



Automatic shut-off



Oil lubricated gearbox



Digital display



Carbon brush wear indicator



LED load indicators



Permanent magnet



Tapping

Optimised motor efficiency and lifetime of key components due to oil lubricated gearbox



# TUBE.55/AIR



Watch our machines in action on:  
[www.youtube.com/euroboorby](http://www.youtube.com/euroboorby)



## Technical data

Annular cutting	Ø 12 - 52 mm (HSS) Ø 12 - 55 mm (TCT)
Twist drilling	Ø 1 - 23 mm
Countersinking	Ø 10 - 55 mm
Length	345 mm
Width	245 mm
Height	630 - 730 mm
Stroke	167 mm
Weight*	16.7 kg
Magnet (l x w x h)	275 x 190 x 90 mm
Magnetic force	900 kg
Min. material thickness	3 mm
Min. pipe diameter	80 mm
Speed (no load)	380 rpm
Spindle (Weldon)	MT3 19.05 mm (3/4")
Power source	Air, min. 6.3 bar, max. 8 bar, consumption 1.1 m <sup>3</sup> /min

\*Exclusive handles



## Benefits

- Air-powered motor system
- The magnets can be adjusted for the best position on round and flat surfaces
- Powerful, spark-free, explosion-safe motor
- Large 167 mm stroke
- Automatic, integrated lubrication and cooling system
- Anti-static construction
- Also available with permanent base magnet (page. 53)

## Magnet benefits

- Permanent, non-electric magnet system
- No loss of magnetic grip in case of electric power cuts or fluctuations
- Flexible dual magnet array which automatically adjust to the geometry of the workpiece
- Powerful hold, even on thinner steel thicknesses

## Features



Permanent magnet



Air motor:  
min 6.3 bar  
(90 PSI)



Atex

# AIR.55



Watch our machines in action on:  
[www.youtube.com/euroboorby](http://www.youtube.com/euroboorby)



## Technical data

Annular cutting	Ø 12 - 52 mm (HSS) Ø 12 - 55 mm (TCT)
Twist drilling	Ø 1 - 23 mm
Countersinking	Ø 10 - 55 mm
Length	380 mm
Width	245 mm
Height	615 - 705 mm
Stroke	167 mm
Weight*	16.5 kg
Magnet (l x w x h)	183 x 100 x 55 mm
Magnetic force	900 kg
Speed (no load)	380 rpm
Spindle (Weldon)	MT3 19.05 mm (3/4")
Power source	Air, min. 6.3 bar, max. 8 bar, consumption 1.1 m <sup>3</sup> /min

\*Exclusive handles



## Benefits

- Air-powered motor system
- Powerful, spark-free, explosion-safe motor
- Single operation knob for magnet and motor with 'deadman's' control
- Large 167 mm stroke
- Automatic, integrated lubrication and cooling system
- Anti-static construction
- Safety guard
- Also available with permanent tube magnet for both pipe and flat material (page. 48)

## Magnet benefits

- Permanent, non-electric monobloc magnet system
- No loss of magnetic grip in case of electric power cuts or fluctuations
- Powerful hold, even on thinner steel thicknesses

## Features



Permanent magnet



Air motor:  
min 6.3 bar  
(90 PSI)



Atex



**INNOVATION IS HERE**

**VAC.50S+**

**IT SUCKS!**

# VAC.50S+



Watch our machines in action on:  
[www.youtube.com/euroboorby](http://www.youtube.com/euroboorby)



## Technical data

<b>Annular cutting</b>	
- steel and hard metals	Ø 12 - 30 mm
- other metals and plastic	Ø 12 - 50 mm
<b>Twist drilling</b>	
- steel and hard metals	Ø 1 - 13 mm
- other metals and plastic	Ø 1 - 23 mm
Countersinking	Ø 10 - 55 mm
Length	430 mm
Width	190 mm
Height	420 - 590 mm
Stroke	170 mm
Weight*	9.9 kg
Vac-base (l x w x h)	300 x 140 x 21 mm
Adsorption force	300 kg
<b>Vacuum motor (integrated)</b>	
- Air flow	15 L/min
- Gauge pressure	-80 kPa
- Power	12 W
- Voltage	12 V
Motor power	1,250 W
Total power	1,300 W
Speed (no load)	I 380 rpm
	II 690 rpm
Speed (load 1,250 W)	I 235 rpm
	II 415 rpm
Spindle (Weldon)	MT3 19.05 mm (3/4")
Voltage	110 - 120 V / 60 Hz
	220 - 240 V / 50 - 60 Hz

\*Exclusive power cord and handles

## Benefits

- High-accuracy capstan hub
- Morse Taper 3 spindle with integrated tool cooling and lubrication
- Integrated slide for:
  - High accuracy
  - Enlarged lifecycle
  - Minimal vibration
- High-precision height adjustment for:
  - Low maintenance
  - Minimal wear correction
- Vacuum technology for almost all (magnetic and non-magnetic) smooth surfaces
- Reduced risk of damaging machine, tools and workpiece and hurting operator
- Suitable for use in areas and workplaces where power supply is of less quality
- Reduced risk of armature damage
- Reduced risk of control unit(s) damage
- Timely service notification to avoid additional cost by unexpected downtime or unnecessary part replacement

## Features



Overload protection



Overheat protection



Power surge protection



Power fluctuation protection



Vacu-Tec



Integrated motor cable



Automatic shut-off



Oil lubricated gearbox



Carbon brush wear indicator



VAC Vacuum LED-indicator



Optimised motor efficiency and lifetime of key components due to oil lubricated gearbox



# ECO.36+



Watch our machines in action on:  
[www.youtube.com/euroboorby](http://www.youtube.com/euroboorby)



Technical data	
Annular cutting	Ø 12 - 36 mm
Twist drilling (Weldon)	Ø 1 - 14 mm
Countersinking (Weldon)	Ø 10 - 40 mm
In-corner drilling	0° 50 mm centre to edge
	90° 53 mm centre to edge
	45° 60 mm centre to edge
Length	310 mm
Width	135 mm
Height	165 mm
Stroke	40 mm
Weight*	10.3 kg
Magnet (l x w x h)	160 x 80 x 37 mm
Magnetic force	1,200 kg
Motor power	1,050 W
Total power	1,100 W
Speed (no load)	I 700 rpm
Speed (load 1,050 W)	I 400 rpm
Spindle (Weldon)	19.05 mm (3/4")
Voltage	110 - 120 V / 60 Hz
	220 - 240 V / 50 - 60 Hz

\*Exclusive power cord and handle

## Benefits

- One-speed gearbox
- User friendly Quick-Connect cutter fitment system
- Integrated carrying handle and safety strap attachment
- Left and right mount ability of detachable ratchet feed handle
- Integrated tool cooling and lubrication
- Removable and slideable safety guard
- Lubrication bottle with magnet attachment
- Strong dual coil CNC machined 2-way magnet, causing the machine to use less energy, generate less heat and therefore lasts longer
- Reduced risk of damaging machine, tools and workpiece and hurting operator
- Suitable for use in areas and workplaces where power supply is of less quality
- Reduced risk of armature damage
- Reduced risk of control unit(s) damage
- Timely service notification to avoid additional cost by unexpected downtime or unnecessary part replacement



CARBON BRUSH WEAR INDICATOR

INTEGRATED MOTOR CABLE

AUTOMATIC SHUT-OFF

## Features

Power surge protection	Power fluctuation protection	Gyro-Tec	Integrated motor cable
Automatic shut-off	Carbon brush wear indicator	2-way magnet (TempTec)	In-corner: 50 mm

GYRO-TEC  
TEMPTec  
POWER SURGE PROTECTION  
POWER FLUCTUATION PROTECTION

Height: 165 mm

# ECO.36+ / T



Watch our machines in action on:  
[www.youtube.com/euroboorby](http://www.youtube.com/euroboorby)



## Technical data

Annular cutting	Ø 12 - 36 mm
Twist drilling (Weldon)	Ø 1 - 14 mm
Countersinking (Weldon)	Ø 10 - 40 mm
Tapping	M3 - M12
In-corner drilling	0° 50 mm centre to edge
	90° 53 mm centre to edge
	45° 60 mm centre to edge
Length	310 mm
Width	135 mm
Height	165 mm
Stroke	40 mm
Weight*	10.3 kg
Magnet (l x w x h)	160 x 80 x 37 mm
Magnetic force	1,200 kg
Motor power	1,050 W
Total power	1,100 W
Speed (no load)	I 120 - 500 rpm
Speed (load 1,050 W)	I 120 - 400 rpm
Spindle (Weldon)	19.05 mm (3/4")
Voltage	110 - 120 V / 60 Hz
	220 - 240 V / 50 - 60 Hz

\*Exclusive power cord and handle

## Benefits

- One-speed gearbox
- User friendly Quick-Connect cutter fitment system
- Integrated carrying handle and safety strap attachment
- Integrated tool cooling and lubrication
- Removable and slideable safety guard
- Lubrication bottle with magnet attachment
- Strong dual coil CNC machined 2-way magnet, causing the machine to use less energy, generate less heat and therefore lasts longer
- Reduced risk of damaging machine, tools and workpiece and hurting operator
- Suitable for use in areas and workplaces where power supply is of less quality
- Reduced risk of armature damage
- Reduced risk of control unit(s) damage
- Timely service notification to avoid additional cost by unexpected downtime or unnecessary part replacement

CARBON BRUSH  
WEAR INDICATOR

INTEGRATED  
MOTOR CABLE

AUTOMATIC  
SHUT-OFF

## Features



Adjustable speed



R/L rotation



Overload protection



Overheat protection



Power surge protection



Power fluctuation protection



Gyro-Tec



Integrated motor cable



Automatic shut-off



Carbon brush wear indicator



2-way magnet (TempTec)



Tapping



In-corner: 50 mm



Height: 165 mm



GYRO-TEC

TEMPTEC

POWER SURGE PROTECTION

POWER FLUCTUATION PROTECTION

# EBM.36+/P-18V Battery Operated



Watch our machines in action on:  
[www.youtube.com/euroboorby](http://www.youtube.com/euroboorby)



## Technical data

Annular cutting	Ø 12 - 36 mm
Twist drilling	Ø 1 - 13 mm
Countersinking	Ø 10 - 40 mm
Length	325 mm
Width	235 mm
Height	370 - 410 mm
Stroke	140 mm
Weight (incl. batt)*	10.2 kg
Magnet (l x w x h)	157 x 85 x 45 mm
Magnetic force	650 kg
Min. material thickness	6 mm
Motor power	1,000 W
Total power	1,000 W
Speed (no load)	530 rpm
Speed (load)	430 rpm
Spindle (Weldon)	19.05 mm
Battery capacity	18 V 5 Ah Li-ion, 18 V 9 Ah Li-ion

\*Exclusive handles



## Benefits

- Battery-powered motor system
- Integrated carrying handle and safety strap attachment
- Left and right mount ability of detachable feed handle
- Compact and lightweight design
- Based on Makita LXT 18V battery platform
- Integrated tool cooling and lubrication
- Brushless technology

## Magnet benefits

- Permanent, non-electric monobloc magnet system
- No loss of magnetic grip in case of electric power cuts or fluctuations
- Powerful hold, even on thinner steel

## Features



Gyro-Tec



Overload protection



Overheat protection



Integrated motor cable



Permanent magnet



Brushless motor



Magnet LED-indicator (SensorTec)



Battery operated



Makita LXT 18V platform

## Accessories



Batteries 5Ah and 9Ah

EB5A, EB9A



Charger

EBC1

# RAIL.60S



Watch our machines in action on:  
[www.youtube.com/euroboorby](http://www.youtube.com/euroboorby)



## Technical data

Annular cutting	Ø 12 - 36 mm
Length	262 mm
Width	130 mm
Height	597 - 747 mm
Stroke	170 mm
Weight*	14.4 kg
Motor power	1,600 W
Total power	1,700 W
Speed (no load)	I 60 - 275 rpm
	II 100 - 500 rpm
Speed (load 1,600 W)	I 60 - 275 rpm
	II 100 - 500 rpm
Spindle (Weldon)	MT3 19.05 mm (3/4")
Voltage	110 - 120 V / 60 Hz
	220 - 240 V / 50 - 60 Hz

\*Exclusive power cord and handles

## Benefits

- Suitable for processing rails
- High-accuracy capstan hub
- Morse Taper 3 spindle
- Integrated slide for:
  - High accuracy
  - Enlarged lifecycle
  - Minimal vibration
- High-precision height adjustment for:
  - Low maintenance
  - Minimal wear correction



## Features



Adjustable speed



Overheat protection



Oil lubricated gearbox

Optimised motor efficiency and lifetime of key components due to oil lubricated gearbox



Including 6 different rail adapter versions:  
S49, S54, TRC68, UIC50, UIC54 and UIC60.

# PST.2500/3 Powerstation



Watch our machines in action on:  
[www.youtube.com/euroboorby](http://www.youtube.com/euroboorby)



### Technical data

Output voltage	AC 220 V 50/60 Hz
Socket specification	3 x EU type F (grounded) IP44
Rated output power	Max. 3,500 W
Surge power Max.	Max. 7,000 W
Overload protection	Fuse (20 A)
Battery capacity	2.496 Wh
Battery type	Ternary Lithium Ion battery cell
Battery voltage	DC 48 V
Battery cooling	Air (2 x automatic air fans)
Charger voltage	AC 200-240 V 50/60 Hz
Charger output	54.6 V (15 A)
Charging time	± 3.0 hours
Charging cycles	1,500 x (capacity > 80%)
Operating temperature	-20°C up to 40°C
Charging temperature	0°C up to 30°C
Storage temperature	0°C up to 25°C
Dimensions (L x W x H)	550 x 310 x 460 mm
Weight	28.3 kg
Ingress protection class	IP21S (indoor)

### Features

- Continuous load of 3,500 W
- Peak load of 7,000 W
- High Capacity Ternary Lithium Ion Cells
- Fast rechargeable (3 hours)
- 3 power outlets 220 V
- Electricity supply without fluctuations
- Can be used practically everywhere
- Easy to use
- Ideal for heavy duty industrial power tools
- No noise, no smell, no pollution



**100%**  
**CHARGED**  
**3**  
**HOURS**



# Accessories

We are convinced accessories are auxiliary tools. Their development follows from practical situations in which challenges and problems present themselves; problems which could have been prevented by properly estimating the diversity and complexity of the work.

After more than 40 years of practical experience we dare to say we are familiar with most challenges that you may encounter. Euroboor accessories have been developed for direct practical solutions and comfort at work. Non-magnetic base, horizontal drilling or lack of space, you can proceed undisturbed at all times.

Our accessories are professional solutions that are specifically designed for and tuned to your activities.

## Practical solutions for comfort at work

**“Our vision is focused on developing accessories that add value and facilitate you in your daily work”.**

# Weldon setup overview

— Absolute connection    ..... Optional connection

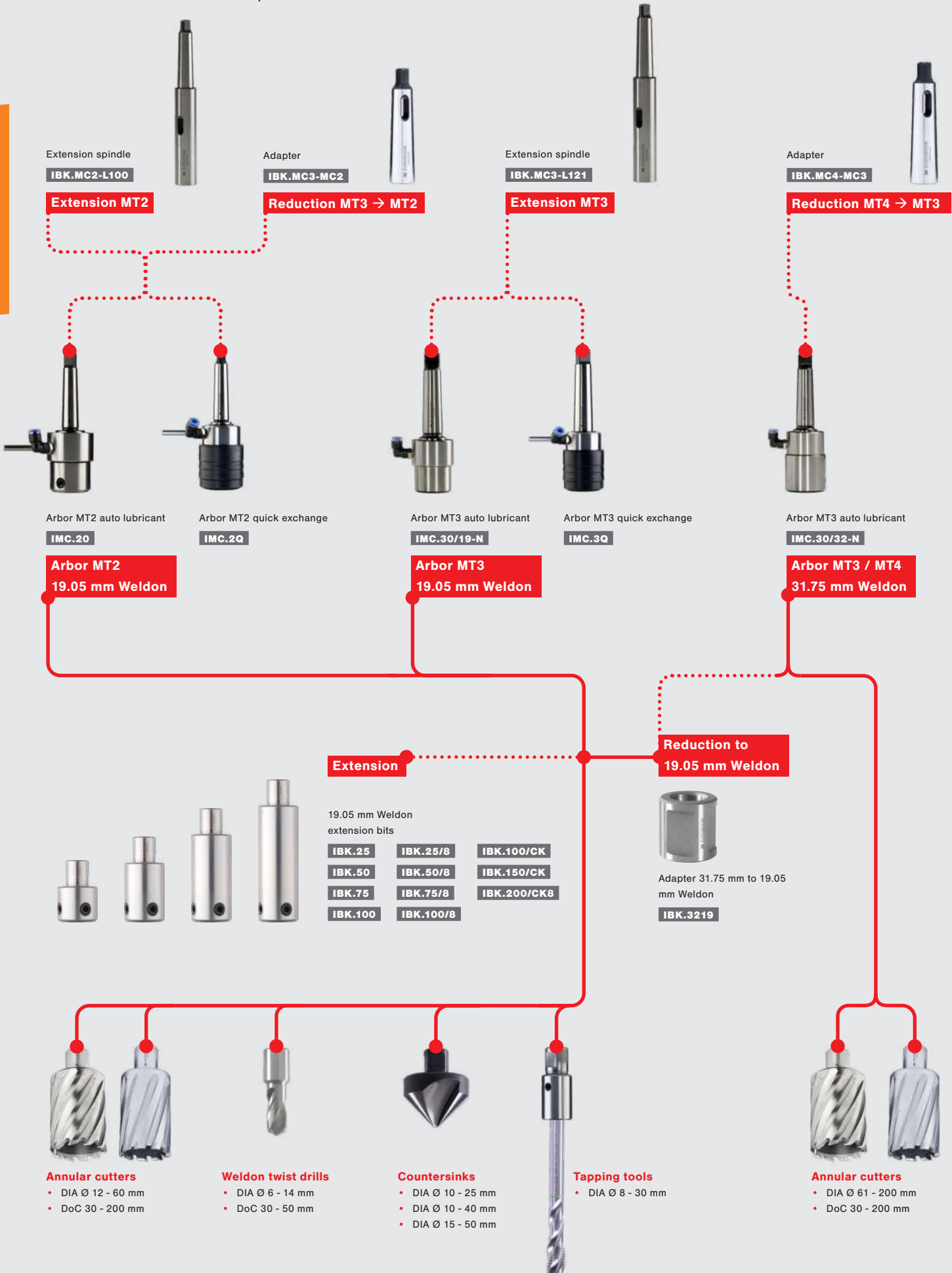

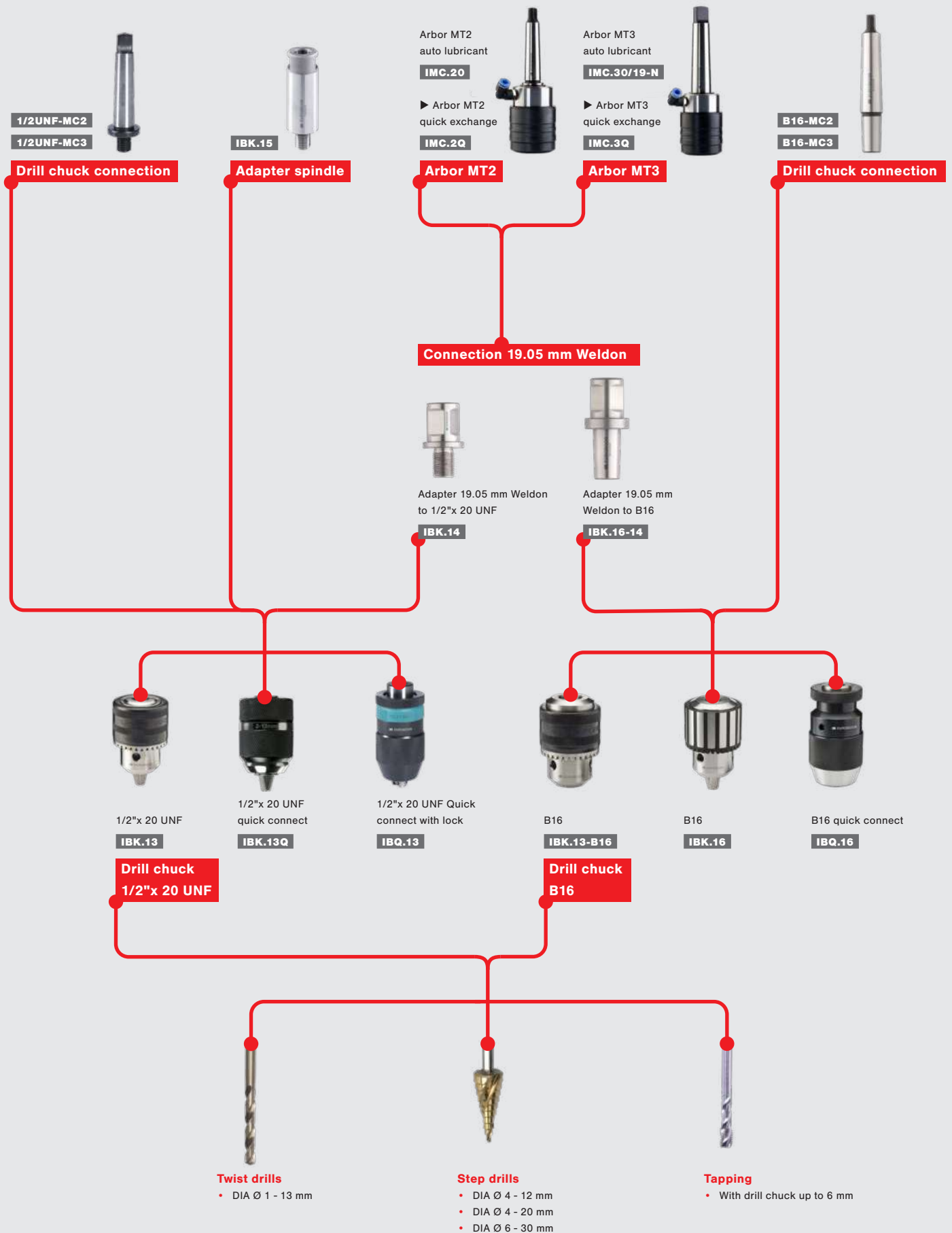



# Armature kit

The armature kit consists of original parts for the maintenance of your magnetic core drill. We therefore recommend that you only use this official Euroboor kit to maintain your machine warranty. There is a suitable armature kit for all Euroboor magnetic core drilling machines.

## Total package

The use of all spare parts from this total package ensures that the lifespan of your magnetic drilling machine can be extended by factor four to five. In addition, hidden maintenance costs are kept to a bare minimum and you maintain your machine warranty. After maintenance with the armature kit, the magnetic drilling machine operates as new again.

The armature kit with original Euroboor spare parts consists of:

- Armature
- Bearing(s)\*
- Circlip
- First gear
- Carbon brush set

## ARM.KIT

\* Depending on machine the number and type of bearings may vary.

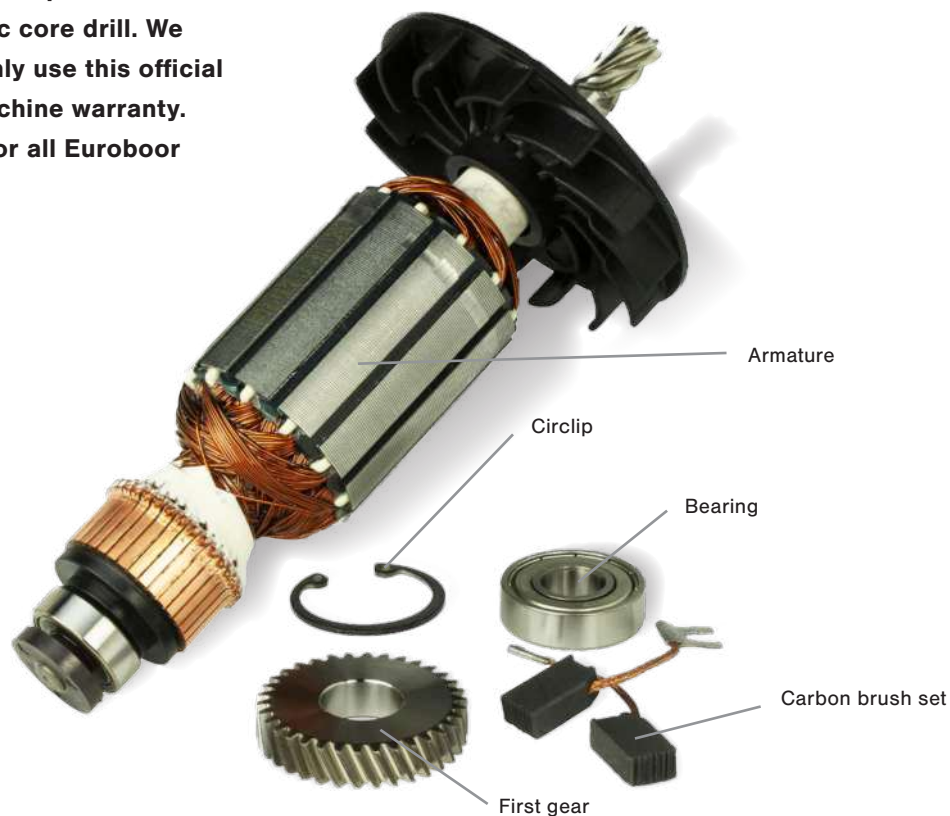



Watch our machines in action on:  
[www.youtube.com/euroboorbv](http://www.youtube.com/euroboorbv)



## WelNit kit

- The WelNit Kit gives you the possibility to connect every type of cutter with your Magnetic Drilling Machine
- The One Touch Arbor gives you the advantage of fast and safe cutter changes. The cutter has a tight fit which gives you less vibrations during the cutting process
- For every cutter length you have the right pilot pin in the box
- Packed in luxury case

### The WelNit kit consists of:

- **Morse taper Nitto:** morse taper for placement in a Core drilling machine and the use of a Nitto One-Touch
- **2 Adapters one-Touch Nitto-3/4" Weldon:** adapter to place a drill with Weldon recording in a drill with Nitto one Touch recording.  
Includes 6 mm and 8 mm hole for a Pilot pin
- **Adapter 19.05 mm WelNit - 1/2" x 20 UNF:** adapter to place a drill head with 20 UNF connection in a drill with Nitto one Touch connection
- **Drill chuck quick change 13mm 1/2" x 20 UNF:** drill head for the use of twist drills with a round or 3 flat shank up to 13 mm
- **9 Different pilot pins** for placing the drill in the correct position and pushing out the slug:  
 Ø 6.35 x 90 mm, Ø 6.35 x 102 mm, Ø 6.35 x 120 mm,  
 Ø 6.35 x 127 mm, Ø 6.35 x 155 mm, Ø 8.0 x 103 mm,  
 Ø 8.0 x 122 mm, Ø 8.0 x 128 mm, Ø 8.0 x 165 mm



### Content MC3 kit:

- IMC.3 NITTO
- IBK.NIT
- IBK.NIT/8
- IBK.14/NIT
- IBQ.13
- IBC.75
- IBC.80
- IBC.90
- IBC.100
- IBC.130
- IBC.K25
- IBC.K50
- IBC.128
- IBC.120

WELNIT-KIT.MC3

### Content MC2 kit:

- IMC.2 NITTO
- IBK.NIT
- IBK.NIT/8
- IBK.14/NIT
- IBQ.13
- IBC.75
- IBC.80
- IBC.90
- IBC.100
- IBC.130
- IBC.K25
- IBC.K50
- IBC.128
- IBC.120

WELNIT-KIT.MC2

## Adapters

### Pipe Adapter kit

- Suitable for tube diameter from  $\varnothing$  50 mm up to 500 mm
- Suitable for all Euroboor magnetic drilling machines (except ECO.200 & TUBE serie)
- Suitable for almost all drilling machines in the market (for universal use)

#### Dimensions PAK.250

Length: 286 mm  
Width: 268 mm  
Height: 96 mm

#### Dimensions inside plate

Length: 265 mm  
Width: 112 mm  
Height: 14 mm

#### Weight

12.5 kg

**PAK.250**



### Vacuum Adapter kit $\varnothing$ 300 mm

including pump

- Dimensions:  $\varnothing$  300 mm

**VAC.810**



### Vacuum Adapter kit oval

Clamp system with 2 suction pads including pump

- Dimensions: 450 x 250 mm

**VAC.820**



### Components also available separately

#### Vacuum pump

- Power: 1/2 hp
- Inlet port: 1/4" flare & 3/8" flare
- Ultimate vacuum:  $3 \times 10^{-1}$  Pa, 25 microns
- Flow rate: 5 CFM, 142 l/min (110V)  
4.5 CFM, 128 l/min (220V)
- Voltage: 110 - 120 V / 220 - 240 V / 50 - 60 Hz

**VAC.001**

#### Vacuum plate round $\varnothing$ 300 mm

**VAC.002**

#### Vacuum plate oval $\varnothing$ 450 x 250 mm

**VAC.003**

## Extensions



### Extension Weldon 25 mm

19.05 mm (3/4") Weldon, 25 mm (1") extension, outer Ø 35 mm (1 3/8")  
For 6.35 mm (1/4") pilot pins

**IBK.25**

For 8 mm (5/16") pilot pins

**IBK.25/8**

### Extension Weldon 50 mm

19.05 mm (3/4") Weldon, 50 mm (2") extension, outer Ø 35 mm (1 3/8")  
For 6.35 mm (1/4") pilot pins

**IBK.50**

For 8 mm (5/16") pilot pins

**IBK.50/8**

### Extension Weldon 75 mm

19.05 mm (3/4") Weldon, 75 mm (2 15/16") extension, outer Ø 35 mm (1 3/8")  
For 6.35 mm (1/4") pilot pins

**IBK.75**

For 8 mm (5/16") pilot pins

**IBK.75/8**

### Extension Weldon 100 mm

19.05 mm (3/4") Weldon, 100 mm (3 15/16") extension, outer Ø 35 mm (1 3/8")  
For 6.35 mm (1/4") pilot pins

**IBK.100**

For 8 mm (5/16") pilot pins

**IBK.100/8**

### MT2 - 100 mm extension

MT2 - MT2

**IBK.MC2-L100**

### MT3 - 250 mm extension

MT3 - MT3

**IBK.MC3-L250**

### MT3 - 121 mm extension

MT3 - MT3

**IBK.MC3-L121**

### MT3 - 450 mm extension

MT3 - MT3

**IBK.MC3-L450**



### Extreme Thin Extension

#### Weldon 100 mm

19.05 mm (3/4") Weldon, 100 mm (4") extension, outer Ø 26 mm (1 1/32")

For 6.35 mm (1/4"),

8 mm (5/16") pilot pins

**IBK.100/CK**

### Extreme Thin Extension

#### Weldon 150 mm

19.05 mm (3/4") Weldon, 150 mm (6") extension, outer Ø 26 mm (1 1/32")

For 6.35 mm (1/4"),

8 mm (5/16") pilot pins

**IBK.150/CK**

### Extreme Thin Extension

#### Weldon 200 mm

19.05 mm (3/4") Weldon, 200 mm (8") extension, outer Ø 26 mm (1 1/32")

For 6.35 mm (1/4"),

8 mm (5/16") pilot pins

**IBK.200/CK**



## Connections



### Adapter Nitto One Touch

(external) to 19.05 mm (3/4") Weldon (internal)

**IBK.NIT**



### Adapter Fein Quick-In

(external) to 19.05 mm (3/4") Weldon (internal)

**IBK.QFN**



### Adapter 19.05 mm Weldon

(external) to 1/2" x 20 UNF

**IBK.14**



### Adapter 19.05 mm Weldon

(external) to B16 drill chuck connection

**IBK.16-14**



### Reduction Ring

31.75 mm (1 1/4") Weldon (external) to 19.05 mm (3/4") Weldon (internal)

**IBK.3219**

## Morse Taper reductions



### Morse Taper reduction

MT3 (machine) to MT2 (tool holder)

**IBK.MC3-MC2**



### Morse Taper reduction

MT4 (machine) to MT3 (tool holder)

**IBK.MC4-MC3**

Arbors



MC.2 / MC.3

Auto Arbor IMC.2Q / IMC.3Q



MC.3/32



IMC.30/19-N / IMC.30/32-N



Nitto 2 / 3

**Arbor MT2 - 19.05 mm (3/4") Weldon**  
For cutters Ø 12 - 60 mm

**MC.2**

**Arbor MT2 - 19.05 mm (3/4") Weldon**  
Including lubrication ring

**IMC.20**

**Auto Arbor MT2 - 19.05 mm (3/4") Weldon**  
Including lubrication ring  
Quick exchange, Weldon connection

**IMC.2Q**

**Arbor MT3 - 19.05 mm (3/4") Weldon**  
For cutters Ø 12 - 60 mm

**MC.3**

**Arbor MT3 - 19.05 mm (3/4") Weldon**  
For cutters Ø 12 - 60 mm  
With extended shaft, including lubrication ring

**MC.3-75**

**Arbor MT3 - 19.05 mm (3/4") Weldon**  
Including lubrication ring

**IMC.30/19-N**

**Auto Arbor MT3 - 19.05 mm (3/4") Weldon**  
Including lubrication ring  
Quick exchange, Weldon connection

**IMC.3Q**

**Arbor MT3 - 31.75 mm (1 1/4") Weldon**  
For cutters Ø 61 - 100 mm

**MC.3/32**

**Arbor MT3 - 31.75 mm (1 1/4") Weldon**  
Including lubrication ring

**IMC.30/32-N**

**Arbor MT4 - 31.75 mm (1 1/4") Weldon**  
Including lubrication ring

**IMC.40/32**

**Arbor MT4 - 31.75 mm (1 1/4") Weldon**  
Including lubrication ring

**ECO200.MC4/32**

**Arbor Nitto MT2 - 19.05 mm (3/4") Weldon**  
For Nitto cutters, Including lubrication ring

**IMC.2 NITTO**

**Arbor Nitto MT3 - 19.05 mm (3/4") Weldon**  
For Nitto cutters, Including lubrication ring

**IMC.3 NITTO**



**Adapter 1/2" x 20 UNF (external) to 1/2" x 20 UNF (internal) extension adapter for drill chucks fitting length 65 mm**

**IBK.15**



Assembly of a shorter extension adapter IBK.15 for use with drill chucks.

**Benefit:**  
**increases space for twist drills**

IBK.15 with a drill chuck IBQ.13Q for illustration purpose

## Drill chuck connections



**Morse Taper 2 to B16**  
Spindle connection  
**B16-MC2**



**Morse Taper 3 to B16**  
Spindle connection  
**B16-MC3**



**Morse Taper 2 to 1/2" x 20 UNF**  
Spindle connection  
**1/2UNF-MC2**



**Morse Taper 3 to 1/2" x 20 UNF**  
Spindle connection  
**1/2UNF-MC3**

**Morse Taper 2 to B18**  
Spindle connection  
**B18-MC2**

**Morse Taper 3 to B18**  
Spindle connection  
**B18-MC3**

## Twist drill chucks



**Drill chuck**  
DIA Ø 1.5 - 13 mm,  
1/2" x 20 UNF connection  
**IBK.13**



**Drill chuck quick connect**  
DIA Ø 2 - 13 mm  
1/2" x 20 UNF connection  
Keyless  
**IBK.13Q**



**Drill chuck**  
DIA Ø 1.5 - 13 mm  
B16 connection  
**IBK.13-B16**



**Drill chuck**  
DIA Ø 1.5 - 16 mm  
B16 connection  
**IBK.16**



**Drill chuck quick connect**  
DIA Ø 1.5 - 13 mm  
1/2" x 20 UNF connection  
Keyless  
**IBQ.13**



**Drill chuck quick connect**  
DIA Ø 1.5 - 16 mm  
B16 connection  
Keyless  
**IBQ.16**

The IBQ.13 and IBQ.16 Quick connect drill chucks are keyless, three-jaw, self-centering chucks that hold drill bits in place during drilling tasks. They can be used with magnetic drilling machines together with Euroboor accessories like IBK.14, IBK.15 and 1/2" x 20 UNF Morse Taper.

# Cutting lubricants

Euroboor spends a lot of time and effort on pushing boundaries to make your drilling process far more efficient. This continuous research and development is reflected in superior quality magnetic drilling machines, annular cutters and all other kinds of tools and accessories. While this lays the basis for optimum drilling and cutting performance, there is also the hugely important, often underestimated, factor of proper cooling and lubrication.

However sharp, stable or fast a cutting tool may be, working with metal is a demanding job which generates friction and heat, impacting end result, processing time and durability.

**Lubrication**

A suitable lubricant will reduce friction greatly. The tool will set itself much better and will generate less vibrations. A smoother operation means less power needs to be put into the job, the finished result will be more precise and operation time can be reduced by up to 30%.

**Cooling**

Processing metals can, as generally known, produce a lot of heat. Overheating can have serious negative effects on the behaviour of the workpiece and tool, and thus the overall performance. The result is generally an increased processing time, but not being

able to complete the job might even be possible as well. Inappropriate cooling can lead to specific issues, such as unreliable slug ejection when working with annular cutters.

**Protection**

For example, think about the discolouration of your metal workpiece or about the sizing accuracy of drilled holes after cooling down. When pushing your cutting tools fast and hard, burning them up might even be possible quicker than you would have imagined. With the use of appropriate lubrication and cooling you are able to actively protect the workpiece and used tools.

**Durability**

Making sure a cutting tool is able to perform smoothly and constantly by proper cooling and lubrication will increase its

functional life significantly. Taking annular cutting as an example, both the drilling machine and cutter will benefit from the drastically reduced stress. Depending on circumstances, an annular cutter can last up to 5 times longer when properly taken care of during operation!

**Our offering**

Euroboor offers a wide range of well-considered cooling and lubrication products to match your requirements. If you are processing high-tensile strength stainless steel or need to cut a plain aluminium bar, create large-bore holes or prepare a fine-coarse thread, whether working on a drilling line or in difficult spots on location, we can help you out with just the right lubricant.

## The use of appropriate cutting lubricant adds value to your business operation

- Higher quality workpiece finishing
- Minimised tool wear and replacement
- Reduced processing time & lower operation cost

Material application		● Optimal	● Good	● Possible											
Oil	Material	Plastics GRP/CRP	Brass, Copper, Tin	Grey cast iron	Steel					Stainless steel		Aluminium		Exotic materials*	Rails
					< 500N	< 750N	< 900N	< 1,100N	< 1,400N	< 900N	≤ 900N	< 10% Si	≤ 10% Si		
IBO.10		○	○	○	●	●	●	●	●	○	○	○	○	○	○
IBO.P911		○	○	○	●	●	●	●	●	○	○	○	○	○	○
IBO.20		○		●	○	○	○	○	○	●	●			●	●
IBO.50		○	●	○	○	○	○	○	○	○	○	●	●	○	○
IBO.60		○	○	○	●	●	●	●	●	○	○	○	○	○	○
MV.4		○	○	○	●	●	●	●	●	○	○	○	○	○	○
IBO.30		○	○	○	●	●	●	●	●	○	○	○	○	○	○
IBP.70				●	●	●	●	●	●	●	●			●	●

This overview only offers an indication of use. Further information on lubrication and material behaviour on request. Always try the chosen cutting lubricant on a test piece first.

\* Inconnell, Nimonic, HARDOX and Hastelloy

## Cutting oils

### General usage

#### IBO.10

##### Mild steel lubricating and cooling cutting oil

General cutting oil offering premium cooling and lubrication for most common mild steel projects. High-cutting power tool preservation and improved processing times.

**IBO.1001 (1 litre)**

**IBO.1050 (5 liters)**



Watch our machines in action on:  
[www.youtube.com/euroboorby](http://www.youtube.com/euroboorby)



#### MV.4

##### All metals lubricating and cooling concentrate

User and environmentally friendly water-soluble cooling and lubricating concentrate. Particularly suitable for automatic dosing systems, offering efficient cooling on the majority of metal workpieces. No harmful mist formation and economical in use (can be diluted up to 1:20 ratio).

**MV.4001 (1 litre)**

**MV.4050 (5 liters)**



## Cutting spray oils



#### IBO-P.911

##### Biodegradable Mild steel lubricating and cooling cutting oil spray

Premium metal processing cooling and lubrication in spray can form, suitable for use on mild steel.

Highly versatile in use and ideal for tool preparation.

**IBO-P.911.500 (500 ml)**



#### IBO.30

##### All metals lubricating and cooling cutting oil spray

Versatile spray with high-cooling and evaporation properties. Ideal for the (after) cooling of all workpieces and tools. The minimal harmful contents and minimal greasy residue facilitate further proceedings with the workpiece.

**IBO.30 (500 ml)**

The design and appearance of some components may change due to constantly ongoing development and improvement.

## Gearbox oil

### IBO.G1

Offered as official Euroboor spare part, IBO.G1 is the recommended oil for Euroboor magnetic drilling machines with oil lubricated gearboxes. This is the only gear lubricant which is able to meet our high-requirements for operating temperature, minimal wear and high-machine efficiency.

#### For use with:

ECO.30S+, ECO.40S, ECO.40S+, ECO.50S, ECO.50S+, ECO.55S/T, ECO.55S+/T, ECO.55S+/TA, ECO.60S, ECO.60S+, ECO.80S+, ECO.100S+/T, ECO.100S+/TD, TUBE.30S+ and TUBE.55S/T, TUBE.55S+/T.

**IBO.G101 (1 litre)**

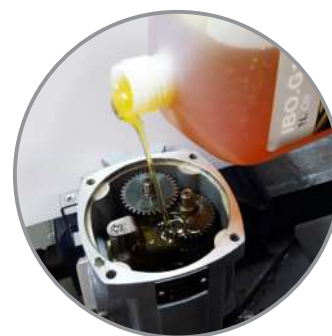

## Paste

### IBP.70

#### High-alloy steel cutting paste

A cutting compound for metal, with strong adhesive strength on materials and tools, for vertical and upside down applications where liquid metal working oils can't be used. Based on mineral oil with carefully selected extreme pressure additives with excellent lubricating properties for low tool wear and excellent surface quality. Suitable for drilling, milling, tapping, threading and punching of high-alloy steel grades.

**IBP.70 (1 liters)**



## Multifunctional oil spray

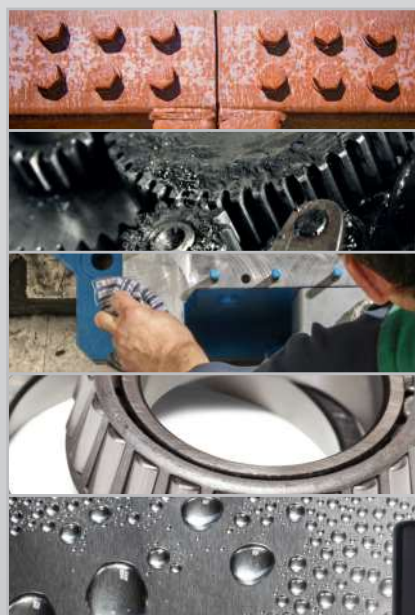

#### Operational use:

- Rust removing
- Lubricating
- Contact improving
- Cleaning
- Corrosion protective
- Moisture repellent

### IBO.40

Universal problem solving and preventing spray, suitable for the maintenance of tools and other moving parts. Also suitable as protector of electronics. Does not contain silicones, water or graphite.

**IBO.40 (400 ml)**



# Euroboor

## Annular cutters



Watch our machines in action on:  
[www.youtube.com/euroboorby](http://www.youtube.com/euroboorby)



### Annular cutters

- + Longer lifespan
- + Exact dimensions
- + Unique teeth geometry
- + Optimum chip clearance
- + Superior slug ejection



### High-precision shanks, various connections



**Weldon**  
19.05 mm (3/4")



**WelNit**  
19.05 mm (3/4")



**Weldon**  
31.75 mm (1 1/4")

### Pilot pins

Pilot pins are essential for the use of annular cutters, as they provide the following practical uses:

- **Centration of cutter**
- **Control of oil flow**
- **Slug ejection**



1. Pilot pin
2. Annular cutter
3. Pilot pin inside annular cutter
4. Place in arbor magnetic drilling machine and commence drilling



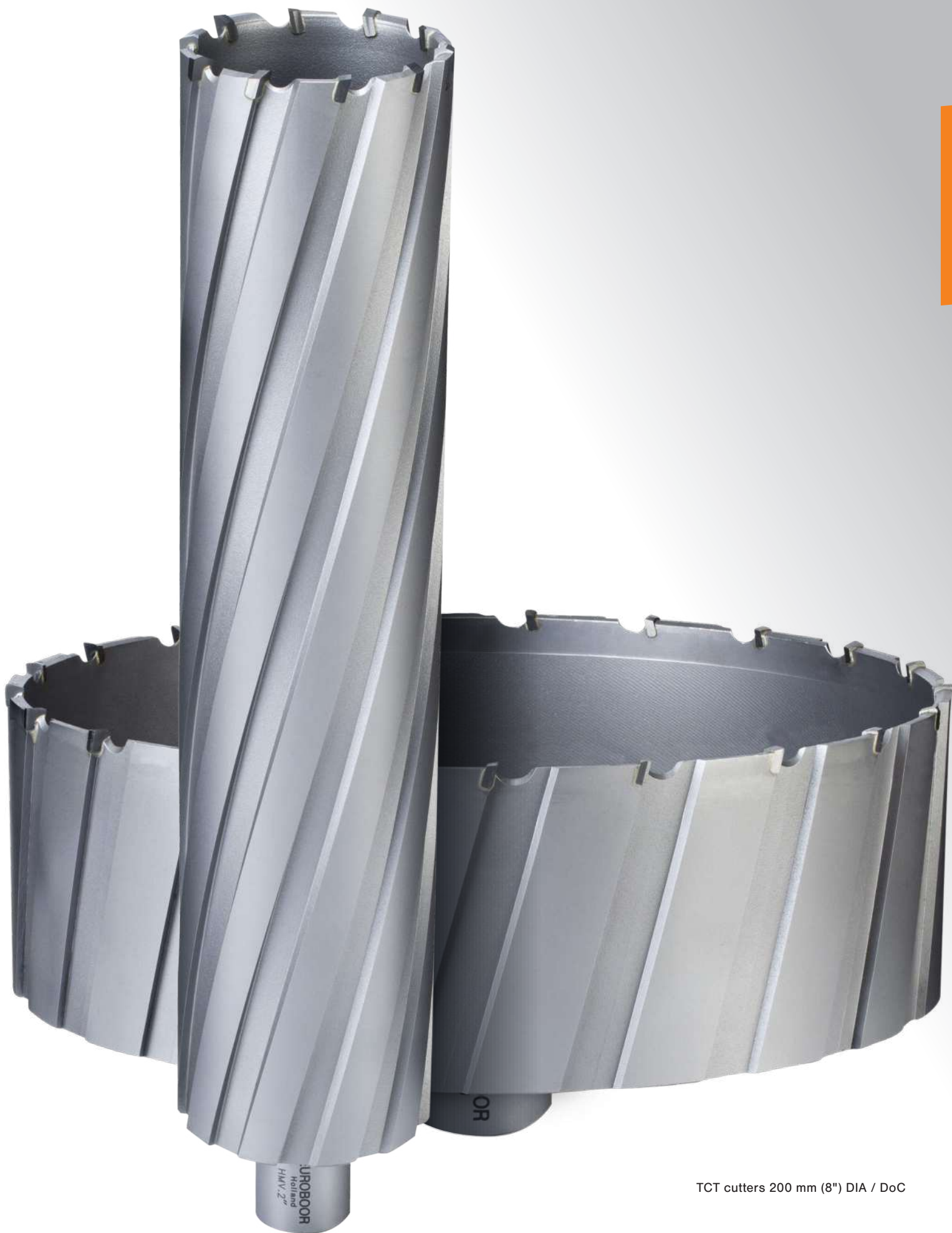

TCT cutters 200 mm (8") DIA / DoC

# Euroboor annular cutter portfolio

## Geometry

### Altering cutting teeth angles for precise and clear cuts

On our HSS and TCT cutters every tooth does its own job, working together to cut cleaner and quicker. They actually save time!



TCT cutters have three different teeth



HSS cutters have two different teeth

## Did you know?

- With the **right lubrication** tool life is drastically improved;
- Drilling with cutters is best with **internal cooling**;
- A **perfect fitting pilot pin** prevents cutter breakage;
- **TCT cutters need a higher speed** than HSS cutters;
- Euroboor HSS cutters have an extra landing on the outside and cut more accurate with **less friction**;
- Euroboor cutters have a grounded inside **which offers expansion room to slug**;
- Metric & imperial **specific sizes** and **shank variations** can be supplied on request.

Weldon shank

## Shank

Euroboor annular cutters are standard equipped with **high-precision Weldon shanks**. Depending on the cutter size and specification; 19.05 mm (3/4") or 31.75 mm (1 1/4"). Additionally we also offer cutters with double shank design. These annular cutters have an increased practical application, as they are suitable for use on machinery requiring Weldon fitment as well as machinery with Nitto fitment.

WeINit shank

# The No. 1 choice in HSS, HSS-Cobalt and TCT

We offer a well-considered range of annular cutters, designed to exceed your requirements. Many years of our hands-on experience are reflected in the unique features of our cutters. We do not compromise on quality and for that reason our cutters are appreciated worldwide for optimum performance, durability and longer functional life in all industries. From small scale fabrication to the oil and shipping industry, and from large scale fabrication to construction, and beyond.



## Annular cutter overview

Depth of Cut (DoC)				Ø Metric (mm) Weldon	Ø Metric (mm) WelNit	Ø Imperial (inch) Weldon	Ø Imperial (inch) WelNit
25 mm	1"	TCT Rail		17 - 36	-	-	-
30 mm	1"	HSS		12 - 100	12 - 60	7/16" - 4"	-
30 mm	1"	HSS-Cobalt	8%	12 - 60	-	7/16" - 2 5/16"	-
35 mm	1"	TCT		12 - 100	12 - 60	7/16" - 4"	7/16" - 2 5/16"
35 mm	1"	TCT Rail		17 - 36	-	-	-
55 mm	2"	HSS		12 - 100	12 - 60	7/16" - 4"	7/16" - 2 5/16"
55 mm	2"	HSS Stack		18 - 32	-	11/16" - 1 1/4"	-
55 mm	2"	HSS-Cobalt	8%	12 - 60	-	7/16" - 2 5/16"	-
55 mm	2"	TCT		12 - 200	12 - 60	7/16" - 8"	7/16" - 2 5/16"
75 mm	3"	HSS		14 - 50	-	-	-
75 mm	3"	HSS Stack		18 - 32	-	11/16" - 1 1/4"	-
75 mm	3"	HSS-Cobalt	8%	-	-	7/16" - 2 5/16"	-
75 mm	3"	TCT		12 - 50	-	7/16" - 3"	-
100 mm	4"	HSS		18 - 50	-	-	-
100 mm	4"	TCT		12 - 200	-	7/16" - 8"	-
150 mm	6"	TCT		22 - 200	-	7/8" - 8"	-
200 mm	8"	TCT		22 - 200	-	7/8" - 8"	-

Material appliance		● Optimal ○ Good ○ Possible			Material					Stainless steel		Aluminium		Exotic materials*	Rails
Cutter	Material	Plastics GRP/ CRP	Brass, Copper, Tin	Grey cast iron	Steel					Stainless steel		Aluminium		Exotic materials*	Rails
					< 500N	< 750N	< 900N	< 1,100N	< 1,400N	< 900N	≤ 900N	< 10% Si	≤ 10% Si		
HSS		●	○		●	●	○					○			
HSS-Cobalt		●	●	○	●	●	●	○	○	○	○	●	○	○	
TCT			○	●	●	●	●	●	●	●	●	●	●	●	○
TCT Rail			○	●	●	●	●	●	●	●	●	●	●	●	●

\* Inconnell, Nimonic, HARDOX, Hastelloy

## Annular cutter

# High Speed Steel



HSS annular cutters, with unique teeth geometry, provide clear cutting, fast feed rate, less vibration, smooth hole surface and long tool life. They are better and quicker than twist drills. HSS annular cutters can be used on all kinds of magnetic drilling machines. They can be widely used in drilling steel, copper, aluminium, stainless

steel and plastic, in either plate or pipe form. The HSS annular cutters have gained huge popularity in the market. The entire range is available in various specifications that can be customised as per your requirements.

HSS material application												
Plastics GRP/CRP	Brass, Copper, Tin	Grey cast iron	Steel				Stainless steel		Aluminium		Exotic materials, Inconnell, Nimonic, HARDOX, Hastelloy	Rails
			< 500N	< 750N	< 900N	< 1,100N	< 1,400N	< 900N	≤ 900N	< 10% Si		
●	○		●	●	○					○		

## HSS profile

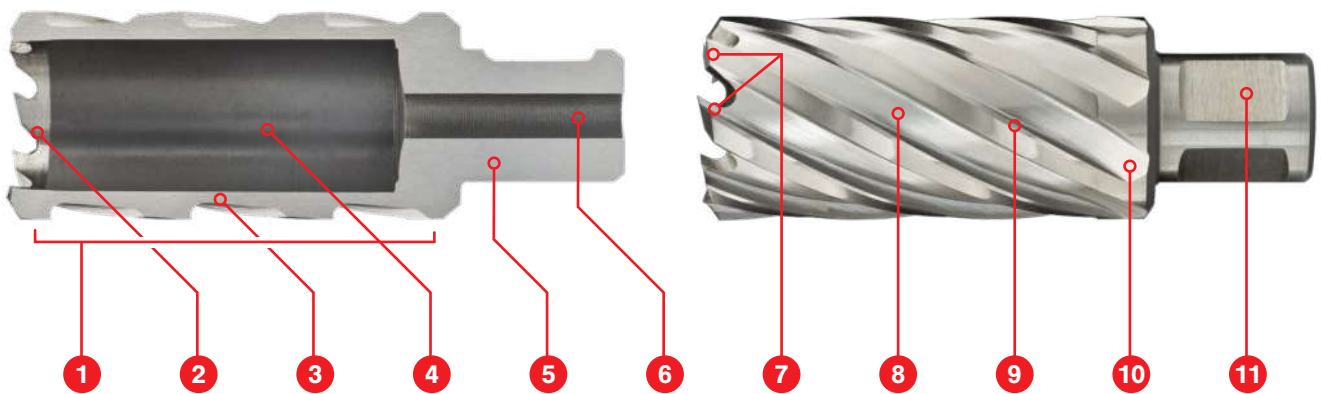

1. Stage hardening. Combines maximum hardness at the teeth with superior strength at the cutter body, reducing breakage to a minimum.
2. Inner ground cutting teeth. Helps stable "setting" of the cutter, reduces friction during drilling and helps slug ejection.
3. Wall thickness matched to the diameter of the cutter, combining the best possible cutting time with strength.
4. Tapered inside fitment prevents the cutter getting stuck. Guaranteed slug ejection with usage of the correct pilot pin.
5. Precise shank fitment for maximum interchangeability and close tolerance drilling without run-out.
6. Precise pilot pin fitment for perfect centration, hassle-free pin retraction and controlled lubricant flow.
7. Altering "continuous pre-cut" teeth geometry. Generates faster and more stable drilling performance and results in clear cuts of the highest precision and smooth, burr-free finishes.
8. Well-thought-out spiral flute angles for optimal chip removal.
9. Specially designed blades for optimum stability and heat-reduction.
10. Number of flutes and teeth matched to the diameter of the cutter for the best tooth load and superior cutting speeds.
11. Precision ground shanks for optimum fitment of the cutter itself in the tool holder and of pilot pin in the annular cutter. Increases safety, stability and accurate hole dimensions.

	DoC 30 mm Weldon	DoC 30 mm Universal	DoC 55 mm Weldon	DoC 55 mm Universal	DoC 75 mm Weldon	DoC 100 mm Weldon
DIA	Ø 12 - 100 mm	Ø 12 - 60 mm	Ø 12 - 100 mm	Ø 12 - 60 mm	Ø 14 - 50 mm	Ø 18 - 50 mm
	Code	Code	Code	Code	Code	Code
Ø 12	HCS.120	HCSU.120	HCL.120	HCLU.120	HCY.120	HCX.120
Ø 13	HCS.130	HCSU.130	HCL.130	HCLU.130	HCY.130	HCX.130
Ø 13.5	HCS.135		HCL.135			
Ø 14	HCS.140	HCSU.140	HCL.140	HCLU.140	HCY.140	HCX.140
Ø 15	HCS.150	HCSU.150	HCL.150	HCLU.150	HCY.150	HCX.150
Ø 15.5	HCS.155		HCL.155			
Ø 16	HCS.160	HCSU.160	HCL.160	HCLU.160	HCY.160	HCX.160
Ø 17	HCS.170	HCSU.170	HCL.170	HCLU.170	HCY.170	HCX.170
Ø 17.5	HCS.175		HCL.175			
Ø 18	HCS.180	HCSU.180	HCL.180	HCLU.180	HCY.180	HCX.180
Ø 19	HCS.190	HCSU.190	HCL.190	HCLU.190	HCY.190	HCX.190
Ø 19.5	HCS.195		HCL.195			
Ø 20	HCS.200	HCSU.200	HCL.200	HCLU.200	HCY.200	HCX.200
Ø 21	HCS.210	HCSU.210	HCL.210	HCLU.210	HCY.210	HCX.210
Ø 21.5	HCS.215		HCL.215			
Ø 22	HCS.220	HCSU.220	HCL.220	HCLU.220	HCY.220	HCX.220
Ø 23	HCS.230	HCSU.230	HCL.230	HCLU.230	HCY.230	HCX.230
Ø 24	HCS.240	HCSU.240	HCL.240	HCLU.240	HCY.240	HCX.240
Ø 25	HCS.250	HCSU.250	HCL.250	HCLU.250	HCY.250	HCX.250
Ø 26	HCS.260	HCSU.260	HCL.260	HCLU.260	HCY.260	HCX.260
Ø 26.5	HCS.265		HCL.265			
Ø 27	HCS.270	HCSU.270	HCL.270	HCLU.270	HCY.270	HCX.270
Ø 28	HCS.280	HCSU.280	HCL.280	HCLU.280	HCY.280	HCX.280
Ø 29	HCS.290	HCSU.290	HCL.290	HCLU.290	HCY.290	HCX.290
Ø 30	HCS.300	HCSU.300	HCL.300	HCLU.300	HCY.300	HCX.300
Ø 31	HCS.310	HCSU.310	HCL.310	HCLU.310	HCY.310	HCX.310
Ø 32	HCS.320	HCSU.320	HCL.320	HCLU.320	HCY.320	HCX.320
Ø 33	HCS.330	HCSU.330	HCL.330	HCLU.330	HCY.330	HCX.330
Ø 34	HCS.340	HCSU.340	HCL.340	HCLU.340	HCY.340	HCX.340
Ø 35	HCS.350	HCSU.350	HCL.350	HCLU.350	HCY.350	HCX.350
Ø 36	HCS.360	HCSU.360	HCL.360	HCLU.360	HCY.360	HCX.360
Ø 37	HCS.370	HCSU.370	HCL.370	HCLU.370	HCY.370	HCX.370
Ø 38	HCS.380	HCSU.380	HCL.380	HCLU.380	HCY.380	HCX.380
Ø 39	HCS.390	HCSU.390	HCL.390	HCLU.390	HCY.390	HCX.390
Ø 40	HCS.400	HCSU.400	HCL.400	HCLU.400	HCY.400	HCX.400
Ø 41	HCS.410	HCSU.410	HCL.410	HCLU.410	HCY.410	HCX.410
Ø 42	HCS.420	HCSU.420	HCL.420	HCLU.420	HCY.420	HCX.420
Ø 43	HCS.430	HCSU.430	HCL.430	HCLU.430	HCY.430	HCX.430
Ø 44	HCS.440	HCSU.440	HCL.440	HCLU.440	HCY.440	HCX.440
Ø 45	HCS.450	HCSU.450	HCL.450	HCLU.450	HCY.450	HCX.450
Ø 46	HCS.460	HCSU.460	HCL.460	HCLU.460	HCY.460	HCX.460
Ø 47	HCS.470	HCSU.470	HCL.470	HCLU.470	HCY.470	HCX.470
Ø 48	HCS.480	HCSU.480	HCL.480	HCLU.480	HCY.480	HCX.480
Ø 49	HCS.490	HCSU.490	HCL.490	HCLU.490	HCY.490	HCX.490
Ø 50	HCS.500	HCSU.500	HCL.500	HCLU.500	HCY.500	HCX.500
Ø 51	HCS.510	HCSU.510	HCL.510	HCLU.510		
Ø 52	HCS.520	HCSU.520	HCL.520	HCLU.520		
Ø 53	HCS.530	HCSU.530	HCL.530	HCLU.530		
Ø 54	HCS.540	HCSU.540	HCL.540	HCLU.540		
Ø 55	HCS.550	HCSU.550	HCL.550	HCLU.550		
Ø 56	HCS.560	HCSU.560	HCL.560	HCLU.560		
Ø 57	HCS.570	HCSU.570	HCL.570	HCLU.570		
Ø 58	HCS.580	HCSU.580	HCL.580	HCLU.580		
Ø 59	HCS.590	HCSU.590	HCL.590	HCLU.590		



Weldon shank



Universal shank



Shank sizes

DIA Ø 12 - 60 mm:  
19.05 mm (3/4")

DIA Ø 61 - 100 mm:  
31.75 mm (1 1/4")

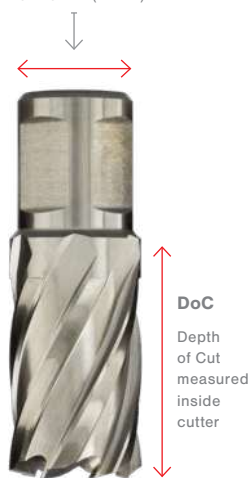

DoC 75 mm (HCY)

DIA Ø 51 - 100 mm:  
Available on request

DoC 100 mm (HCX)

DIA Ø 51 - 100 mm:  
Available on request

# HSS metric

## HSS

### Weldon shank



### Universal shank



### Shank sizes

DIA Ø 12 - 60 mm:  
19.05 mm (3/4")

DIA Ø 61 - 100 mm:  
31.75 mm (1 1/4")



### DoC

Depth of Cut measured inside cutter

	DoC 30 mm Weldon	DoC 30 mm Universal	DoC 55 mm Weldon	DoC 55 mm Universal	DoC 75 mm Weldon	DoC 100 mm Weldon
DIA	Ø 12 - 100 mm	Ø 12 - 60 mm	Ø 12 - 100 mm	Ø 12 - 60 mm	Ø 14 - 50 mm	Ø 18 - 50 mm
	Code	Code	Code	Code	Code	Code
Ø 60	HCS.600	HCSU.600	HCL.600	HCLU.600		
Ø 61	HCS.610		HCL.610			
Ø 62	HCS.620		HCL.620			
Ø 63	HCS.630		HCL.630			
Ø 64	HCS.640		HCL.640			
Ø 65	HCS.650		HCL.650			
Ø 66	HCS.660		HCL.660			
Ø 67	HCS.670		HCL.670			
Ø 68	HCS.680		HCL.680			
Ø 69	HCS.690		HCL.690			
Ø 70	HCS.700		HCL.700			
Ø 71	HCS.710		HCL.710			
Ø 72	HCS.720		HCL.720			
Ø 73	HCS.730		HCL.730			
Ø 74	HCS.740		HCL.740			
Ø 75	HCS.750		HCL.750			
Ø 76	HCS.760		HCL.760			
Ø 77	HCS.770		HCL.770			
Ø 78	HCS.780		HCL.780			
Ø 79	HCS.790		HCL.790			
Ø 80	HCS.800		HCL.800			
Ø 81	HCS.810		HCL.810			
Ø 82	HCS.820		HCL.820			
Ø 83	HCS.830		HCL.830			
Ø 84	HCS.840		HCL.840			
Ø 85	HCS.850		HCL.850			
Ø 86	HCS.860		HCL.860			
Ø 87	HCS.870		HCL.870			
Ø 88	HCS.880		HCL.880			
Ø 89	HCS.890		HCL.890			
Ø 90	HCS.900		HCL.900			
Ø 91	HCS.910		HCL.910			
Ø 92	HCS.920		HCL.920			
Ø 93	HCS.930		HCL.930			
Ø 94	HCS.940		HCL.940			
Ø 95	HCS.950		HCL.950			
Ø 96	HCS.960		HCL.960			
Ø 97	HCS.970		HCL.970			
Ø 98	HCS.980		HCL.980			
Ø 99	HCS.990		HCL.990			
Ø 100	HCS.1000		HCL.1000			

### DoC 75 mm (HCY)

DIA Ø 51 - 100 mm:  
Available on request

### DoC 100 mm (HCX)

DIA Ø 51 - 100 mm:  
Available on request

## 10 piece HSS cutter sets

### DoC 30 mm

- 10 piece annular cutter set
- Cutter sizes Ø 12, 14, 16, 18, 20, 22, 24, 26, 28, 30 mm
- Pilot pin IBC.70 included

HCS.KIT/10

### DoC 30 mm

- 10 piece annular cutter set
- Cutter sizes 3 x Ø 14, 3 x Ø 18, 2 x Ø 22, 2 x Ø 26 mm
- 2 x Pilot pin IBC.70 included

HSS.KIT/10S-M2

### DoC 55 mm

- 10 piece annular cutter set
- Cutter sizes Ø 12, 14, 16, 18, 20, 22, 24, 26, 28, 30 mm
- 2 x Pilot pin IBC.90 included

HCL.KIT/10

### DoC 55 mm

- 10 piece annular cutter set
- Cutter sizes 3 x Ø 14, 3 x Ø 18, 2 x Ø 22, 2 x Ø 26 mm
- 2 x Pilot pin IBC.90 included

HSS.KIT/10L-M2





## Annular cutter

# High Speed Steel Stack



Standard HSS Euroboor annular cutters feature teeth geometry which is optimised for use on single layer workpieces, ensuring the fastest and best drilling performance. The rest material created with the use of these cutters is our signature: the Euroboor slug. The rim on this slug is exactly what prevents our standard HSS cutters from penetrating the second layer of material. In order to drill multiple layers of material simultaneously, we recommend the use of our annular cutters with stack geometry.

The unique teeth profile ensures safe and stable penetration: layer for layer.

Combined with the standard performance improving characteristics of Euroboor annular cutters this results in smooth layer transitions, precise and clean hole finishes and the time savings you are looking for.

HSS stack material application													
Plastics GRP/CRP	Brass, Copper, Tin	Grey cast iron	Steel					Stainless steel		Aluminium		Exotic materials, Inconnell, Nimonic, HARDOX, Hastelloy	Rails
			< 500N	< 750N	< 900N	< 1,100N	< 1,400N	< 900N	≤ 900N	< 10% Si	≤ 10% Si		
●	○		●	●	○					○			

## HSS profile

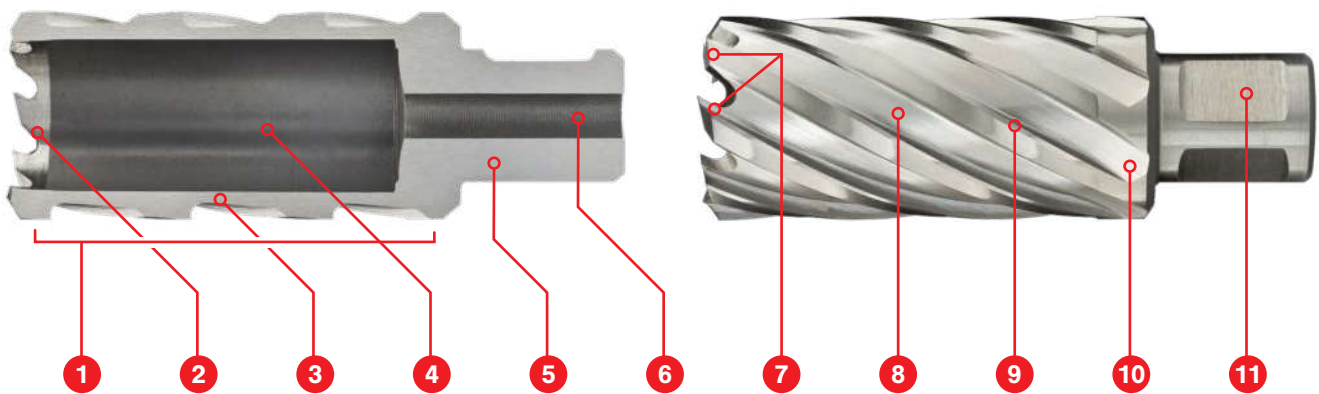

1. Stage hardening. Combines maximum hardness at the teeth with superior strength at the cutter body, reducing breakage to a minimum.
2. Extra deep inner ground cutting teeth. Helps stable "setting" of the cutter, reduces friction during drilling and helps (multiple) slug ejection.
3. Wall thickness matched to the diameter of the cutter, combining the best possible cutting time with strength.
4. Tapered inside fitment prevents the cutter getting stuck. Guaranteed slug(s) ejection with usage of the correct pilot pin.
5. Precise shank fitment for maximum interchangeability and close tolerance drilling without run-out.
6. Precise pilot pin fitment for perfect centration, hassle-free pin retraction and controlled lubricant flow.
7. Stack teeth geometry ensures stable and precise material penetration with fast cutting performance
8. Well-thought-out spiral flute angles for optimal chip removal.
9. Specially designed blades for optimum stability and heat-reduction.
10. Number of flutes and teeth matched to the diameter of the cutter for the best tooth load and superior cutting speeds.
11. Precision ground shanks for optimum fitment of the cutter itself in the tool holder and of pilot pin in the annular cutter. Increases safety, stability and accurate hole dimensions.

# HSS Stack

**Weldon shank**



**Shank sizes**

DIA Ø 18 - 32 mm:  
19.05 mm (3/4")

	DoC 55 mm Weldon	DoC 75 mm Weldon
<b>DIA</b>	<b>Ø 18 - 32 mm</b>	
	<b>Code</b>	<b>Code</b>
Ø 18	HCPL.180	HCPY.180
Ø 19	HCPL.190	HCPY.190
Ø 20	HCPL.200	HCPY.200
Ø 21	HCPL.210	HCPY.210
Ø 22	HCPL.220	HCPY.220
Ø 23	HCPL.230	HCPY.230
Ø 24	HCPL.240	HCPY.240
Ø 25	HCPL.250	HCPY.250
Ø 26	HCPL.260	HCPY.260
Ø 27	HCPL.270	HCPY.270
Ø 28	HCPL.280	HCPY.280
Ø 29	HCPL.290	HCPY.290
Ø 30	HCPL.300	HCPY.300
Ø 31	HCPL.310	HCPY.310
Ø 32	HCPL.320	HCPY.320



**Standard**

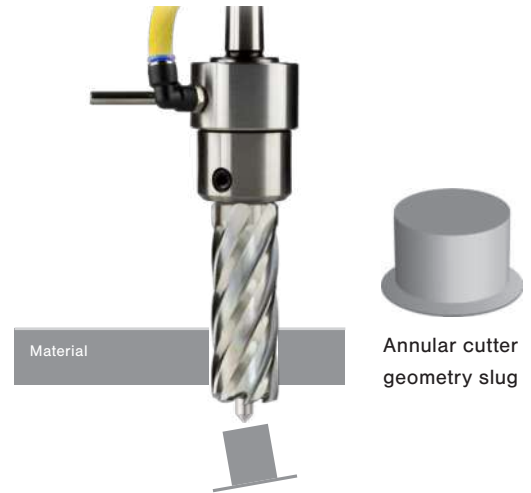

**Stack cutting**

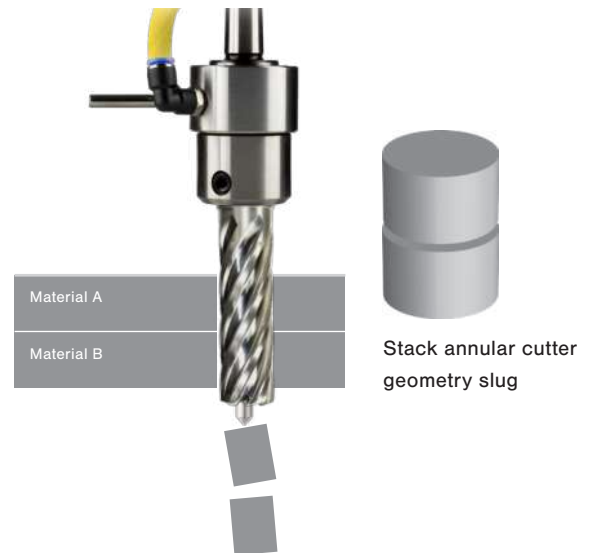

## Annular cutter

# High Speed Steel Cobalt



Euroboor HSS-Cobalt annular cutters are made of Molybdenum-Chromium-Vanadium-Tungsten alloy High Speed Steel with an additional 5% Cobalt (HSS-M35), which results in higher hardness but minimizes the chance of cutter breakage. The HSS-Cobalt annular cutter is specifically designed to remain cool when cutting holes. All flutes are fully ground, resulting in super-fast feed rates and smooth

holes in hard materials, providing better chip clearance and higher cutting performances. The M35 HSS-Cobalt annular cutter is widely used in the metalworking industry for its superior red hardness compared to more conventional high speed steels. This will lead to shorter cycle times in production environments due to higher cutting speeds.

### HSS-Cobalt material application

● Optimal ○ Good ○ Possible

Plastics GRP/CRP	Brass, Copper, Tin	Grey cast iron	Steel					Stainless steel		Aluminium		Exotic materials, Inconnell, Nimonic, HARDOX, Hastelloy	Rails
			< 500N	< 750N	< 900N	< 1,100N	< 1,400N	< 900N	≤ 900N	< 10% Si	≤ 10% Si		
●	●	○	●	●	●	○	○	○	○	●	○	○	

## HSS-Cobalt profile

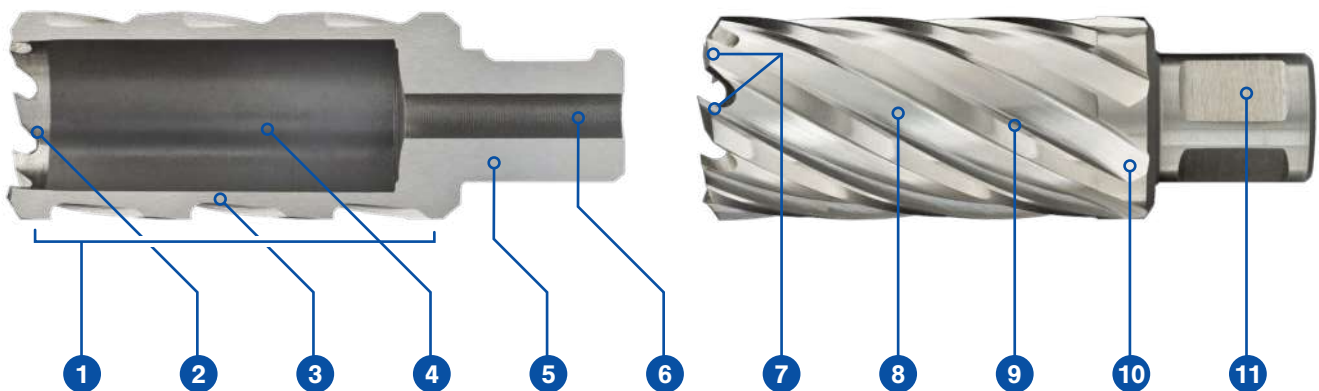

1. Stage hardening. Combines maximum hardness at the teeth with superior strength at the cutter body, reducing breakage to a minimum.
2. Inner ground cutting teeth. Helps stable "setting" of the cutter, reduces friction during and drilling and helps slug ejection.
3. Wall thickness matched to the diameter of the cutter, combining the best possible cutting time with strength.
4. Tapered inside fitment prevents the cutter getting stuck. Guaranteed slug ejection with usage of the correct pilot pin.
5. Precise shank fitment for maximum interchangeability and close tolerance drilling without run-out.
6. Precise pilot pin fitment for perfect centration, hassle-free pin retraction and controlled lubricant flow.
7. Altering "continuous pre-cut" teeth geometry. Generates faster and more stable drilling performance and results in clear cuts of the highest precision and smooth, burr-free finishes.
8. Well-thought-out spiral flute angles for optimal chip removal.
9. Specially designed blades for optimum stability and heat-reduction.
10. Number of flutes and teeth matched to the diameter of the cutter for the best tooth load and superior cutting speeds.
11. Precision ground shanks for optimum fitment of the cutter itself in the tool holder and of pilot pin in the annular cutter. Increases safety, stability and accurate hole dimensions.

# HSS Cobalt

Weldon shank



Shank sizes

DIA Ø 12 - 60 mm:  
19.05 mm (3/4")



	DoC 30 mm Weldon	DoC 55 mm Weldon
<b>DIA</b> Ø 12 - 60 mm		
	Code	Code
Ø 12	IBS.120	IBL.120
Ø 13	IBS.130	IBL.130
Ø 14	IBS.140	IBL.140
Ø 15	IBS.150	IBL.150
Ø 16	IBS.160	IBL.160
Ø 17	IBS.170	IBL.170
Ø 18	IBS.180	IBL.180
Ø 19	IBS.190	IBL.190
Ø 20	IBS.200	IBL.200
Ø 21	IBS.210	IBL.210
Ø 22	IBS.220	IBL.220
Ø 23	IBS.230	IBL.230
Ø 24	IBS.240	IBL.240
Ø 25	IBS.250	IBL.250
Ø 26	IBS.260	IBL.260
Ø 27	IBS.270	IBL.270
Ø 28	IBS.280	IBL.280
Ø 29	IBS.290	IBL.290
Ø 30	IBS.300	IBL.300
Ø 31	IBS.310	IBL.310
Ø 32	IBS.320	IBL.320
Ø 33	IBS.330	IBL.330
Ø 34	IBS.340	IBL.340
Ø 35	IBS.350	IBL.350
Ø 36	IBS.360	IBL.360
Ø 37	IBS.370	IBL.370
Ø 38	IBS.380	IBL.380
Ø 39	IBS.390	IBL.390
Ø 40	IBS.400	IBL.400
Ø 41	IBS.410	IBL.410
Ø 42	IBS.420	IBL.420
Ø 43	IBS.430	IBL.430
Ø 44	IBS.440	IBL.440
Ø 45	IBS.450	IBL.450
Ø 46	IBS.460	IBL.460
Ø 47	IBS.470	IBL.470
Ø 48	IBS.480	IBL.480
Ø 49	IBS.490	IBL.490
Ø 50	IBS.500	IBL.500
Ø 51	IBS.510	IBL.510
Ø 52	IBS.520	IBL.520
Ø 53	IBS.530	IBL.530
Ø 54	IBS.540	IBL.540
Ø 55	IBS.550	IBL.550
Ø 56	IBS.560	IBL.560
Ø 57	IBS.570	IBL.570
Ø 58	IBS.580	IBL.580
Ø 59	IBS.590	IBL.590
Ø 60	IBS.600	IBL.600

## Annular cutter

# Tungsten Carbide Tipped

Euroboor TCT (**SANDVIK**) annular cutters are equipped with a spiral flute which creates optimum chip removal and makes seizure virtually impossible. These annular cutters are used for example in hardened materials such as HARDOX steel, stainless steels and high

tensile strength steel such as railway tracks. Because of the above composition, and when used in a proper way, these cutters are less susceptible to breakage than standard High Speed Steel cutters, especially in larger diameters and lengths.

TCT material application													
Plastics GRP/CRP	Brass, Copper, Tin	Grey cast iron	Steel					Stainless steel		Aluminium		Exotic materials, Inconnell, Nimonic, HARDOX, Hastelloy	Rails
			< 500N	< 750N	< 900N	< 1,100N	< 1,400N	< 900N	≤ 900N	< 10% Si	≤ 10% Si		
	○	●	●	●	●	●	●	●	●	●	●	●	○

## TCT profile

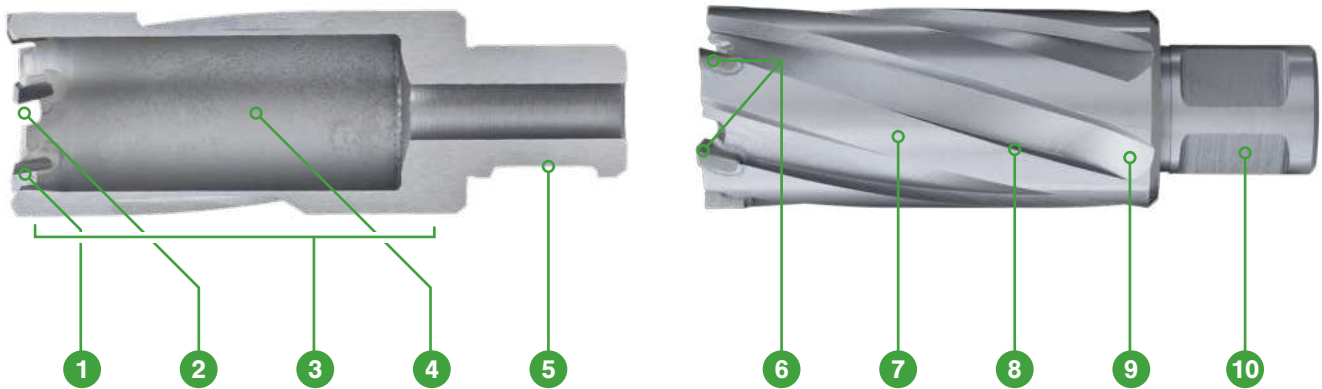

- Extremely hard and durable tungsten carbide cutting teeth (**SANDVIK**) for the hardest of drilling tasks. Offset positioning for the lowest possible heat development.
- Optimised cutting angles for shortest drilling times and clearest cuts.
- Special alloy body for optimum strength and durability.
- Tapered inside fitment prevents the cutter getting stuck. Guaranteed slug ejection with usage of the correct pilot pin.
- Precise shank fitment for maximum interchangeability and close tolerance drilling without run-out.
- Altering "continuous pre-cut" teeth geometry. Generates faster and more stable drilling performance and results in clear cuts of the highest precision and smooth, burr-free finishes. **SANDVIK** carbide tipped.
- Well-thought-out spiral flute angles for optimal chip removal.
- Specially designed blades for optimum stability and heat-reduction.
- Number of flutes and teeth matched to the diameter of the cutter for the best tooth load and superior cutting speeds.
- Precision ground shanks for optimum fitment of the cutter itself in the tool holder and of pilot pin in the annular cutter. Increases safety, stability and accurate hole dimensions.

TCT metric

**TCT**

Weldon shank



WeiNit shank



Shank sizes

DIA Ø 12 - 60 mm:  
19.05 mm (3/4")

DIA Ø 61 - 200 mm:  
31.75 mm (1 1/4")



**DoC**  
Depth of Cut measured inside cutter

	DoC 35 mm Weldon	DoC 35 mm WeiNit	DoC 55 mm Weldon	DoC 55 mm WeiNit
DIA	Ø 12 - 100 mm	Ø 12 - 60 mm	Ø 12 - 200 mm	Ø 12 - 60 mm
	Code	Code	Code	Code
Ø 12	HMS.120	HMSU.120	HML.120	HMLU.120
Ø 13	HMS.130	HMSU.130	HML.130	HMLU.130
Ø 14	HMS.140	HMSU.140	HML.140	HMLU.140
Ø 15	HMS.150	HMSU.150	HML.150	HMLU.150
Ø 16	HMS.160	HMSU.160	HML.160	HMLU.160
Ø 17	HMS.170	HMSU.170	HML.170	HMLU.170
Ø 18	HMS.180	HMSU.180	HML.180	HMLU.180
Ø 19	HMS.190	HMSU.190	HML.190	HMLU.190
Ø 20	HMS.200	HMSU.200	HML.200	HMLU.200
Ø 21	HMS.210	HMSU.210	HML.210	HMLU.210
Ø 22	HMS.220	HMSU.220	HML.220	HMLU.220
Ø 23	HMS.230	HMSU.230	HML.230	HMLU.230
Ø 24	HMS.240	HMSU.240	HML.240	HMLU.240
Ø 25	HMS.250	HMSU.250	HML.250	HMLU.250
Ø 26	HMS.260	HMSU.260	HML.260	HMLU.260
Ø 27	HMS.270	HMSU.270	HML.270	HMLU.270
Ø 28	HMS.280	HMSU.280	HML.280	HMLU.280
Ø 29	HMS.290	HMSU.290	HML.290	HMLU.290
Ø 30	HMS.300	HMSU.300	HML.300	HMLU.300
Ø 31	HMS.310	HMSU.310	HML.310	HMLU.310
Ø 32	HMS.320	HMSU.320	HML.320	HMLU.320
Ø 33	HMS.330	HMSU.330	HML.330	HMLU.330
Ø 34	HMS.340	HMSU.340	HML.340	HMLU.340
Ø 35	HMS.350	HMSU.350	HML.350	HMLU.350
Ø 36	HMS.360	HMSU.360	HML.360	HMLU.360
Ø 37	HMS.370	HMSU.370	HML.370	HMLU.370
Ø 38	HMS.380	HMSU.380	HML.380	HMLU.380
Ø 39	HMS.390	HMSU.390	HML.390	HMLU.390
Ø 40	HMS.400	HMSU.400	HML.400	HMLU.400
Ø 41	HMS.410	HMSU.410	HML.410	HMLU.410
Ø 42	HMS.420	HMSU.420	HML.420	HMLU.420
Ø 43	HMS.430	HMSU.430	HML.430	HMLU.430
Ø 44	HMS.440	HMSU.440	HML.440	HMLU.440
Ø 45	HMS.450	HMSU.450	HML.450	HMLU.450
Ø 46	HMS.460	HMSU.460	HML.460	HMLU.460
Ø 47	HMS.470	HMSU.470	HML.470	HMLU.470
Ø 48	HMS.480	HMSU.480	HML.480	HMLU.480
Ø 49	HMS.490	HMSU.490	HML.490	HMLU.490
Ø 50	HMS.500	HMSU.500	HML.500	HMLU.500
Ø 51	HMS.510	HMSU.510	HML.510	HMLU.510
Ø 52	HMS.520	HMSU.520	HML.520	HMLU.520
Ø 53	HMS.530	HMSU.530	HML.530	HMLU.530
Ø 54	HMS.540	HMSU.540	HML.540	HMLU.540
Ø 55	HMS.550	HMSU.550	HML.550	HMLU.550
Ø 56	HMS.560	HMSU.560	HML.560	HMLU.560
Ø 57	HMS.570	HMSU.570	HML.570	HMLU.570
Ø 58	HMS.580	HMSU.580	HML.580	HMLU.580
Ø 59	HMS.590	HMSU.590	HML.590	HMLU.590
Ø 60	HMS.600	HMSU.600	HML.600	HMLU.600
Ø 61	HMS.610		HML.610	
Ø 62	HMS.620		HML.620	
Ø 63	HMS.630		HML.630	
Ø 64	HMS.640		HML.640	
Ø 65	HMS.650		HML.650	

	DoC 35 mm Weldon	DoC 35 mm WeNit	DoC 55 mm Weldon	DoC 55 mm WeNit
DIA	Ø 12 - 100 mm	Ø 12 - 60 mm	Ø 12 - 200 mm	Ø 12 - 60 mm
	Code	Code	Code	Code
Ø 66	HMS.660		HML.660	
Ø 67	HMS.670		HML.670	
Ø 68	HMS.680		HML.680	
Ø 69	HMS.690		HML.690	
Ø 70	HMS.700		HML.700	
Ø 71	HMS.710		HML.710	
Ø 72	HMS.720		HML.720	
Ø 73	HMS.730		HML.730	
Ø 74	HMS.740		HML.740	
Ø 75	HMS.750		HML.750	
Ø 76	HMS.760		HML.760	
Ø 77	HMS.770		HML.770	
Ø 78	HMS.780		HML.780	
Ø 79	HMS.790		HML.790	
Ø 80	HMS.800		HML.800	
Ø 81	HMS.810		HML.810	
Ø 82	HMS.820		HML.820	
Ø 83	HMS.830		HML.830	
Ø 84	HMS.840		HML.840	
Ø 85	HMS.850		HML.850	
Ø 86	HMS.860		HML.860	
Ø 87	HMS.870		HML.870	
Ø 88	HMS.880		HML.880	
Ø 89	HMS.890		HML.890	
Ø 90	HMS.900		HML.900	
Ø 91	HMS.910		HML.910	
Ø 92	HMS.920		HML.920	
Ø 93	HMS.930		HML.930	
Ø 94	HMS.940		HML.940	
Ø 95	HMS.950		HML.950	
Ø 96	HMS.960		HML.960	
Ø 97	HMS.970		HML.970	
Ø 98	HMS.980		HML.980	
Ø 99	HMS.990		HML.990	
Ø 100	HMS.1000		HML.1000	
Ø 101			HML.1010	
Ø 102			HML.1020	
Ø 103			HML.1030	
Ø 104			HML.1040	
Ø 105			HML.1050	
Ø 106			HML.1060	
Ø 107			HML.1070	
Ø 108			HML.1080	
Ø 109			HML.1090	
Ø 110			HML.1100	
Ø 111			HML.1110	
Ø 112			HML.1120	
Ø 113			HML.1130	
Ø 114			HML.1140	
Ø 115			HML.1150	
Ø 116			HML.1160	
Ø 117			HML.1170	
Ø 118			HML.1180	
Ø 119			HML.1190	

**TCT**

Weldon shank



WeNit shank



Shank sizes

DIA Ø 12 - 60 mm:  
19.05 mm (3/4")

DIA Ø 61 - 200 mm:  
31.75 mm (1 1/4")



# TCT metric

## TCT

### Weldon shank



### WeiNit shank



### Shank sizes

DIA Ø 12 - 60 mm:  
19.05 mm (3/4")

DIA Ø 61 - 200 mm:  
31.75 mm (1 1/4")



**DoC**  
Depth of Cut measured inside cutter

	DoC 35 mm Weldon	DoC 35 mm WeiNit	DoC 55 mm Weldon	DoC 55 mm WeiNit
DIA	Ø 12 - 100 mm	Ø 12 - 60 mm	Ø 12 - 200 mm	Ø 12 - 60 mm
	Code	Code	Code	Code
Ø 120			HML.1200	
Ø 121			HML.1210	
Ø 122			HML.1220	
Ø 123			HML.1230	
Ø 124			HML.1240	
Ø 125			HML.1250	
Ø 126			HML.1260	
Ø 127			HML.1270	
Ø 128			HML.1280	
Ø 129			HML.1290	
Ø 130			HML.1300	
Ø 131			HML.1310	
Ø 132			HML.1320	
Ø 133			HML.1330	
Ø 134			HML.1340	
Ø 135			HML.1350	
Ø 136			HML.1360	
Ø 137			HML.1370	
Ø 138			HML.1380	
Ø 139			HML.1390	
Ø 140			HML.1400	
Ø 141			HML.1410	
Ø 142			HML.1420	
Ø 143			HML.1430	
Ø 144			HML.1440	
Ø 145			HML.1450	
Ø 146			HML.1460	
Ø 147			HML.1470	
Ø 148			HML.1480	
Ø 149			HML.1490	
Ø 150			HML.1500	
Ø 151			HML.1510	
Ø 152			HML.1520	
Ø 153			HML.1530	
Ø 154			HML.1540	
Ø 155			HML.1550	
Ø 156			HML.1560	
Ø 157			HML.1570	
Ø 158			HML.1580	
Ø 159			HML.1590	
Ø 160			HML.1600	
Ø 161			HML.1610	
Ø 162			HML.1620	
Ø 163			HML.1630	
Ø 164			HML.1640	
Ø 165			HML.1650	
Ø 166			HML.1660	
Ø 167			HML.1670	
Ø 168			HML.1680	
Ø 169			HML.1690	
Ø 170			HML.1700	
Ø 171			HML.1710	
Ø 172			HML.1720	
Ø 173			HML.1730	

	DoC 35 mm Weldon	DoC 35 mm WeINit	DoC 55 mm Weldon	DoC 55 mm WeINit
DIA	Ø 12 - 100 mm	Ø 12 - 60 mm	Ø 12 - 200 mm	Ø 12 - 60 mm
	Code	Code	Code	Code
Ø 174			HML.1740	
Ø 175			HML.1750	
Ø 176			HML.1760	
Ø 177			HML.1770	
Ø 178			HML.1780	
Ø 179			HML.1790	
Ø 180			HML.1800	
Ø 181			HML.1810	
Ø 182			HML.1820	
Ø 183			HML.1830	
Ø 184			HML.1840	
Ø 185			HML.1850	
Ø 186			HML.1860	
Ø 187			HML.1870	
Ø 188			HML.1880	
Ø 189			HML.1890	
Ø 190			HML.1900	
Ø 191			HML.1910	
Ø 192			HML.1920	
Ø 193			HML.1930	
Ø 194			HML.1940	
Ø 195			HML.1950	
Ø 196			HML.1960	
Ø 197			HML.1970	
Ø 198			HML.1980	
Ø 199			HML.1990	
Ø 200			HML.2000	



Weldon shank



WeINit shank



Shank sizes

DIA Ø 12 - 60 mm:  
19.05 mm (3/4")

DIA Ø 61 - 200 mm:  
31.75 mm (1 1/4")



**DoC**  
Depth of Cut measured inside cutter

# TCT metric

## TCT

### Weldon shank



### Shank sizes

DIA Ø 12 - 60 mm:  
19.05 mm (3/4")

DIA Ø 61 - 200 mm:  
31.75 mm (1 1/4")



### DoC

Depth of Cut measured inside cutter

	DoC 75 mm Weldon	DoC 100 mm Weldon	DoC 150 mm Weldon	DoC 200 mm Weldon
DIA	Ø 12 - 50 mm	Ø 12 - 200 mm	Ø 22 - 200 mm	Ø 22 - 200 mm
	Code	Code	Code	Code
Ø 12	HMY.120	HMX.120		
Ø 13	HMY.130	HMX.130		
Ø 14	HMY.140	HMX.140		
Ø 15	HMY.150	HMX.150		
Ø 16	HMY.160	HMX.160		
Ø 17	HMY.170	HMX.170		
Ø 18	HMY.180	HMX.180		
Ø 19	HMY.190	HMX.190		
Ø 20	HMY.200	HMX.200		
Ø 21	HMY.210	HMX.210		
Ø 22	HMY.220	HMX.220	HMW.220	HMV.220
Ø 23	HMY.230	HMX.230	HMW.230	HMV.230
Ø 24	HMY.240	HMX.240	HMW.240	HMV.240
Ø 25	HMY.250	HMX.250	HMW.250	HMV.250
Ø 26	HMY.260	HMX.260	HMW.260	HMV.260
Ø 27	HMY.270	HMX.270	HMW.270	HMV.270
Ø 28	HMY.280	HMX.280	HMW.280	HMV.280
Ø 29	HMY.290	HMX.290	HMW.290	HMV.290
Ø 30	HMY.300	HMX.300	HMW.300	HMV.300
Ø 31	HMY.310	HMX.310	HMW.310	HMV.310
Ø 32	HMY.320	HMX.320	HMW.320	HMV.320
Ø 33	HMY.330	HMX.330	HMW.330	HMV.330
Ø 34	HMY.340	HMX.340	HMW.340	HMV.340
Ø 35	HMY.350	HMX.350	HMW.350	HMV.350
Ø 36	HMY.360	HMX.360	HMW.360	HMV.360
Ø 37	HMY.370	HMX.370	HMW.370	HMV.370
Ø 38	HMY.380	HMX.380	HMW.380	HMV.380
Ø 39	HMY.390	HMX.390	HMW.390	HMV.390
Ø 40	HMY.400	HMX.400	HMW.400	HMV.400
Ø 41	HMY.410	HMX.410	HMW.410	HMV.410
Ø 42	HMY.420	HMX.420	HMW.420	HMV.420
Ø 43	HMY.430	HMX.430	HMW.430	HMV.430
Ø 44	HMY.440	HMX.440	HMW.440	HMV.440
Ø 45	HMY.450	HMX.450	HMW.450	HMV.450
Ø 46	HMY.460	HMX.460	HMW.460	HMV.460
Ø 47	HMY.470	HMX.470	HMW.470	HMV.470
Ø 48	HMY.480	HMX.480	HMW.480	HMV.480
Ø 49	HMY.490	HMX.490	HMW.490	HMV.490
Ø 50	HMY.500	HMX.500	HMW.500	HMV.500
Ø 51		HMX.510	HMW.510	HMV.510
Ø 52		HMX.520	HMW.520	HMV.520
Ø 53		HMX.530	HMW.530	HMV.530
Ø 54		HMX.540	HMW.540	HMV.540
Ø 55		HMX.550	HMW.550	HMV.550
Ø 56		HMX.560	HMW.560	HMV.560
Ø 57		HMX.570	HMW.570	HMV.570
Ø 58		HMX.580	HMW.580	HMV.580
Ø 59		HMX.590	HMW.590	HMV.590
Ø 60		HMX.600	HMW.600	HMV.600
Ø 61		HMX.610	HMW.610	HMV.610
Ø 62		HMX.620	HMW.620	HMV.620
Ø 63		HMX.630	HMW.630	HMV.630
Ø 64		HMX.640	HMW.640	HMV.640
Ø 65		HMX.650	HMW.650	HMV.650

	DoC 75 mm Weldon	DoC 100 mm Weldon	DoC 150 mm Weldon	DoC 200 mm Weldon
DIA	Ø 12 - 50 mm	Ø 12 - 200 mm	Ø 22 - 200 mm	Ø 22 - 200 mm
	Code	Code	Code	Code
Ø 66		HMX.660	HMW.660	HMV.660
Ø 67		HMX.670	HMW.670	HMV.670
Ø 68		HMX.680	HMW.680	HMV.680
Ø 69		HMX.690	HMW.690	HMV.690
Ø 70		HMX.700	HMW.700	HMV.700
Ø 71		HMX.710	HMW.710	HMV.710
Ø 72		HMX.720	HMW.720	HMV.720
Ø 73		HMX.730	HMW.730	HMV.730
Ø 74		HMX.740	HMW.740	HMV.740
Ø 75		HMX.750	HMW.750	HMV.750
Ø 76		HMX.760	HMW.760	HMV.760
Ø 77		HMX.770	HMW.770	HMV.770
Ø 78		HMX.780	HMW.780	HMV.780
Ø 79		HMX.790	HMW.790	HMV.790
Ø 80		HMX.800	HMW.800	HMV.800
Ø 81		HMX.810	HMW.810	HMV.810
Ø 82		HMX.820	HMW.820	HMV.820
Ø 83		HMX.830	HMW.830	HMV.830
Ø 84		HMX.840	HMW.840	HMV.840
Ø 85		HMX.850	HMW.850	HMV.850
Ø 86		HMX.860	HMW.860	HMV.860
Ø 87		HMX.870	HMW.870	HMV.870
Ø 88		HMX.880	HMW.880	HMV.880
Ø 89		HMX.890	HMW.890	HMV.890
Ø 90		HMX.900	HMW.900	HMV.900
Ø 91		HMX.910	HMW.910	HMV.910
Ø 92		HMX.920	HMW.920	HMV.920
Ø 93		HMX.930	HMW.930	HMV.930
Ø 94		HMX.940	HMW.940	HMV.940
Ø 95		HMX.950	HMW.950	HMV.950
Ø 96		HMX.960	HMW.960	HMV.960
Ø 97		HMX.970	HMW.970	HMV.970
Ø 98		HMX.980	HMW.980	HMV.980
Ø 99		HMX.990	HMW.990	HMV.990
Ø 100		HMX.1000	HMW.1000	HMV.1000
Ø 101		HMX.1010	HMW.1010	HMV.1010
Ø 102		HMX.1020	HMW.1020	HMV.1020
Ø 103		HMX.1030	HMW.1030	HMV.1030
Ø 104		HMX.1040	HMW.1040	HMV.1040
Ø 105		HMX.1050	HMW.1050	HMV.1050
Ø 106		HMX.1060	HMW.1060	HMV.1060
Ø 107		HMX.1070	HMW.1070	HMV.1070
Ø 108		HMX.1080	HMW.1080	HMV.1080
Ø 109		HMX.1090	HMW.1090	HMV.1090
Ø 110		HMX.1100	HMW.1100	HMV.1100
Ø 111		HMX.1110	HMW.1110	HMV.1110
Ø 112		HMX.1120	HMW.1120	HMV.1120
Ø 113		HMX.1130	HMW.1130	HMV.1130
Ø 114		HMX.1140	HMW.1140	HMV.1140
Ø 115		HMX.1150	HMW.1150	HMV.1150
Ø 116		HMX.1160	HMW.1160	HMV.1160
Ø 117		HMX.1170	HMW.1170	HMV.1170
Ø 118		HMX.1180	HMW.1180	HMV.1180
Ø 119		HMX.1190	HMW.1190	HMV.1190

# TCT

Weldon shank



Shank sizes

DIA Ø 12 - 60 mm:  
19.05 mm (3/4")

DIA Ø 61 - 200 mm:  
31.75 mm (1 1/4")



TCT metric

**TCT**

Weldon shank



Shank sizes

DIA Ø 12 - 60 mm:  
19.05 mm (3/4")

DIA Ø 61 - 200 mm:  
31.75 mm (1 1/4")



**DoC**

Depth of Cut measured inside cutter

	DoC 75 mm Weldon	DoC 100 mm Weldon	DoC 150 mm Weldon	DoC 200 mm Weldon
DIA	Ø 12 - 50 mm	Ø 12 - 200 mm	Ø 22 - 200 mm	Ø 22 - 200 mm
	Code	Code	Code	Code
Ø 120		HMX.1200	HMW.1200	HMV.1200
Ø 121		HMX.1210	HMW.1210	HMV.1210
Ø 122		HMX.1220	HMW.1220	HMV.1220
Ø 123		HMX.1230	HMW.1230	HMV.1230
Ø 124		HMX.1240	HMW.1240	HMV.1240
Ø 125		HMX.1250	HMW.1250	HMV.1250
Ø 126		HMX.1260	HMW.1260	HMV.1260
Ø 127		HMX.1270	HMW.1270	HMV.1270
Ø 128		HMX.1280	HMW.1280	HMV.1280
Ø 129		HMX.1290	HMW.1290	HMV.1290
Ø 130		HMX.1300	HMW.1300	HMV.1300
Ø 131		HMX.1310	HMW.1310	HMV.1310
Ø 132		HMX.1320	HMW.1320	HMV.1320
Ø 133		HMX.1330	HMW.1330	HMV.1330
Ø 134		HMX.1340	HMW.1340	HMV.1340
Ø 135		HMX.1350	HMW.1350	HMV.1350
Ø 136		HMX.1360	HMW.1360	HMV.1360
Ø 137		HMX.1370	HMW.1370	HMV.1370
Ø 138		HMX.1380	HMW.1380	HMV.1380
Ø 139		HMX.1390	HMW.1390	HMV.1390
Ø 140		HMX.1400	HMW.1400	HMV.1400
Ø 141		HMX.1410	HMW.1410	HMV.1410
Ø 142		HMX.1420	HMW.1420	HMV.1420
Ø 143		HMX.1430	HMW.1430	HMV.1430
Ø 144		HMX.1440	HMW.1440	HMV.1440
Ø 145		HMX.1450	HMW.1450	HMV.1450
Ø 146		HMX.1460	HMW.1460	HMV.1460
Ø 147		HMX.1470	HMW.1470	HMV.1470
Ø 148		HMX.1480	HMW.1480	HMV.1480
Ø 149		HMX.1490	HMW.1490	HMV.1490
Ø 150		HMX.1500	HMW.1500	HMV.1500
Ø 151		HMX.1510	HMW.1510	HMV.1510
Ø 152		HMX.1520	HMW.1520	HMV.1520
Ø 153		HMX.1530	HMW.1530	HMV.1530
Ø 154		HMX.1540	HMW.1540	HMV.1540
Ø 155		HMX.1550	HMW.1550	HMV.1550
Ø 156		HMX.1560	HMW.1560	HMV.1560
Ø 157		HMX.1570	HMW.1570	HMV.1570
Ø 158		HMX.1580	HMW.1580	HMV.1580
Ø 159		HMX.1590	HMW.1590	HMV.1590
Ø 160		HMX.1600	HMW.1600	HMV.1600
Ø 161		HMX.1610	HMW.1610	HMV.1610
Ø 162		HMX.1620	HMW.1620	HMV.1620
Ø 163		HMX.1630	HMW.1630	HMV.1630
Ø 164		HMX.1640	HMW.1640	HMV.1640
Ø 165		HMX.1650	HMW.1650	HMV.1650
Ø 166		HMX.1660	HMW.1660	HMV.1660
Ø 167		HMX.1670	HMW.1670	HMV.1670
Ø 168		HMX.1680	HMW.1680	HMV.1680
Ø 169		HMX.1690	HMW.1690	HMV.1690
Ø 170		HMX.1700	HMW.1700	HMV.1700
Ø 171		HMX.1710	HMW.1710	HMV.1710
Ø 172		HMX.1720	HMW.1720	HMV.1720
Ø 173		HMX.1730	HMW.1730	HMV.1730

	DoC 75 mm Weldon	DoC 100 mm Weldon	DoC 150 mm Weldon	DoC 200 mm Weldon
DIA	Ø 12 - 50 mm	Ø 12 - 200 mm	Ø 22 - 200 mm	Ø 22 - 200 mm
	Code	Code	Code	Code
Ø 174		HMX.1740	HMW.1740	HMV.1740
Ø 175		HMX.1750	HMW.1750	HMV.1750
Ø 176		HMX.1760	HMW.1760	HMV.1760
Ø 177		HMX.1770	HMW.1770	HMV.1770
Ø 178		HMX.1780	HMW.1780	HMV.1780
Ø 179		HMX.1790	HMW.1790	HMV.1790
Ø 180		HMX.1800	HMW.1800	HMV.1800
Ø 181		HMX.1810	HMW.1810	HMV.1810
Ø 182		HMX.1820	HMW.1820	HMV.1820
Ø 183		HMX.1830	HMW.1830	HMV.1830
Ø 184		HMX.1840	HMW.1840	HMV.1840
Ø 185		HMX.1850	HMW.1850	HMV.1850
Ø 186		HMX.1860	HMW.1860	HMV.1860
Ø 187		HMX.1870	HMW.1870	HMV.1870
Ø 188		HMX.1880	HMW.1880	HMV.1880
Ø 189		HMX.1890	HMW.1890	HMV.1890
Ø 190		HMX.1900	HMW.1900	HMV.1900
Ø 191		HMX.1910	HMW.1910	HMV.1910
Ø 192		HMX.1920	HMW.1920	HMV.1920
Ø 193		HMX.1930	HMW.1930	HMV.1930
Ø 194		HMX.1940	HMW.1940	HMV.1940
Ø 195		HMX.1950	HMW.1950	HMV.1950
Ø 196		HMX.1960	HMW.1960	HMV.1960
Ø 197		HMX.1970	HMW.1970	HMV.1970
Ø 198		HMX.1980	HMW.1980	HMV.1980
Ø 199		HMX.1990	HMW.1990	HMV.1990
Ø 200		HMX.2000	HMW.2000	HMV.2000

TCT

Weldon shank



Shank sizes

DIA Ø 12 - 60 mm:  
19.05 mm (3/4")

DIA Ø 61 - 200 mm:  
31.75 mm (1 1/4")



## 10 piece TCT cutter sets

### DoC 35 mm

- 10 piece annular cutter set
- Cutter sizes 3 x Ø 14, 3 x Ø 18, 2 x Ø 22, 2 x Ø 26 mm
- Pilot pins IBC.75 & IBC.85 included

**TCT.KIT/10S-M1**

### DoC 55 mm

- 10 piece annular cutter set
- Cutter sizes 3 x Ø 14, 3 x Ø 18, 2 x Ø 22, 2 x Ø 26 mm
- Pilot pins IBC.80 & IBC.90 included

**TCT.KIT/10L-M1**





## Annular cutter

# Tungsten Carbide Tipped Rail



Euroboor TCT Rail cutters are specifically designed to pierce through the toughest rail grades with the greatest of ease. The super micro-grain (**SANDVIK**) tungsten carbide tips contain optimised cutting angles and ensure vigorous and smooth cutting performance. The cutter body is specially engineered to provide maximum stability and

support to cope with the extremely high-torques generated in the cutting process. The design of the specific flutes has been based on keeping a horizontal drilling position and the type of chips from high-tensile strength steel in mind, resulting in optimal chip removal.

TCT Rail material application			● Optimal ○ Good ○ Possible											
Plastics GRP/CRP	Brass, Copper, Tin	Grey cast iron	Steel					Stainless steel		Aluminium		Exotic materials, Inconnell, Nimonic, HARDOX, Hastelloy	Rails	
			< 500N	< 750N	< 900N	< 1,100N	< 1,400N	< 900N	≤ 900N	< 10% Si	≤ 10% Si			
	○	●	●	●	●	●	●	●	●	●	●	●	●	●

Weldon shank



Shank sizes

DIA Ø 12 - 36 mm:

19.05 mm (3/4")



DoC

Depth of Cut measured inside cutter

DIA	DoC 25 mm Weldon	DoC 35 mm * Weldon
	Ø 17 - 36 mm	
	Code	Code
Ø 17	TRCS.170S	TRCS.170
Ø 18	TRCS.180S	TRCS.180
Ø 19	TRCS.190S	TRCS.190
Ø 20	TRCS.200S	TRCS.200
Ø 21	TRCS.210S	TRCS.210
Ø 22	TRCS.220S	TRCS.220
Ø 23	TRCS.230S	TRCS.230
Ø 24	TRCS.240S	TRCS.240
Ø 25	TRCS.250S	TRCS.250
Ø 26	TRCS.260S	TRCS.260
Ø 27	TRCS.270S	TRCS.270
Ø 28	TRCS.280S	TRCS.280
Ø 29	TRCS.290S	TRCS.290
Ø 30	TRCS.300S	TRCS.300
Ø 31	TRCS.310S	TRCS.310
Ø 32	TRCS.320S	TRCS.320
Ø 33	TRCS.330S	TRCS.330
Ø 34	TRCS.340S	TRCS.340
Ø 35	TRCS.350S	TRCS.350
Ø 36	TRCS.360S	TRCS.360

\*availability on request

# ERM.100/3 Resharpener machine



Watch our machines in action on:  
[www.youtube.com/euroboorbv](http://www.youtube.com/euroboorbv)



Technical data	
Dimensions (l x w x h)	480 x 270 x 300 mm
Weight	28 kg
Motor power	250 W
Noise emission	< 70 dBa
Grinding disk	Ø 125 mm
Wheel bore	Ø 25 mm
Shaft bore	19.05 mm Weldon
Speed (no load)	2,800 rpm
Voltage	110 - 120 V / 60 Hz
	220 - 240 V / 50 - 60 Hz

## Benefits

- Resharpens HSS cutters from Ø 12 – 44 mm in cutting depths of 25 – 55 mm
- Easy angle adjustment; simple alignment to original geometry
- Laser guided cutter alignment ensures correct positioning of cutting edge to the wheel
- Motor positioning
- Including CBN\* grinding wheel

\* CBN = Cubic Borid Nitride



Cutter position at the cutter sharpening blade



Motor adjustment

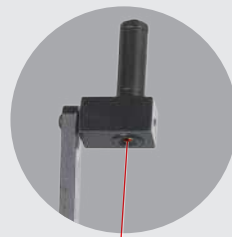

Laser guidance

## Accessory ERM.100/3

**Standard supply**  
 CBN\* Grinding wheel  
 (Resharpener) For HSS

**ERM3.0001**

Index plate T4/T8 & T5/T10

**ERM3.0009**

Index plate T6 & T7

**ERM3.0008**

Index plate T9

**ERM3.0010**

# Pilot pins



**Pilot pins are essential for the use of annular cutters as they control the flow of oil, centrate the cutter and make for a smooth slug ejection.**

Pilot pins are essential for the use of annular cutters, as they provide the following practical uses:

- **Centration of cutter**
- **Control of oil flow**
- **Slug ejection**

As plain as a pilot pin may look, all of these uses require high-precision and extremely low tolerances – just to make sure

the centre is exactly the centre, oil flow starts and stops when you need it to, and the slug does not get stuck inside the cutter.

We offer a wide range of pilot pins that match the lengths, diameters and characteristics of our various annular cutters with exactly the required precision to enhance your drilling job in the best way possible.

**Overview**

Code	Length pin	Diameter pin	Code	Length pin	Diameter pin
IBC.70	77 mm (3")	6.35 mm (1/4")	IBC.K25 <sup>1</sup>	127 mm (5")	6.35 mm (1/4")
IBC.70/2	77 mm (3")	6.35 mm (1/4")	IBC.K50 <sup>1</sup>	155 mm (6 1/8")	6.35 mm (1/4")
IBC.75	90 mm (3 9/16")	6.35 mm (1/4")	IBC.K75 <sup>1</sup>	177 mm (7")	6.35 mm (1/4")
IBC.80	103 mm (4 1/16")	8 mm (5/16")	IBC.K100 <sup>1</sup>	204 mm (8")	6.35 mm (1/4")
IBC.85	90 mm (3 9/16")	8 mm (5/16")	IBC.K110 <sup>1</sup>	159 mm (6 1/4")	6.35 mm (1/4")
IBC.90	102 mm (4")	6.35 mm (1/4")	IBC.2P-130 <sup>2</sup>	130 mm (5 1/8")	8 mm (5/16")
IBC.100	122 mm (4 13/16")	8 mm (5/16")	IBC.2P-144 <sup>2</sup>	145 mm (5 11/16")	8 mm (5/16")
IBC.110	159 mm (6 1/4")	6.35 mm (1/4")	IBC.157 <sup>2</sup>	159 mm (6 1/4")	8 mm (5/16")
IBC.120	120 mm (4 3/4")	6.35 mm (1/4")	IBC.2P-168 <sup>2</sup>	170 mm (6 11/16")	8 mm (5/16")
IBC.130	165 mm (6 1/2")	8 mm (5/16")	IBC.2P-205 <sup>2</sup>	206 mm (8 1/16")	8 mm (5/16")
IBC.140	150 mm (5 15/16")	8 mm (5/16")	IBC.2P-256 <sup>2</sup>	258 mm (10 3/16")	8 mm (5/16")
IBC.150	252 mm (9 15/16")	8 mm (5/16")			
IBC.160	201 mm (7 15/16")	8 mm (5/16")			

For our IBC.70 and IBC.90 pilot pins we also offer sets:

- 3 x IBC.70                      3 x IBC.90
- IBC.70-SET**                      **IBC.90-SET**

**<sup>1</sup> Extended pilot pin**

Specifically for use with long cutters and drilling in very thick workpieces. Makes it possible to continue drilling without mid-process replacement. Suitable for use with longer cutters as from 75 mm (3").

**<sup>2</sup> two-piece pilot pin**



Place pilot pin through the shank, and attach extension through the bottom inside of the cutter.



Start drilling. Stop at approx. 50 mm depth.

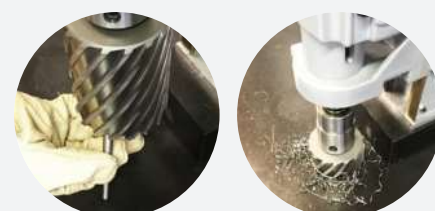

Remove the extension.

Commence drilling until slug ejection.

## Pilot pin features

**Precise positioning**

- Whilst having a perfect fit the Euroboor pilot pin is your guidance to centre the cutter.



Material

**Oil flow regulation**

- In standstill position with the cutter above the workpiece, the pilot pin prevents the oil from flowing.
- When moving down the cutter with the pilot pin onto the workpiece to commence drilling, the pilot pin is pushed up into the arbor and permits the oil to flow into the cutter for direct cooling and lubricating.



Material

**Slug ejection**

- When the cutter is through the material, the pilot pin pushes the slug out of the workpiece by means of the strong spring inside the arbor.
- Consequently the oil flow is automatically cut off.



Material

# Pilot pin recommendations



## HSS metric - 30 mm

HCS (DoC 30 mm)	
Ø 12 - 60 mm IBC.70 (6.35 x 77 mm)	Ø 61 - 100 mm IBC.80 (8.00 x 103 mm)
HCSU (DoC 30 mm)	
Ø 12 - 60 mm IBC.70 (6.35 x 77 mm)	

## HSS metric - 55 mm

HCL (DoC 55 mm)	
Ø 12 - 60 mm IBC.90 (6.35 x 102 mm)	Ø 61 - 100 mm IBC.100 (8.00 x 122 mm) IBC.2P-130 (8.00 x 130 mm)
HCLU (DoC 55 mm)	
Ø 12 - 60 mm IBC.90 (6.35 x 102 mm)	

## HSS metric - 75 & 100 mm

HCY (DoC 75 mm)	HCX (DoC 100 mm)
Ø 14 - 50 mm IBC.K25 (6.35 x 127 mm)	Ø 18 - 50 mm IBC.K50 (6.35 x 155 mm)

## HSS imperial - 1"

HCS (DoC 1")	
Ø 7/16" - 2 5/16" IBC.70 (6.35 x 77 mm)	Ø 2 3/8" - 4" IBC.80 (8.00 x 103 mm)

## HSS imperial - 2"

HCL (DoC 2")	
Ø 7/16" - 2 5/16" IBC.90 (6.35 x 102 mm)	Ø 2 3/8" - 4" IBC.100 (8.00 x 122 mm) IBC.2P-130 (8.00 x 130 mm)
HCLU (DoC 2")	
Ø 7/16" - 2 5/16" IBC.90 (6.35 x 102 mm)	

## HSS Stack metric - 55 & 75 mm

HCPL (DoC 55 mm)	HCPY (DoC 75 mm)
Ø 18 - 32 mm IBC.90 (6.35 x 102 mm)	Ø 18 - 32 mm IBC.K25 (6.35 x 127 mm)

## HSS Stack imperial - 2" & 3"

HCPL (DoC 2")	HCPY (DoC 3")
Ø 11/16" - 1 1/4" IBC.90 (6.35 x 102 mm)	Ø 11/16" - 1 1/4" IBC.K25 (6.35 x 127 mm)

## HSS-Cobalt metric - 30 mm

IBS (DoC 30mm)
Ø 12 - 60 mm IBC.70 (6.35 x 77 mm)

## HSS-Cobalt metric - 55 mm

IBL (DoC 55 mm)
Ø 12 - 60 mm IBC.90 (6.35 x 102 mm)

## HSS-Cobalt imperial - 1"

IBS (DoC 1")
Ø 7/16" - 2 5/16" IBC.70 (6.35 x 77 mm)

## HSS-Cobalt imperial - 2"

IBL (DoC 2")
Ø 7/16" - 2 5/16" IBC.90 (6.35 x 102 mm)

## HSS-Cobalt imperial - 3"

IBY (DoC 3")
Ø 7/16" - 2 5/16" IBC.K25 (6.35 x 127 mm)



## TCT metric - 35 mm

HMS (DoC 35 mm)	
Ø 12 - 17 mm	Ø 18 - 100 mm
IBC.75 (6.35 x 90 mm)	IBC.80 (8.00 x 103 mm)
HMSU (DoC 35 mm)	
Ø 12 - 17 mm	Ø 18 - 60 mm
IBC.75 (6.35 x 90 mm)	IBC.80 (8.00 x 103 mm)

## TCT metric - 55 mm

HML (DoC 55 mm)	
Ø 12 - 17 mm	Ø 61 - 200 mm
IBC.90 (6.35 x 102 mm)	IBC.100 (8.00 x 122 mm)
Ø 18 - 60 mm	IBC.2P-144 (8.00 x 145 mm)
IBC.80 (8.00 x 103 mm)	
HMLU (DoC 55 mm)	
Ø 12 - 17 mm	Ø 18 - 60 mm
IBC.90 (6.35 x 102 mm)	IBC.80 (8.00 x 103 mm)

## TCT metric - 75 &amp; 100 mm

HMV (DoC 75 mm)	HMX (DoC 100 mm)
Ø 12 - 17 mm	Ø 12 - 17 mm
IBC.K25 (6.35 x 127 mm)	IBC.110 (6.35 x 159 mm)
Ø 18 - 50 mm	Ø 18 - 200 mm
IBC.140 (8.00 x 150 mm)	IBC.130 (8.00 x 165 mm)
IBC.157 (8.00 x 159 mm)	IBC.2P-168 (8.00 x 170 mm)

## TCT metric - 150 &amp; 200 mm

HMW (DoC 150 mm)	HMV (DoC 200 mm)
Ø 22 - 200 mm	Ø 22 - 200 mm
IBC.160 (8.00 x 201 mm)	IBC.150 (8.00 x 252 mm)
IBC.2P-205 (8.00 x 206 mm)	IBC.2P-256 (8.00 x 258 mm)

## TCT imperial - 1"

HMS (DoC 1")	
Ø 7/16" - 11/16"	3/4" - 4"
IBC.75 (6.35 x 90 mm)	IBC.80 (8.00 x 103 mm)
HMSU (DoC 1")	
Ø 7/16" - 11/16"	Ø 3/4" - 2 5/16"
IBC.75 (6.35 x 90 mm)	IBC.80 (8.00 x 103 mm)

## TCT imperial - 2"

HML (DoC 2")	
Ø 7/16" - 11/16"	Ø 2 3/8" - 8"
IBC.90 (6.35 x 102 mm)	IBC.100 (8.00 x 122 mm)
3/4" - 2 5/16"	IBC.2P-144 (8.00 x 145 mm)
IBC.80 (8.00 x 103 mm)	
HMLU (DoC 2")	
7/16" - 11/16"	
IBC.90 (6.35 x 102 mm)	
3/4" - 2 15/16"	
IBC.80 (8.00 x 103 mm)	

## TCT imperial - 3" &amp; 4"

HMV (DoC 3")	HMX (DoC 4")
Ø 7/16" - 11/16"	Ø 7/16" - 11/16"
IBC.K25 (6.35 x 127 mm)	IBC.110 (6.35 x 159 mm)
Ø 3/4"- 3"	Ø 3/4" - 8"
IBC.140 (8.00 x 150 mm)	IBC.130 (8.00 x 165 mm)
IBC.157 (8.00 x 159 mm)	IBC.2P-168 (8.00 x 170 mm)

## TCT imperial - 6" &amp; 8"

HMW (DoC 6")	HMV (DoC 8")
Ø 7/8" - 8"	Ø 7/8" - 8"
IBC.160 (8.00 x 201 mm)	IBC.150 (8.00 x 252 mm)
IBC.2P-205 (8.00 x 206 mm)	IBC.2P-256 (8.00 x 258 mm)

## TCT Rail metric - 25 &amp; 35 mm

TRCS (DoC 25 mm)	TRCS (DoC 35 mm)
Ø 17 - 36 mm	Ø 17 - 36 mm
IBC.70 (6.35 x 77 mm)	IBC.75 (6.35 x 90 mm)

## Hole Saw

# Tungsten Carbide Tipped Hole Saw



Twist drills come in different materials and sizes, but above a certain diameter size it's no longer possible to drill with the twist drill. The amount of material to be cut would be too large and the drilling process would take extremely long. That's where the hole saws come in! With our multi-purpose TCT Hole saws you can drill holes from 11 mm up to 50 mm with portable power tools and stationary machines, without using extreme force or power. As the name suggests, the hole saw is hollow in the middle and only the cutting edges cut the material. This saves a lot of time and energy. The great thing about our hole saws is that they are very durable because they are Tungsten carbide tipped. Compared to bimetal hole saws they have a 10 times longer lifespan.

The hole saws are equipped with a pilot drill and ejector spring. The pilot drill allows simple centering and clean guidance in the material. With the ejector spring, the cut material is easily ejected from the hole saw. The safety stopper protects the workpiece (also a hex key is included for fixing the pilot drill).

- Material thickness for hand drills: max. 6 mm (1/4")
- Recommended hole diameter for hand drills: max 25 mm (1")
- Material thickness for portable magnetic drilling machines: max. 27 mm (1 1/16")
- Parallel shank with 3 flats - Fits all common drill chucks

Diameter	Code
11	THS.110
12	THS.120
13	THS.130
14	THS.140
15	THS.150
16	THS.160
17	THS.170
18	THS.180
19	THS.190
20	THS.200
21	THS.210
22	THS.220
23	THS.230
24	THS.240
25	THS.250
26	THS.260
27	THS.270
28	THS.280
29	THS.290
30	THS.300
31	THS.310
32	THS.320

Diameter	Code
33	THS.330
34	THS.340
35	THS.350
36	THS.360
37	THS.370
38	THS.380
39	THS.390
40	THS.400
41	THS.410
42	THS.420
43	THS.430
44	THS.440
45	THS.450
46	THS.460
47	THS.470
48	THS.480
49	THS.490
50	THS.500
7/16"	THS.7/16"
1/2"	THS.1/2"
9/16"	THS.9/16"
5/8"	THS.5/8"

Diameter	Code
11/16"	THS.11/16"
3/4"	THS.3/4"
13/16"	THS.13/16"
7/8"	THS.7/8"
15/16"	THS.15/16"
1"	THS.1"
1-1/16"	THS.1-1/16"
1-1/8"	THS.1-1/8"
1-3/16"	THS.1-3/16"
1-1/4"	THS.1-1/4"
1-5/16"	THS.1-5/16"
1-3/8"	THS.1-3/8"
1-7/16"	THS.1-7/16"
1-1/2"	THS.1-1/2"
1-9/16"	THS.1-9/16"
1-5/8"	THS.1-5/8"
1-11/16"	THS.1-11/16"
1-3/4"	THS.1-3/4"
1-13/16"	THS.1-13/16"
1-7/8"	THS.1-7/8"
1-15/16"	THS.1-15/16"
2"	THS.2"

### Benefits of the TCT hole saw

- Fits in your standard drilling machine
- "Tapered point" twist drill
- 3 mm optimized wall thickness
- 13 mm 3-flat shank
- 27 mm Depth of Cut
- More cutting teeth



Watch our machines in action on:  
[www.youtube.com/euroboorby](http://www.youtube.com/euroboorby)



### 6 piece TCT hole saw kit

- TCT Hole Saw size Ø 12, 14, 16, 18, 20, 22 mm
- HSS-M2 twist drill x6
- Springs x6
- Hex key

**THS.KIT/6-M**

### Specifications

Max. material thickness for drilling in:

- Steel with bench drill: approximately 20 mm (13/16")
- Stainless steel with bench drill: approximately 10 mm (3/8")
- Aluminium with bench drill: approximately 20 mm (13/16")

### TCT Hole Saw

- up to Ø 18 mm (11/16"): 10 mm (3/8") shank
- From Ø 19 mm (3/4") and up: 13 mm (1/2") shank
- Max. depth of cut: 27 mm (1 1/16")
- Wall thickness: 3 mm (1/8")

## Weldon twist drills

HSS 19.05 mm (3/4") Weldon shank. 135° split point. Available in 30 mm, 50 mm length, 1" and 2" (DoC).

**Machined from one solid blank** (no weak spots caused by inferior material or welds).

DoC 30 mm  
DIA Ø 6 - 14 mm

MM	Code
Ø 6	SSPI.06
Ø 7	SSPI.07
Ø 8	SSPI.08
Ø 9	SSPI.09
Ø 10	SSPI.10
Ø 11	SSPI.11
Ø 12	SSPI.12
Ø 13	SSPI.13
Ø 14	SSPI.14

DoC 1"  
DIA Ø 1/4" - 9/16"

INCH	Code
Ø 1/4"	SSPI.1/4"
Ø 5/16"	SSPI.5/16"
Ø 3/8"	SSPI.3/8"
Ø 7/16"	SSPI.7/16"
Ø 1/2"	SSPI.1/2"
Ø 9/16"	SSPI.9/16"



DoC 50 mm  
DIA Ø 6 - 14 mm

MM	Code
Ø 6	SPI.06
Ø 7	SPI.07
Ø 8	SPI.08
Ø 9	SPI.09
Ø 10	SPI.10
Ø 11	SPI.11
Ø 12	SPI.12
Ø 13	SPI.13
Ø 14	SPI.14

DoC 2"  
DIA Ø 1/4" - 9/16"

INCH	Code
Ø 1/4"	SPI.1/4"
Ø 5/16"	SPI.5/16"
Ø 3/8"	SPI.3/8"
Ø 7/16"	SPI.7/16"
Ø 1/2"	SPI.1/2"
Ø 9/16"	SPI.9/16"



## Countersinks

- HSS 19.05 mm (3/4") Weldon shank
- 3 cutting edges
- 90°

**Weldon countersinks**

MM	Code
Ø 10 - 25	SCE.25
Ø 10 - 40	SCE.40
Ø 15 - 50	SCE.50



**Straight shank countersinks**

MM	Code
Ø 6.3	CSB.63
Ø 8.3	CSB.83
Ø 10.4	CSB.104
Ø 12.4	CSB.124
Ø 16.5	CSB.165
Ø 20.5	CSB.205

**6 piece straight shank countersink set**

- Sizes Ø 6.3 - 8.3 - 10.4 - 12.4 - 16.5 - 20.5 mm
- HSS-Cobalt (M35 quality) straight shank
- Compatible with every drill chuck
- 3 cutting edges
- 90°

**CBS.620**



Twist drills



Watch our machines in action on:  
[www.youtube.com/euroboorbv](http://www.youtube.com/euroboorbv)



- HSS-Cobalt (M35 quality)
- 135° split point
- Compatible with every drill chuck

DIA Ø 1 - 13 mm

MM	Code	MM	Code
Ø 1.0	TDCO.010	Ø 7.0	TDCO.070
Ø 1.5	TDCO.015	Ø 7.5	TDCO.075
Ø 2.0	TDCO.020	Ø 8.0	TDCO.080
Ø 2.5	TDCO.025	Ø 8.5	TDCO.085
Ø 3.0	TDCO.030	Ø 9.0	TDCO.090
Ø 3.3	TDCO.033	Ø 9.5	TDCO.095
Ø 3.5	TDCO.035	Ø 10.0	TDCO.100
Ø 4.0	TDCO.040	Ø 10.2	TDCO.102
Ø 4.2	TDCO.042	Ø 10.5	TDCO.105
Ø 4.5	TDCO.045	Ø 11.0	TDCO.110
Ø 5.0	TDCO.050	Ø 11.5	TDCO.115
Ø 5.5	TDCO.055	Ø 12.0	TDCO.120
Ø 6.0	TDCO.060	Ø 12.5	TDCO.125
Ø 6.5	TDCO.065	Ø 13.0	TDCO.130
Ø 6.8	TDCO.068		

Sizes Ø 1.0 - 7.5 mm come pre-packed in hanger box sets of 10 pcs. Sizes Ø 8.0 - 13.0 mm are pre-packed in hanger box sets of 5 pcs. Also available as 19-piece (TDS.100) and 25-piece (TDS.200) set.



25 piece Drill Bit set

- Sizes Ø 1-13 mm with 0,5 mm increments. 3-flats shank (4 mm and up)
- HSS-G (Fully Ground)
- Fully ground, not roll-forged, for more stability
- DIN 338
- 118° split point
- Compatible with every drill chuck
- Drills also sold per 5 or 10 pieces

**TDH.25**

25 piece Drill Bit set

- Sizes Ø 1-13 mm with 0,5 mm increments. 3-flats shank (4mm and up)
- HSS-Co - Steel-cobalt alloy (M35)
- Fully ground, not roll-forged, for more stability
- DIN 338
- 135° split point
- Compatible with almost every drill chuck
- Drills also sold per 5 or 10 pieces

**TDC.25**



19 piece twist drill set

- Sizes Ø 1 - 10 mm, 0.5 mm increments
- HSS-Cobalt (M35 quality)
- DIN 338
- 135° split point
- Compatible with every drill chuck
- Drills also sold per 5 and 10 pieces

**TDS.100**



25 piece twist drill set

- Sizes Ø 1 - 13 mm, 0.5 mm increments
- HSS-Cobalt (M35 quality)
- DIN 338
- 135° split point
- Compatible with every drill chuck
- Drills also sold per 5 and 10 pieces

**TDS.200**

Step drills

- HSS TiN coated
- Spiral flute for efficient chip removal

Step drills

MM	Code
Ø 4 - 12	ESD.412
Ø 4 - 20	ESD.420
Ø 6 - 30	ESD.630



3-piece step drill set

- Sizes:
  - Ø 4 - 12 mm
  - Ø 4 - 20 mm
  - Ø 6 - 30 mm
- HSS TiN coated
- Spiral flute for efficient chip removal

**ESS.430/2**

After drilling aid

Magnetic stick for cleaning up metal shavings.

Ø 22 x 400 mm

Simply wave the magnetic stick over the metal shavings to pick them up, carry them over to your scrap barrel, pull the plunger and the shavings are neatly deposited. The Euroboor magic stick is strong enough to quickly clean up your biggest mess of metal shavings.

- Clean up sharp-edged metal chips, screws and other metal parts easily
- Items are safely ejected off of magic stick without hand contact
- Ideal for hard-to-reach spaces

**MAGICSTICK**



## Tapping chucks



Watch our machines in action on:  
[www.youtube.com/euroboorbv](http://www.youtube.com/euroboorbv)



### Morse Taper torque controlled tapping chucks

Specifically designed for use in combination with portable magnetic drilling machines.

#### Benefits

- + Quick and precise installation of taps
- + Increased operation accuracy
- + Drastically reduced risk of broken taps and destroyed threads

#### Features

- Slip clutch torque limiter
- Clear torque controller adjustment scale
- Full instruction manual including:
  - Installation and mounting guide
  - Torque setting guide
  - Tapping speed guide
  - m/min (ft/min) to rpm calculation
  - Cutting fluid recommendation
  - Maintenance guide
- Full "all parts" servicing possibility
- Complete delivery including:
  - 2 different rubber centration collets
  - All tools required for installation and adjustment



ETC.2



ETC.3



#### Torque controlled tapping chuck MT3

- Machine tap sizes M8 up to M20 (DIN 371 and DIN376)
- Machine tap sizes M14 up to M30 (DIN376)

ETC.2

ETC.3



#### Tapping chuck B16 MT2 - 3

- Quick change M5 - M12
- Including rubber clamps
  - GSW.172121 (Ø 4 - 7 mm)
  - GSW.172122 (Ø 7 - 10 mm)
- Auto reverse

GSW.512R

#### Tapping chuck B22 MT3 - 4

- Quick change M8 - M20
- Including rubber clamps
  - GSW.172202 (Ø 10.38 - 14 mm)
  - GSW.172203 (Ø 16 mm)
- Auto reverse

GSW.820R

### Feature overview

	Morse Taper	Tap capacity	Slip clutch	Automatic reverse
ETC.2	MT3	M8 - M20	•	-
ETC.3	MT3	M14 - M30	•	-
GSW.512R	B16 MT2 / 3	M5 - M12	-	•
GSW.820R	B22 MT3 / 4	M8 - M20	-	•

## Tap holders (Weldon)

All our tap holders are fitted with 3/4" Weldon shank

### DIN 376

Tap holder	Shank	Code
M8	Ø 6 mm	TCM.08D376
M10	Ø 7 mm	TCM.10D376
M12	Ø 9 mm	TCM.12D376
M14	Ø 11 mm	TCM.14D376
M16	Ø 12 mm	TCM.16D376
M18	Ø 14 mm	TCM.18D376
M20	Ø 16 mm	TCM.20D376
M22 - 24	Ø 18 mm	TCM.22D376
M27	Ø 20 mm	TCM.27D376
M30	Ø 22 mm	TCM.30D376

### ISO 529

Tap holder	Shank	Code
M8	Ø 8 mm	TCM.08I529
M10	Ø 10 mm	TCM.10I529
M12	Ø 9 mm	TCM.12I529
M14	Ø 11.2 mm	TCM.14I529
M16	Ø 12.5 mm	TCM.16I529
M18	Ø 14 mm	TCM.18I529
M20	Ø 14 mm	TCM.20I529
M22	Ø 16 mm	TCM.22I529
M24	Ø 18 mm	TCM.24I529
M27 - 30	Ø 20 mm	TCM.27D376

### ASA

Tap holder	Shank	Code
1/4"	Ø 6.5 mm	TCM.1/4"ASA
5/16"	Ø 8.07 mm	TCM.5/16"ASA
3/8"	Ø 9.68 mm	TCM.3/8"ASA
7/16"	Ø 8.2 mm	TCM.7/16"ASA
1/2"	Ø 9.29 mm	TCM.1/2"ASA
9/16"	Ø 10.9 mm	TCM.9/16"ASA
5/8"	Ø 12.17 mm	TCM.5/8"ASA
11/16"	Ø 13.77 mm	TCM.11/16"ASA
3/4"	Ø 14.9 mm	TCM.3/4"ASA
13/16"	Ø 16.5 mm	TCM.13/16"ASA
15/16"	Ø 19.2 mm	TCM.15/16"ASA
1"	Ø 20.2 mm	TCM.1"ASA
1 1/16"	Ø 22.5 mm	TCM.1-1/16"ASA
1 1/8"	Ø 22.7 mm	TCM.1-1/8"ASA
1 3/16"	Ø 25.7 mm	TCM.1-3/16"ASA

### JIS

Tap holder	Shank	Code
M12	Ø 8.5 mm	TCM.12JIS
M14	Ø 10.5 mm	TCM.14JIS
M16	Ø 12.5 mm	TCM.16I529



## Machine taps

Euroboor machine taps are high-precision tools produced according to DIN standard (DIN 371/376) from Cobalt reinforced High Speed Steel (M35 quality).

### Green ring

- Blank finish
- For use in materials such as construction steel, aluminium, zinc, lead, copper and brass

### White ring

- Black oxide finish for improved durability
- For use in materials such as cast iron and stainless steel



### Through holes

Green ring	Size	Specification	Ø	White ring
910.030C	M3 x 0.5	DIN 371	3.5 mm	910.030V
910.040C	M4 x 0.7	DIN 371	4.5 mm	910.040V
910.050C	M5 x 0.8	DIN 371	6 mm	910.050V
910.060C	M6 x 1.0	DIN 371	6 mm	910.060V
910.080C	M8 x 1.25	DIN 371	8 mm	910.080V
910.100C	M10 x 1.5	DIN 371	10 mm	910.100V
900.100C	M10 x 1.5	DIN 376	7 mm	900.100V
900.120C	M12 x 1.75	DIN 376	9 mm	900.120V
900.140C	M14 x 2.0	DIN 376	11 mm	900.140V
900.160C	M16 x 2.0	DIN 376	12 mm	900.160V
900.180C	M18 x 2.5	DIN 376	14 mm	900.180V
900.200C	M20 x 2.5	DIN 376	16 mm	900.200V
900.220C	M22 x 2.5	DIN 376	18 mm	900.220V
900.240C	M24 x 3.0	DIN 376	18 mm	900.240V
900.270C	M27 x 3.0	DIN 376	20 mm	900.270V
900.300C	M30 x 3.5	DIN 376	22 mm	900.300V

We offer the following application choices:

### Through holes

- Straight flute

### Blind holes

- Spiral flute

Green ring White ring



Green ring White ring



### Blind holes

Green ring	Size	Specification	Ø	White ring
910.031C	M3 x 0.5	DIN 371	3.5 mm	910.031V
910.041C	M4 x 0.7	DIN 371	4.5 mm	910.041V
910.051C	M5 x 0.8	DIN 371	6 mm	910.051V
910.061C	M6 x 1.0	DIN 371	6 mm	910.061V
910.081C	M8 x 1.25	DIN 371	8 mm	910.081V
910.101C	M10 x 1.5	DIN 371	10 mm	910.101V
900.101C	M10 x 1.5	DIN 376	7 mm	900.101V
900.121C	M12 x 1.75	DIN 376	9 mm	900.121V
900.141C	M14 x 2.0	DIN 376	11 mm	900.141V
900.161C	M16 x 2.0	DIN 376	12 mm	900.161V
900.181C	M18 x 2.5	DIN 376	14 mm	900.181V
900.201C	M20 x 2.5	DIN 376	16 mm	900.201V
900.221C	M22 x 2.5	DIN 376	18 mm	900.221V
900.241C	M24 x 3.0	DIN 376	18 mm	900.241V
900.271C	M27 x 3.0	DIN 376	20 mm	900.271V
900.301C	M30 x 3.5	DIN 376	22 mm	900.301V

## Tap and twist drill set

### 14 piece twist drill and tap set

- HSS-Cobalt (M35 quality)
- DIN 371/376
- Through holes: straight flute
- White ring: black oxide finish for improved durability.  
For use in materials such as cast iron and stainless steel
- Twist drills (TDCO-series) also sold per 5 and 10 pieces and taps also available separately

**DTS.312**

Twist drills	Taps
Ø 2.5 mm	M3
Ø 3.3 mm	M4
Ø 4.2 mm	M5
Ø 5 mm	M6
Ø 6.8 mm	M8
Ø 8.5 mm	M10
Ø 10.2 mm	M12



## Drill tap combination (sets)

### Features

- Drilling & tapping with 1 tool
- Also suitable for hard metals (such as stainless steel)
- Cost saver:
  - No need for drill chuck adapter
  - No need for drill chuck
  - No need for tap holder
- Time saver:
  - No need finding the correct tool
  - No need to interchange tools
  - No need to reposition drilling machine
- Especially suitable for on-the-job tasks with limitations to the amount of tools you can bring along.
- HSS-Cobalt (M35 quality)
- Black oxide coating



### Application

- Alloy steels, castings & forgings
- Suitable and directly fitting (19.05 mm Weldon connection) to Euroboor magnetic drilling machines:
  - ECO.50-T,
  - ECO.50<sup>+</sup>/T,
  - ECO.55S/T,
  - ECO.55S<sup>+</sup>/T,
  - ECO.55S<sup>+</sup>/TA,
  - ECO.100/4 (D),
  - ECO.100S<sup>+</sup>/T,
  - ECO.100S<sup>+</sup>/TD,
  - TUBE.55S/T
  - TUBE.55S<sup>+</sup>/T

Part number	Tap size	Max. drilling/ tapping depth
EDT.08	M8 x 1.25	17 mm
EDT.10	M10 x 1.5	20 mm
EDT.12	M12 x 1.75	20 mm
EDT.14	M14 x 2.0	18 mm
EDT.16	M16 x 2.0	18 mm
EDT.18	M18 x 2.5	20 mm
EDT.20	M20 x 2.5	25 mm
EDT.22	M22 x 2.5	24 mm
EDT.24	M24 x 3.0	26 mm
EDT.27	M27 x 3.0	29 mm
EDT.30	M30 x 3.5	31 mm

### Drill tap combination sets

- Delivered in luxury case
- Content: EDT.08, EDT.10 and EDT.12

**EDT.SET/1**

- Delivered in luxury case
- Content: EDT.14, EDT.16 and EDT.18

**EDT.SET/2**

# Sets

With the developing of our innovative tools, we focus on adding value and making your daily work easier. Our sets are a good example of this. We offer a wide range of sets for annular cutting, twist drilling, tapping and many more.





### 25 piece Drill Bit set

- Sizes Ø 1-13 mm with 0,5 mm increments. 3-flats shank (4 mm and up)
- HSS-G (Fully Ground)
- Fully ground, not roll-forged, for more stability
- DIN 338
- 118° split point
- Compatible with every drill chuck
- Drills also sold per 5 or 10 pieces

**TDH.25**



### 25 piece Drill Bit set

- Sizes Ø 1-13 mm with 0,5 mm increments. 3-flats shank (4mm and up)
- HSS-Co – Steel-cobalt alloy (M35)
- Fully ground, not roll-forged, for more stability
- DIN 338
- 135° split point
- Compatible with almost every drill chuck
- Drills also sold per 5 or 10 pieces

**TDC.25**



### 19 piece twist drill set

- Sizes Ø 1 - 10 mm, 0.5 mm increments
- HSS-Cobalt (M35 quality)
- DIN 338
- 135° split point
- Compatible with every drill chuck
- Drills also sold per 5 and 10 pieces

**TDS.100**



### 25 piece twist drill set

- Sizes Ø 1 - 13 mm, 0.5 mm increments
- HSS-Cobalt (M35 quality)
- DIN 338
- 135° split point
- Compatible with every drill chuck
- Drills also sold per 5 and 10 pieces

**TDS.200**



### 5 piece rotary burrs set shaft Ø 6 mm

- High-quality Tungsten Carbide (K20).
- Double cut - designed for rapid stock removal.
- Delivered with:
  - RB.A1006 - Cylinder without end cut
  - RB.B1006 - Cylinder with end cut
  - RB.C1206 - Cylinder ball nose
  - RB.F1006 - Cylinder ball nose tree
  - RB.L1206 - Cylinder ball nose cone

**RBS.105**



### 10 piece rotary burrs set shaft Ø 6 mm

- High-quality Tungsten Carbide (K20).
- Double cut - designed for rapid stock removal.
- Delivered with:
  - RB.A1006 - Cylinder without end cut
  - RB.C1006 - Cylinder ball nose
  - RB.D1006 - Cylinder ball
  - RB.E1206 - Cylinder oval
  - RB.F1206 - Cylinder ball nose tree
  - RB.G1206 - Cylinder arc pointed tree
  - RB.J1006 - Cylinder 60 degree cone
  - RB.L1206 - Cylinder ball nose cone
  - RB.M1206 - Cylinder cone
  - RB.N1006 - Cylinder inverted cone

**RBS.110**



### 3-piece step drill set

- Sizes:
  - Ø 4 - 12 mm
  - Ø 4 - 20 mm
  - Ø 6 - 30 mm
- HSS TiN coated
- Spiral flute for efficient chip removal

**ESS.430/2**



### 6 piece straight shank countersink set

- Sizes Ø 6.3 - 8.3 - 10.4 - 12.4 - 16.5 - 20.5 mm
- HSS-Cobalt (M35 quality) straight shank
- Compatible with every drill chuck
- 3 cutting edges
- 90°

**CBS.620**



### 14 piece twist drill and tap set

- HSS-Cobalt (M35 quality)
- DIN 371/376
- Through holes: straight flute
- White ring: black oxide finish for improved durability.
- For use in materials such as cast iron and stainless steel
- Twist drills (TDCO-series) also sold per 5 and 10 pieces and taps also available separately

**DTS.312**



### Drill tap combination sets

- Delivered in luxury case
- Content: EDT.08, EDT.10 and EDT.12

**EDT.SET/1**

- Delivered in luxury case
- Content: EDT.14, EDT.16 and EDT.18

**EDT.SET/2**

# B60 Bevelling machine



Watch our machines in action on:  
[www.youtube.com/euroboorby](http://www.youtube.com/euroboorby)



## Technical data

Spindle speed	2,850 rpm
Max. bevel width	24 mm (45° angle)
Bevel angle	0° - 60°
Pipe diameter	> 150 mm
Length	415 mm
Width	375 mm
Height	268 mm
Weight	24.1 kg
Motor power	1,100 W
Voltage	110 - 120 V / 60 Hz
	220 - 240 V / 50 - 60 Hz



## Benefits

- Powerful high-efficiency motor
- Smooth control with clear, precise and simple (protected) control buttons
- Suitable for pipe material > Ø 150 mm
- Simple replacement and indexation of the cutting plates
- Wide and soft handles

## Features



Adjustment  
angle 0 - 60°



Bevel width  
0 - 24 mm

## Accessories B60



Milling head

**B60.0027**



Carbide cutting plates

(Sold per 10 pieces)

**LKS.15**



Magnetic digital level box

For measuring angles up to 90°

**MLB.90**

# B60S Bevelling machine



Watch our machines in action on:  
[www.youtube.com/euroboorby](http://www.youtube.com/euroboorby)



## Technical data

Spindle speed	1,675 - 2,850 rpm
Max. bevel width	24 mm (45° angle)
Bevel angle	0° - 60°
Pipe diameter	> 150 mm
Length	415 mm
Width	375 mm
Height	268 mm
Weight	24.1 kg
Motor power	1,800 W
Voltage	110 - 120 V / 60 Hz
	220 - 240 V / 50 - 60 Hz



## Benefits

- Powerful high-efficiency motor
- Smooth control with clear, precise and simple (protected) control buttons
- Suitable for pipe material > Ø 150 mm
- Simple replacement and indexation of the cutting plates
- Wide and soft handles
- Exceptional powerful motor (1.800 W)
- Extremely suitable for stainless steel (with the use of stainless steel guide plate)
- Overload protection

## Features



Adjustable speed



Adjustment angle 0 - 60°



Bevel width 0 - 24 mm

## Accessories B60S



**Stainless steel plate**  
To use on stainless steel materials.

**B60.1020S**



**Milling head**  
**B60.0027**



**Carbide cutting plates**  
(Sold per 10 pieces)

**LKS.15**



**Magnetic digital level box**  
For measuring angles up to 90°

**MLB.90**

# B45S Bevelling machine



Watch our machines in action on:  
[www.youtube.com/euroboorby](http://www.youtube.com/euroboorby)



### Technical data

Spindle speed	1,750 - 5,250 rpm
Max. bevel width	6 mm (45° angle)
Min. diameter for inside bevels	20 mm
Spindle thread	M12 x 1.75
Length	458 mm
Width	137 mm
Height	300 mm
Weight	4.4 kg
Motor power	1,250 W
Voltage	110 - 120 V / 60 Hz
	220 - 240 V / 50 - 60 Hz

### Benefits

- Ergonomic main handle, user-friendly controls, spindle speed adjustment range for various materials
- Quick and easy bevel width adjustment
- Clear bevel width indication
- Precision 45° milling head with 3 cutting edges (incl. cutting plates)
- Soft-grip front handle suitable for left- and right-handed users
- Electronic speed stabilization
- Anti-kickback and -breakthrough torque control (slow start)
- Quick and easy carbon brush replacement

### Features



**Adjustable speed**



**Overheat protection**



**Bevel width 0 - 6 mm**



### Accessories B45S



Carbide cutting plates  
 Angle 30° & 45° (Sold per 10 pieces)

**LKS.20**



Carbide cutting plates  
 R2.5 (Sold per 10 pieces)

**LKS.20-R**



### Milling head

Angle 30°

**B45S.1011A**



Angle 45°

**B45S.1011**



R2.5

**B45S.1011B**



### Magnetic digital level box

For measuring angles up to 90°

**MLB.90**

# BM45AIR Mini Air Bevelling machine



Watch our machines in action on:  
[www.youtube.com/euroboorby](http://www.youtube.com/euroboorby)



## Technical data

Spindle speed	28,000 rpm
Max. bevel width	2 mm (45° angle)
Length	150 mm
Height	45 mm
Weight	320 g
Air inlet	Ø 6.35 mm
Air hose	Ø 9.525 mm
Connector type	Euro type 1/4"
Avg. air consumption	0.15 m³/min (5 SCFM)
Working pressure	6 - 8 bar (90 -115 psi)



## Benefits

- Compact and great ergonomic design
- Lightweight machine
- Including 2x 45° and 2x R1.5 cutting plates
- Safety lever trigger to prevent accidental starts
- Bevel depth indicator for precise adjustment of the bevel size
- 6-speed air speed regulator

## Features



**Working pressure**  
 6 - 8 bar  
 (90 - 115 PSI)

## Accessories BM45AIR



Cutting plate for steel. Angle 45°. (Sold per 10 pieces)

**BM45AIR.45ST**



Cutting plate radius 1.5 for steel. Angle 45°. (Sold per 10 pieces)

**BM45AIR.R1.5**



Cutting plate for stainless steel. Angle 45°. (Sold per 10 pieces)

**BM45AIR.45SS**



Cutting plate for aluminum. Angle 45°. (Sold per 10 pieces)

**BM45AIR.45ALU**



Screw for BM45AIR cutting plate. Sold per piece.

**BM45AIR.0009**



**Magnetic digital level box**  
 For measuring angles up to 90°

**MLB.90**

# EDG.600 Electric die grinder



Watch our machines in action on:  
[www.youtube.com/euroboorby](http://www.youtube.com/euroboorby)



## Technical data

Weight	1.8 kg
Motor power	600 W
Speed (no load)	12,000 - 27,000 rpm
Collet	6 mm
Voltage	110 - 120 V / 60 Hz
	220 - 240 V / 50 - 60 Hz

## Benefits

- Lightweight, small and compact design for use in tight spaces
- Easy to hold and carry
- Ideal for finishing dies, press working, die casting and moulding work



## Features



Adjustable speed

## Available as

- Carton box

**EDG.600**

# ADG.2(A/S/E) Air die grinders



Watch our machines in action on:  
[www.youtube.com/euroboorby](http://www.youtube.com/euroboorby)



Technical data			
	ADG.2A	ADG.2S	ADG.2E
Weight	0.53 kg	0.67 kg	1.31 kg
Free speed	20,000 rpm		22,000 rpm
Collet	6 mm		
Air inlet (PT)	1/4"		
Air hose (ID)	3/8"		
Avg. air consumption	0.113 m <sup>3</sup> /min (4 SCFM)	0.142 m <sup>3</sup> /min (5 SCFM)	
Working pressure	6.3 bar (90 psi)		
Length	193 mm	338 mm	
Height	70 mm	70 mm	

## Benefits

- Excellent for grinding, polishing, deburring and smoothing sharp edges
- Four-speed rear regulator
- 360 degrees adjustable exhaust deflector
- Safety lever trigger



ADG.2E



ADG.2A



ADG.2S

## Features



Adjustable speed



Working pressure  
6.3 bar  
(90 PSI)

## Available as

- Carton box
- Standard 6 mm (1/4") collet
- Optional 3 mm (1/8") collet

ADG.2A / ADG.2S / ADG.2E

# Carbide Rotary Burrs

Euroboor carbide rotary burrs are available in different cuts, models and sizes. Your choice depends on which material you have to work on and what finish you need.

Our burrs have an universal shank, but are best used combined with one of the Euroboor grinding machines.

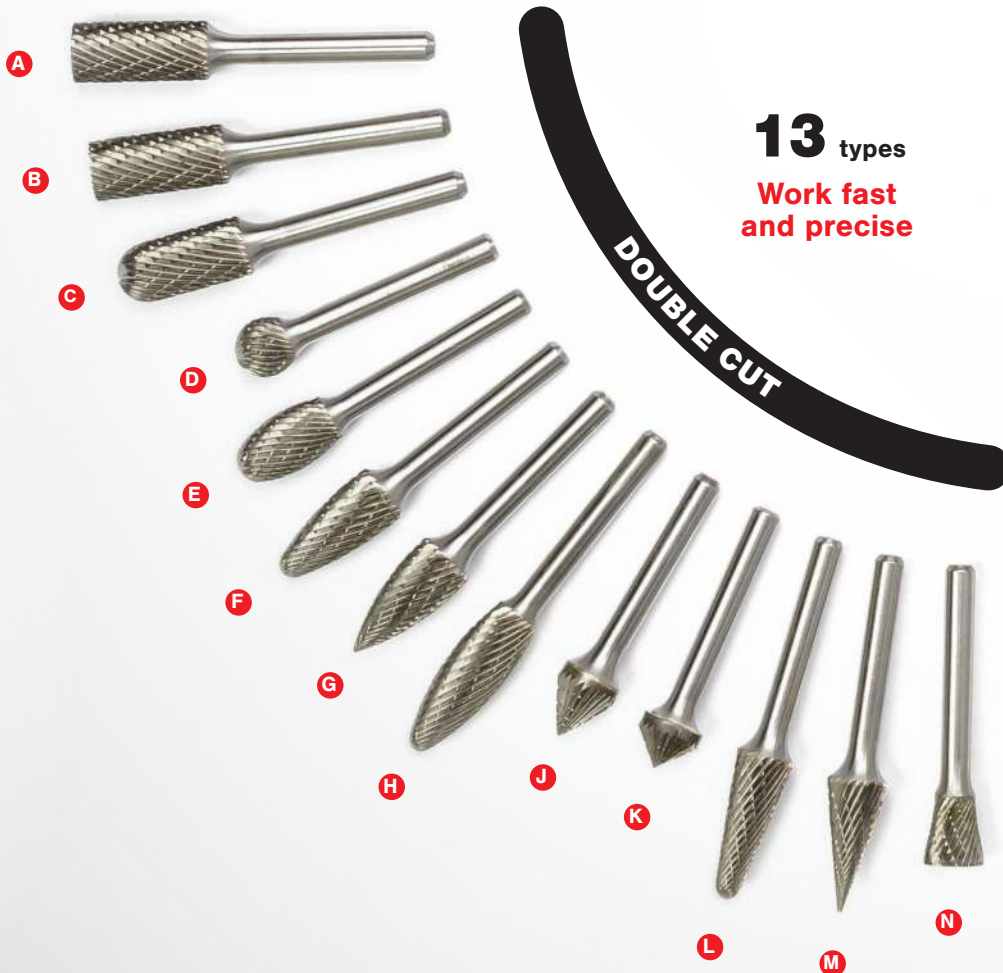
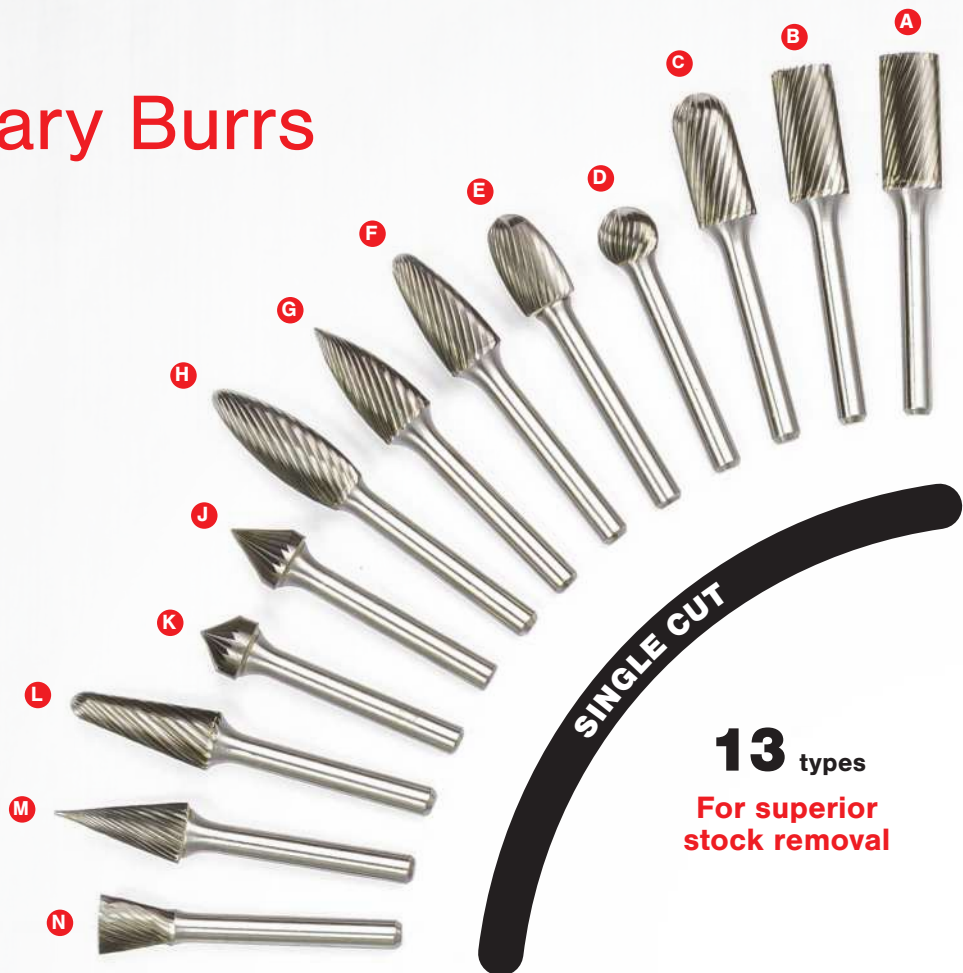

## Use with:

Euroboor die grinders EDG.600, ADG.2A, ADG.2S, ADG2E or other powerful die grinders

## Applications:

- Cutting out holes
- Deburring
- Leveling
- Milling out
- Surfacing
- Smoothing welds
- Shaping

## Also suitable for:

- Robot
- Flexible and straight shaft drive
- CNC machines



**DIAMOND CUT**

**11** types  
Create smooth finishes

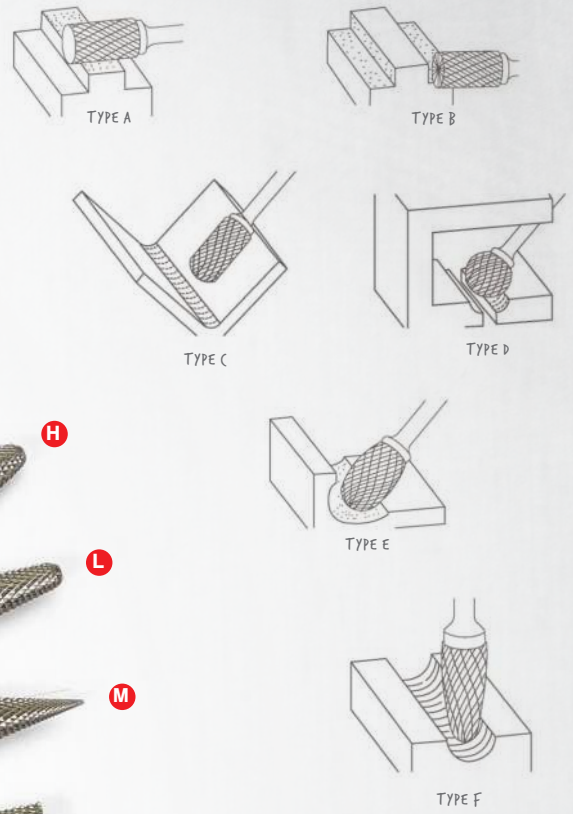

**ALU CUT**

**10** types  
Use on non-ferrous materials

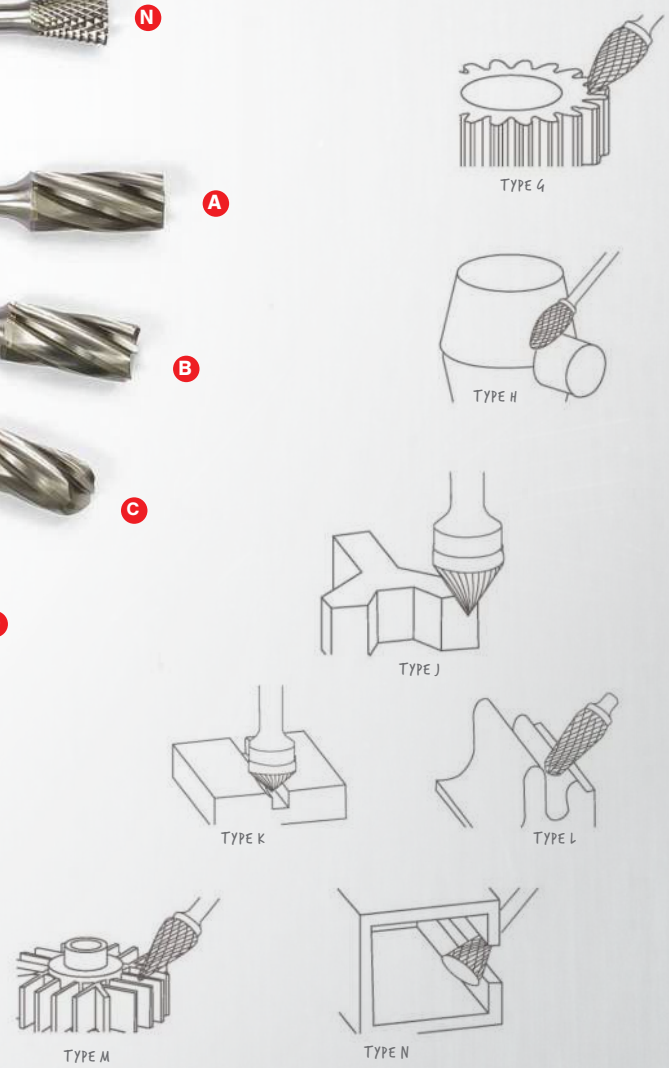

# Carbide Rotary Burrs specification

	Cast iron	Cast steel	Unhardened steels	Hardened steels	Low alloy steels	High alloy steels	Heat treated steels	Stainless steel	Titanium alloy	Brass	Bronze / Copper	Plastics	Aluminium	Zinc alloy
Single cut	•	•	•		•			•		•	•			
Double cut	•	•	•		•			•		•	•			
Diamond cut	•	•	•	•	•	•	•	•	•	•	•			
Alu cut												•	•	•

## Type A

Without end cut

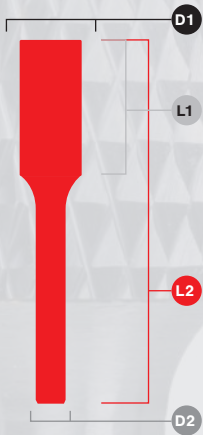

### Single cut

D1	D2	L1	L2	Code
3	3	13	38.5	RBS.A0303
6	6	16	61	RBS.A0606
8	6	20	65	RBS.A0806
10	6	20	55	RBS.A1006
12	6	25	70	RBS.A1206
16	6	25	70	RBS.A1606

### Double cut

D1	D2	L1	L2	Code
3	3	13	38.5	RB.A0303
6	6	16	61	RB.A0606
8	6	20	65	RB.A0806
10	6	20	65	RB.A1006
10	6	20	185	RBDL.A1006
12	6	25	70	RB.A1206
12	6	25	175	RBDL.A1206
16	6	25	70	RB.A1606

### Diamond cut

D1	D2	L1	L2	Code
8	6	20	65	RBD.A0806
10	6	20	65	RBD.A1006
12	6	25	70	RBD.A1206
16	6	25	70	RBD.A1606

### Alu cut

D1	D2	L1	L2	Code
6	6	16	61	RBA.A0606
10	6	20	65	RBA.A1006
12	6	25	70	RBA.A1206
16	6	25	70	RBA.A1606

## Type B

With end cut

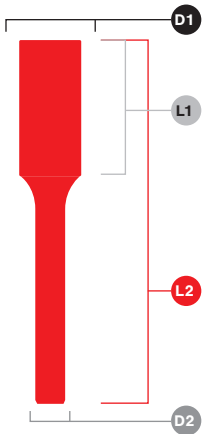

### Single cut

D1	D2	L1	L2	Code
3	3	16	38.5	RBS.B0303
6	6	13	61	RBS.B0606
8	6	20	65	RBS.B0806
10	6	20	65	RBS.B1006
12	6	25	70	RBS.B1206
16	6	25	70	RBS.B1606

### Double cut

D1	D2	L1	L2	Code
3	3	16	38.5	RB.B0303
6	6	13	61	RB.B0606
8	6	20	65	RB.B0806
10	6	20	65	RB.B1006
10	6	20	170	RBDL.B1006
12	6	25	70	RB.B1206
12	6	25	175	RBDL.B1206
16	6	25	70	RB.B1606

### Diamond cut

D1	D2	L1	L2	Code
8	6	20	65	RBD.B0806
10	6	20	65	RBD.B1006
12	6	25	70	RBD.B1206
16	6	25	70	RBD.B1606

### Alu cut

D1	D2	L1	L2	Code
6	6	13	61	RBA.B0606
10	6	20	65	RBA.B1006
12	6	25	70	RBA.B1206

## Type C

Ball nose cylinder

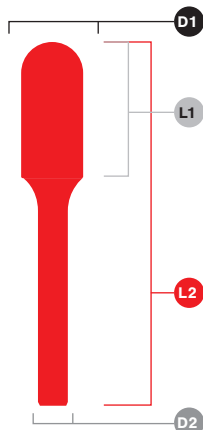

### Single cut

D1	D2	L1	L2	Code
3	3	13	38.5	RBS.C0303
6	6	16	61	RBS.C0606
8	6	20	65	RBS.C0806
9,5	6	20	65	RBS.C1006
12	6	25	70	RBS.C1206
16	6	25	70	RBS.C1606

### Diamond cut

D1	D2	L1	L2	Code
8	6	20	65	RBD.C0806
9,5	6	20	65	RBD.C1006
12	6	25	70	RBD.C1206
16	6	25	70	RBD.C1606

### Double cut

D1	D2	L1	L2	Code
3	3	13	38.5	RB.C0303
6	6	16	61	RB.C0606
8	6	20	65	RB.C0806
10	6	20	65	RB.C1006
10	6	20	170	RBDL.C1006
12	6	25	70	RB.C1206
12	8	25	70	RB.C1208
12	6	25	175	RBDL.C1206
16	6	25	70	RB.C1606

### Alu cut

D1	D2	L1	L2	Code
6	6	16	61	RBA.C0606
10	6	20	65	RBA.C1006
12	6	25	70	RBA.C1206
16	6	25	70	RBA.C1606

## Type D

Ball

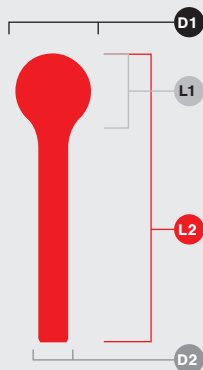

### Single cut

D1	D2	L1	L2	Code
3	3	2.7	38.5	RBS.D0303
6	6	5.4	50	RBS.D0606
8	6	7.2	52	RBS.D0806
10	6	9	54	RBS.D1006
12	6	10.8	55	RBS.D1206
16	6	14.4	59	RBS.D1606

### Diamond cut

D1	D2	L1	L2	Code
8	6	7.2	52	RBD.D0806
10	6	9	54	RBD.D1006
12	6	10.8	55	RBD.D1206
16	6	14.4	59	RBD.D1606

### Double cut

D1	D2	L1	L2	Code
3	3	2.7	38.5	RB.D0303
6	6	5.4	50	RB.D0606
8	6	7.2	52	RB.D0806
10	6	9	54	RB.D1006
10	6	9	159	RBDL.D1006
12	6	10.8	55	RB.D1206
12	6	10.8	161	RBDL.D1206
16	6	14.4	59	RB.D1606

### Alu cut

D1	D2	L1	L2	Code
6	6	5.4	50	RBA.D0606
10	6	9	54	RBA.D1006
12	6	10.8	55	RBA.D1206
16	6	14.4	59	RBA.D1606

## Type E

Oval

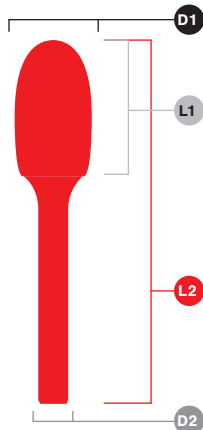

### Single cut

D1	D2	L1	L2	Code
3	3	7	38.5	RBS.E0303
6	6	10	55	RBS.E0606
8	6	13	58	RBS.E0806
10	6	16	61	RBS.E1006
12	6	20	65	RBS.E1206
16	6	25	75	RBS.E1606

### Diamond cut

D1	D2	L1	L2	Code
8	6	13	58	RBD.E0806
10	6	16	61	RBD.E1006
12	6	20	65	RBD.E1206
16	6	25	70	RBD.E1606

### Double cut

D1	D2	L1	L2	Code
3	3	7	38.5	RB.E0303
6	6	10	55	RB.E0606
8	6	13	58	RB.E0806
10	6	16	61	RB.E1006
10	6	16	166	RBDL.E1006
12	6	20	65	RB.E1206
12	6	20	170	RBDL.E1206
16	6	25	70	RB.E1606

### Alu cut

D1	D2	L1	L2	Code
6	6	10	55	RBA.E0606
10	6	16	61	RBA.E1006
12	6	20	65	RBA.E1206

## Type F

Ball nose tree

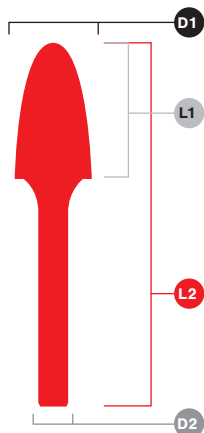

### Single cut

D1	D2	L1	L2	Code
3	3	13	38.5	RBS.F0303
6	6	18	63	RBS.F0606
8	6	20	65	RBS.F0806
10	6	20	65	RBS.F1006
12	6	25	70	RBS.F1206
16	6	25	70	RBS.F1606

### Double cut

D1	D2	L1	L2	Code
3	3	13	38.5	RB.F0303
6	6	18	63	RB.F0606
8	6	20	65	RB.F0806
10	6	20	65	RB.F1006
10	6	20	175	RBDL.F1006
12	6	25	70	RB.F1206
12	8	25	70	RB.F1208
12	6	25	175	RBDL.F1206
16	6	25	70	RB.F1606

### Diamond cut

D1	D2	L1	L2	Code
8	6	20	65	RBD.F0806
10	6	20	65	RBD.F1006
12	6	25	70	RBD.F1206
16	6	25	70	RBD.F1606

### Alu cut

D1	D2	L1	L2	Code
6	6	18	63	RBA.F0606
10	6	20	65	RBA.F1006
12	6	25	70	RBA.F1206
16	6	25	70	RBA.F1606

## Type G

Arc pointed tree

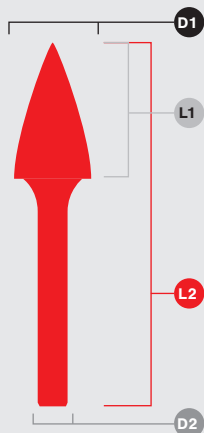

### Single cut

D1	D2	L1	L2	Code
3	3	13	38.5	RBS.G0303
6	6	18	63	RBS.G0606
8	6	20	65	RBS.G0806
10	6	20	65	RBS.G1006
12	6	25	70	RBS.G1206
16	6	25	70	RBS.G1606

### Double cut

D1	D2	L1	L2	Code
3	3	13	38.5	RB.G0303
6	6	18	63	RB.G0606
8	6	20	65	RB.G0806
10	6	20	65	RB.G1006
10	6	20	170	RBDL.G1006
12	6	25	70	RB.G1206
12	6	25	170	RBDL.G1206
16	6	25	70	RB.G1606

### Diamond cut

D1	D2	L1	L2	Code
8	6	20	65	RBD.G0806
9,5	6	20	65	RBD.G1006
12	6	25	70	RBD.G1206
16	6	25	70	RBD.G1606

### Alu cut

D1	D2	L1	L2	Code
6	6	18	63	RBA.G0606
10	6	20	65	RBA.G1006
12	6	25	70	RBA.G1206
16	6	25	70	RBA.G1606

## Type H

Flame

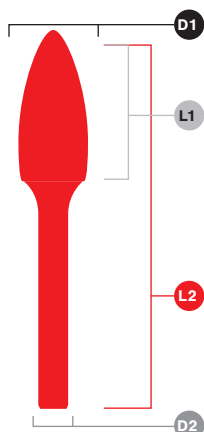

### Single cut

D1	D2	L1	L2	Code
3	3	13	38.5	RBS.H0303
6	6	18	63	RBS.H0606
8	6	20	65	RBS.H0806
10	6	20	65	RBS.H1006
12	6	25	70	RBS.H1206
16	6	36	81	RBS.H1606

### Double cut

D1	D2	L1	L2	Code
3	3	13	38.5	RB.H0303
6	6	18	63	RB.H0606
8	6	20	65	RB.H0806
10	6	20	70	RB.H1006
12	6	25	77	RB.H1206
12	6	25	202	RBDL.H1206
16	6	25	81	RB.H1606

### Diamond cut

D1	D2	L1	L2	Code
8	6	20	65	RBD.H0806
10	6	25	70	RBD.H1006
12	6	32	77	RBD.H1206
16	6	36	81	RBD.H1606

### Alu cut

D1	D2	L1	L2	Code
6	6	18	63	RBA.H0606
10	6	25	70	RBA.H1006
12	6	32	77	RBA.H1206
16	6	36	81	RBA.H1606

## Type J

60 degree cone

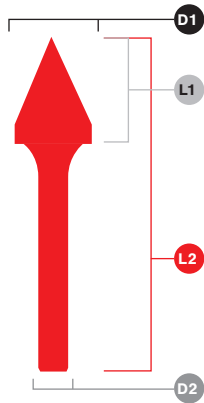

### Single cut

D1	D2	L1	L2	Code
6	6	5.2	50	RBS.J0606
10	6	8.7	53	RBS.J1006
12	6	10.4	55	RBS.J1206
16	6	13.8	58	RBS.J1606

### Double cut

D1	D2	L1	L2	Code
6	6	5.2	50	RB.J0606
10	6	8.7	53	RB.J1006
12	6	10.4	55	RB.J1206
16	6	13.8	58	RB.J1606

### Diamond cut

D1	D2	L1	L2	Code
10	6	8.7	53	RBD.J1006
12	6	10.4	55	RBD.J1206
16	6	13.8	58	RBD.J1606

## Type K

90 degree cone

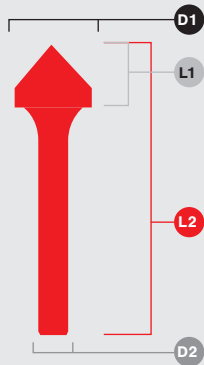

### Single cut

D1	D2	L1	L2	Code
6	6	3	48	RBS.K0606
10	6	5	50	RBS.K1006
12	6	6	51	RBS.K1206
16	6	8	53	RBS.K1606

### Double cut

D1	D2	L1	L2	Code
6	6	3	48	RB.K0606
10	6	5	50	RB.K1006
12	6	6	51	RB.K1206
16	6	8	53	RB.K1606

### Diamond cut

D1	D2	L1	L2	Code
10	6	5	50	RBD.K1006
12	6	28	73	RBD.K1206
16	6	33	78	RBD.K1606

## Type L

Ball nose cone

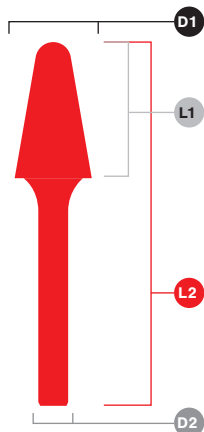

### Single cut

D1	D2	L1	L2	Code
3	3	13	38.5	RBS.L0303
6	6	16	61	RBS.L0606
8	6	22	67	RBS.L0806
10	6	25	70	RBS.L1006
12	6	28	73	RBS.L1206
16	6	33	78	RBS.L1606

### Double cut

D1	D2	L1	L2	Code
3	3	13	38.5	RB.L0303
6	6	18	61	RB.L0606
8	6	22	67	RB.L0806
10	6	25	70	RB.L1006
10	6	25	175	RBDL.L1006
12	6	28	73	RB.L1206
12	6	28	178	RBDL.L1206
16	6	33	78	RB.L1606

### Diamond cut

D1	D2	L1	L2	Code
8	6	22	67	RBD.L0806
10	6	25	70	RBD.L1006
12	6	28	73	RBD.L1206
16	6	33	78	RBD.L1606

### Alu cut

D1	D2	L1	L2	Code
6	6	16	61	RBA.L0606
10	6	25	70	RBA.L1006
12	6	28	73	RBA.L1206

## Type M

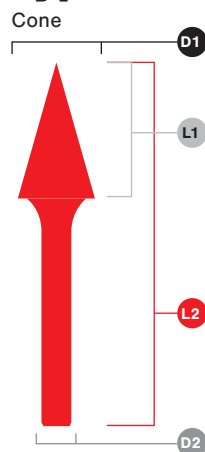

### Single cut

D1	D2	L1	L2	Code
3	3	13	38.5	RBS.M0303
6	6	18	63	RBS.M0606
8	6	20	65	RBS.M0806
10	6	20	65	RBS.M1006
12	6	25	70	RBS.M1206
16	6	25	70	RBS.M1606

### Diamond cut

D1	D2	L1	L2	Code
8	6	20	65	RBD.M0806
10	6	20	65	RBD.M1006
12	6	25	70	RBD.M1206
16	6	25	70	RBD.M1606

### Double cut

D1	D2	L1	L2	Code
3	3	13	38.5	RB.M0303
6	6	18	63	RB.M0606
8	6	20	65	RB.M0806
10	6	20	65	RB.M1006
12	6	25	70	RB.M1206
16	6	25	70	RB.M1606

### Alu cut

D1	D2	L1	L2	Code
6	6	18	63	RBA.M0606
10	6	20	65	RBA.M1006
12	6	25	70	RBA.M1206

## Type N

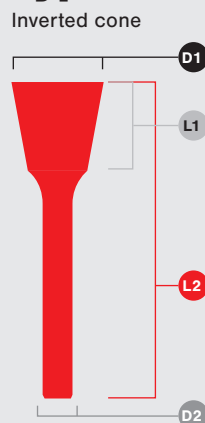

### Single cut

D1	D2	L1	L2	Code
3	3	13	38.5	RBS.N0303
6	6	7	52	RBS.N0606
10	6	10	55	RBS.N1006
12	6	13	58	RBS.N1206
16	6	16	61	RBS.N1606

### Diamond cut

D1	D2	L1	L2	Code
10	6	10	55	RBD.N1006
12	6	13	58	RBD.N1206
16	6	16	61	RBD.N1606

### Double cut

D1	D2	L1	L2	Code
3	3	13	38.5	RB.N0303
6	6	17	52	RB.N0606
10	6	10	55	RB.N1006
12	6	13	58	RB.N1206
16	6	16	61	RB.N1606

# Applications

#### Single cut carbide burr



Single cut provides superior stock removal with long chips, and good surface finishes.

#### Double cut carbide burr



Double cut burrs allows rapid stock removal. The finer tothing surface provides high stock removal with fine and short chips for high control and great surface finish.

#### Diamond cut carbide burr



This uniquely developed burr shape enhances the capacity of control and smooth processing on harder steel types. The extra fine tothing creates the best surface finish with extremely small chips, and high stock removal.

#### Alu cut carbide burr



They are especially designed to have a high stock removal on non-ferrous materials.

**Samurai precision**

Advanced Japanese heat treatment technology is applied on the Euroboor rotary burrs, improving the strength of the steel, creating sharper edges on the burr and give wear resistance.

**More stock removal, less time**

Thanks to the design and the characteristics of tungsten carbide, Euroboor rotary burrs provide high stock removal. This saves a lot of time and energy.

# Carbide Rotary Burrs

**Long Lasting**

Due to the innovative surface treatment and the choice of materials, the Euroboor rotary burrs are long lasting and therefore perfect for usage over a longer period of time.

**Long lasting**

The improved welding technology on the shank is making the burrs very strong and capable of handling high forces and high temperatures without breaking.

**High durability – Less waste**

All of our research, innovations and applied technologies brings you high quality rotary burrs that are suited for the toughest of jobs, without breaking or losing performance. This means no more waste of burrs and money. That makes Euroboor burrs the best choice for you!

**Conical shaped shank**

The advanced conical shape of the shank divides the pressure over a larger area, making the burr even less likely to break under high forces.

# EDC.355 Dry cut-off saw



Watch our machines in action on:  
[www.youtube.com/euroboorby](http://www.youtube.com/euroboorby)



### Technical data

Dimensions (l x w x h)	620 x 350 x 630 mm	
Weight	18.6 kg	
Motor power	2,480 W	
Cutting speed (no load)	1,450 rpm	
Cutting angle	adjustable, 0° - 45°	
Bore size	Ø 25.4 mm (1")	
Cutting capacity at 0°	●	120 mm
	■	105 mm
	■	90 x 145 mm
Cutting capacity at 45°	●	90 mm
	■	80 mm
	■	90 x 80 mm
Max. Ø saw blade	355 mm	
Voltage	110 - 120 V / 60 Hz	
	220 - 240 V / 50 - 60 Hz	

### Benefits

- Adjustable sawing angle from 0° to 45°
- Molded aluminum base with adjustable angle indication.
- 3 attachment points to fix the machine to your workbench.
- Ergonomic handle and locking pin to easily carry the machine
- Safety button for protection against accidental start-up.
- Transparent protective shield for safely discharging of the chips
- Robust clamp for very precise clamping of materials
- Dust collection tray for a cleaner workspace
- Built-in soft-start functionality



Mounting holes



Easy blade replacement



Dust collection tray



Adjustable vice 0° - 45°

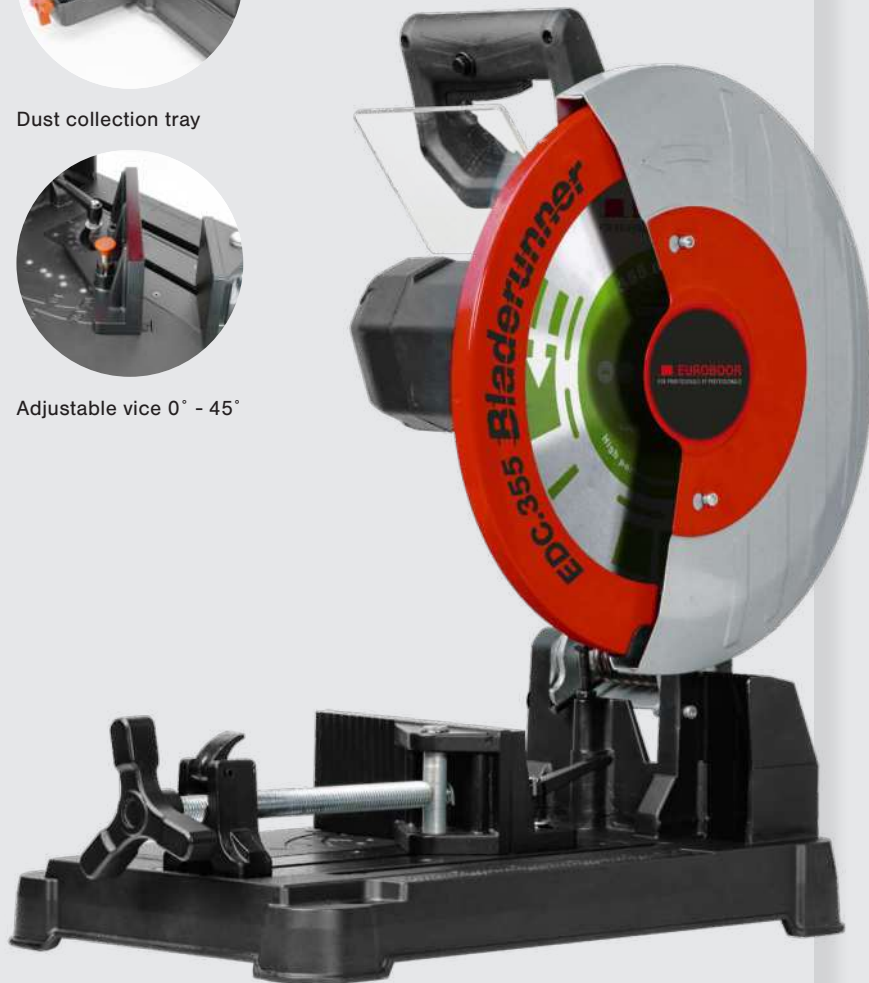

### Features



**Cutting capacity**  
120 mm



**Adjustment angle**  
0 - 45°

### Sawblades 355 mm



saw blade 355 mm, 66 teeth, bore 25.4 mm

**Art. nr.:**  
130.355/66



saw blade 355 mm, 66 teeth, for mild steel, bore 25.4 mm

**Art. nr.:**  
130.355/66/M



saw blade 355 mm, 80 teeth, bore 25.4 mm

**Art. nr.:**  
130.355/80



# EDC.355/36V

Battery powered  
Dry cut-off saw



Battery operated



Mounting holes



Dust collection tray



Adjustable vice 0° - 45°



Watch our machines in action on:  
[www.youtube.com/euroboorby](http://www.youtube.com/euroboorby)



### Technical data

Dimensions (l x w x h)	540 x 350 x 600 mm	
Weight	21 kg	
Motor power	3,000 W	
Cutting speed (no load)	1,200 rpm	
Cutting angle	adjustable, 0° - 45°	
Bore size	Ø 25.4 mm (1")	
Cutting capacity at 0°	●	120 mm
	■	105 mm
	■	90 x 145 mm
Cutting capacity at 45°	●	95 mm
	■	80 mm
	■	90 x 80 mm
Max. Ø saw blade	355 mm	
Voltage	18 V 9 Ah Li-ion (x2)	

### Benefits

- Battery-powered motor system
- Adjustable sawing angle from 0° to 45°
- Molded aluminum base with adjustable angle indication.
- 3 attachment points to fix the machine to your workbench.
- Ergonomic handle and locking pin to easily carry the machine
- Safety button for protection against accidental start-up.
- Transparent protective shield for safely discharging of the chips
- Robust clamp for very precise clamping of materials
- Dust collection tray for a cleaner workspace
- Built-in soft-start functionality
- Brushless technology

### Features



Battery operated



Makita LXT 18V platform



Brushless motor



Cutting capacity 120 mm



Adjustment angle 0 - 45°

### Sawblades 355 mm



saw blade 355 mm, 66 teeth, bore 25.4 mm

Art. nr.: 130.355/66



saw blade 355 mm, 66 teeth, for mild steel, bore 25.4 mm

Art. nr.: 130.355/66/M



saw blade 355 mm, 80 teeth, bore 25.4 mm

Art. nr.: 130.355/80

### Accessories



Battery 9Ah 18V

EB9A



Charger

EBC1

(Batteries are not included as standard)

# EBS.500 Band saw



Simple speed adjustment with quick guide



Wide cutting angle adjustment range



Watch our machines in action on:  
[www.youtube.com/euroboorby](http://www.youtube.com/euroboorby)



## Technical data

Dimensions (l x w x h)	650 x 310 x 450 mm	
Weight	20 kg	
Motor power	1,010 W	
Cutting speed	adjustable, 30 - 80 m	
Cutting angle	adjustable, 0° - 60°	
Cutting capacity: at 0°	● / ■	125 mm
	■	130 x 125 mm
	● / ■	76 mm
at 45°	● / ■	76 mm
at 60°	● / ■	50 mm
Saw band	13 x 0.65 x 1,440 mm, 10 - 14 tpi M42 8% Cobalt	
Voltage	110 - 120 V / 60 Hz	
	220 - 240 V / 50 - 60 Hz	

## Benefits

- Adjustable vice, cutting angle and sawing speed
- Constant speed due to digital electronic speed regulator
- Wide cutting angle adjustment range
- Double motor protection: amperage and temperature limiter
- Anti-reset safety function
- User-friendly vice with clear indicators
- Adjustable bar stop rod for mass produced cuts
- Chip scraper



## Features



Adjustable speed



Cutting capacity  
125 mm



Adjustment angle  
0 - 60°

## Bandsaw



Saw band 13 x 0.65 x 1,440 mm, 6 - 10 tpi (set of 5)

Art. nr.: 500.0001

# Lifting magnets





**EUROBOOR**  
FOR PROFESSIONALS BY PROFESSIONALS

**ELM.1000**

# Lifting magnets



Watch our machines in action on:  
[www.youtube.com/euroboorby](http://www.youtube.com/euroboorby)



Euroboor lifting magnets are engineered with top priority on safety and practical use. This attention to detail during the manufacturing process makes it possible to combine high-uniform magnetic strength with easy and smooth handle operation. The compact design and limited weight make the magnets easy to handle, optimize workspace and fully exploit crane capacity.

### Safety factor 3.5

Euroboor lifting tools are designed to withstand at least 3.5 times the recommended workload and each lifting magnet is individually tested and delivered with a specific certificate as proof of safety. Our lifting tools provide reliable and consistent performance, also under extreme conditions.

### Benefits:

- **Safety factor 3.5; Lift at least 3.5 times the suggested weight load**
- **Suitable for flat and tubular objects**
- **Suitable for rough or finished surfaces**
- **High lifting capacity**
- **Suitable for temperatures up to 80°C / 176 °F**
- **Maintenance free**
- **Certified safety**
- **Reliable and consistent performance, also under extreme conditions**
- **Easy handling and operation**

Model	ELM.125	ELM.250	ELM.500	ELM.1000	ELM.2000
Length (mm)	175	213	288	336	559
Width (mm)	76	82	112	148	154
Height (mm)	134	160	195	234	295
Width of eye (mm)	30	40	42	52	52
Weight (kg)	6.5	9.4	21,2	43	95.2
Workload limit (kg) flat material	125	250	500	1,000	2,000
Workload limit (kg) round material	60	125	250	500	1,000
Plate minimal thickness (mm)	15	25	30	40	55
Round min - max thickness (Ø)	40 / 80	50 / 100	100 / 250	150 / 380	180 / 450
Max. operation temp. (°C)	< 80°	< 80°	< 80°	< 80°	< 80°





Lifting magnet 125 kg  
**ELM.125**



Lifting magnet 250 kg  
**ELM.250**



Lifting magnet 500 kg  
**ELM.500**



Lifting magnet 1,000 kg  
**ELM.1000**



Lifting magnet 2,000 kg  
**ELM.2000**

The design and appearance of some components may change due to constantly ongoing development and improvement.



### World wide

Euroboor is currently serving an increasing amount of more than 70 countries, covering all continents. With multiple offices throughout the world and many committed distributors. We are proud to be a close-knit team of international employees with shared values and ambitions, ready to make your working day an easier day.



### Stock

Euroboor is a privately owned company with in-house production and continuous supply to each of our offices. Whatever your needs are, we strive to serve you with the best possible solutions on the shortest term possible.



### Fast delivery

With a fine network of stock keeping offices, distributors and wholesalers, Euroboor will make sure your orders are being supplied with the speed and care they deserve.



### Tech support

Our qualified staff of specialists can help you with all your technical requests. Whether it comes down to our offerings, servicing your tool or advise on the most difficult drilling tasks, there is hardly anything we have not dealt with before.



### Premium parts

Our complete product range is built on proper quality standards. Throughout the lifecycle of your tools, we will make sure these standards are being kept with supplying you only original manufacturing spare parts.

# Metal workers choice



**Our company logo represents the slug created with the use of our annular cutters – the solid Euroboor core of your metal working job.**

# Euroboor worldwide



The Netherlands



Brasil



China



United States of America



United Arab Emirates



[www.euroboor.com](http://www.euroboor.com)

#### The Netherlands office

Kryptonstraat 110  
2718 TD Zoetermeer  
t +31(0)79 361 49 90  
e [info.nl@euroboor.com](mailto:info.nl@euroboor.com)



#### Brasil office

Rua Harpia 438 Novo Horizonte, Serra, 29.163-308  
Espírito Santo, Brasil  
t +55 27 98827 1043  
e [contato.br@euroboor.com](mailto:contato.br@euroboor.com)

#### UAE office

SAIF Zone A2-084  
P.O. Box No: 120085, Sharjah  
t +971 655 784 54  
e [info.uae@euroboor.com](mailto:info.uae@euroboor.com)

#### USA office

160 White Oak Road  
Hayden, AL 35079  
t +1 844 266 85 27  
e [info.usa@euroboor.com](mailto:info.usa@euroboor.com)

#### China office

2nd Floor, HongJi Building. No9#, LiuShi Road,  
LiXiang Village, Tangshi  
Yangshe Town, ZhangJiagang City,  
Jiangsu China 215600  
t +8651258549182  
e [info@euroboorchina.com](mailto:info@euroboorchina.com)

[www.euroboor.com](http://www.euroboor.com)

# EUROBOOR

FOR PROFESSIONALS BY PROFESSIONALS

